

# ***Vintage Pro***

## ***128-Voice Classic Synth/Keys Module***

### **Vintage Pro**

#### ***Owners Manual***

© 2002 E-MU Systems, Inc.

All Rights Reserved

**FI 12482 Rev. B**

#### **E-MU World Headquarters**

##### **E-MU Systems, Inc. U.S.A.**

1600 Green Hills Road

Scotts Valley, CA USA

95066

Telephone: 831-438-1921

Fax: 831-438-8612

Internet: [www.emu.com](http://www.emu.com)

#### **Europe, Africa, Middle East**

##### **E-MU Systems, Ltd.**

Suite 6, Adam Ferguson House

Eskmills Industrial Park

Musselburgh, East Lothian

Scotland, EH21 7PQ

Tel: +44 (0) 131-653-6556

Fax: +44 (0) 131-665-0473

#### **Important Notice:**

In order to obtain warranty service on your Vintage Pro unit, the serial number sticker must be intact and you must have a sales receipt or other proof of purchase. If there is no serial number sticker on the Vintage Pro, please contact E-MU Systems at once.

This product is covered under one or more of the following U.S. patents: 4,404,529; 4,506,579; 4,699,038; 4,987,600; 5,013,105; 5,072,645; 5,111,727; 5,144,676; 5,170,367; 5,248,845; 5,303,309; 5,317,104; 5,342,990; 5,430,244 and foreign patents and/or pending patents. Vintage Pro is a registered trademarks of E-MU Systems, Inc. All other trademarks belong to their respective companies.

# *Table of Contents*

|  |           |
|--|-----------|
| <b>Introduction .....</b>                      | <b>1</b>  |
| Product Description .....                      | 1         |
| Overview .....                                 | 3         |
| <b>Important Safety Instructions .....</b>     | <b>4</b>  |
| <b>Wichtige Sicherheitsvorschriften .....</b>  | <b>7</b>  |
| <b>Consignes de sécurité importantes .....</b> | <b>10</b> |
| <b>Setup .....</b>                             | <b>13</b> |
| Unpacking .....                                | 13        |
| Connection Instructions .....                  | 14        |
| Basic Setup .....                              | 14        |
| Studio Setup .....                             | 15        |
| Performance Setup .....                        | 16        |
| Power Up! .....                                | 17        |
| Instant Gratification .....                    | 18        |
| Playing Demo Sequences .....                   | 18        |
| Auditioning Presets & Beats .....              | 18        |
| Selecting and Quick Editing Presets .....      | 19        |
| <b>Basic Operations .....</b>                  | <b>21</b> |
| Front Panel .....                              | 21        |
| Volume Control .....                           | 21        |
| Master Button .....                            | 21        |
| Edit Button .....                              | 21        |
| Control Button .....                           | 21        |
| Audition Button .....                          | 22        |
| Left/Right Cursor Buttons .....                | 22        |
| Arps/Beats Button .....                        | 22        |
| Save/Copy Button .....                         | 22        |
| Home/Enter Button .....                        | 23        |
| Data Entry Control .....                       | 23        |
| Controller Knobs .....                         | 23        |

|                                   |           |
|-----------------------------------|-----------|
| Front Panel Controller Modes..... | 23        |
| Real-time Control .....           | 23        |
| Quick Edit .....                  | 24        |
| Deep Edit Mode .....              | 25        |
| Main Screen .....                 | 26        |
| MIDI Channel Selection .....      | 26        |
| Preset Selection .....            | 26        |
| Channel Volume .....              | 27        |
| Channel Pan .....                 | 27        |
| Channel Arpeggiator .....         | 28        |
| Sound Navigator.....              | 29        |
| Preset Category .....             | 29        |
| Instrument Category .....         | 29        |
| Multitimbral Operation .....      | 30        |
| <b>Arp/Beats Menu .....</b>       | <b>31</b> |
| Base Tempo .....                  | 33        |
| Beats.....                        | 34        |
| Beats Mode .....                  | 36        |
| Status .....                      | 36        |
| Beats Channel .....               | 36        |
| Trigger Channel .....             | 36        |
| Beats Controllers .....           | 38        |
| Beat Velocity Group 1-4 .....     | 38        |
| Beat Xpose Group 1-4 .....        | 38        |
| Beat Busy .....                   | 39        |
| Beat Variation .....              | 40        |
| Beats Keys Layout .....           | 40        |
| 1-Bar Trigger Option .....        | 40        |
| Beats Keys Offset .....           | 41        |
| Beats Part Velocity .....         | 42        |
| Beats Part Transpose .....        | 43        |
| Beats Part Group .....            | 44        |
| Master Riff .....                 | 44        |
| Riff Tempo .....                  | 45        |
| Riff Controllers .....            | 45        |
| MIDI Song Start .....             | 46        |
| Arp/Riff MIDI Out .....           | 46        |
| Arpeggiators .....                | 47        |
| Arp Controllers .....             | 48        |
| Arpeggiator Resolution.....       | 48        |
| Arpeggiator Extension .....       | 48        |
| Arpeggiator Velocity .....        | 48        |
| Arpeggiator Gate .....            | 48        |
| Arpeggiator Interval .....        | 48        |

|   |           |
|---|-----------|
| Master Arpeggiator Parameters .....               | 48        |
| Status .....                                      | 49        |
| Mode .....  | 49        |
| Note Value .....                                  | 50        |
| Arpeggiator Pattern Speed .....                   | 50        |
| Pattern .....                                     | 50        |
| Velocity .....                                    | 51        |
| Gate Time .....                                   | 51        |
| Extension Count .....                             | 52        |
| Extension Interval .....                          | 52        |
| Sync .....  | 53        |
| Pre-Delay .....                                   | 53        |
| Duration .....                                    | 54        |
| Post-Delay .....                                  | 54        |
| Recycle .....                                     | 55        |
| Keyboard Thru .....                               | 55        |
| Latch .....                                       | 55        |
| Send MIDI System Exclusive Data .....             | 56        |
| Editing a User Arpeggiator Pattern .....          | 57        |
| Pattern Step Number .....                         | 57        |
| Key .....   | 57        |
| Key Offset .....                                  | 58        |
| Tie .....   | 58        |
| Rest .....  | 58        |
| Skip .....  | 58        |
| End .....   | 58        |
| Velocity .....                                    | 59        |
| Duration .....                                    | 59        |
| Repeat .....                                      | 59        |
| User Pattern Name .....                           | 60        |
| Multi-Channel Arpeggiating.....                   | 61        |
| Using a MIDI Interface to Channelize Data.....    | 62        |
| <b>Master Menu .....</b>                          | <b>63</b> |
| Defining Master Parameters .....                  | 64        |
| Transpose/Tune .....                              | 64        |
| Bend Range .....                                  | 64        |
| Velocity Curve .....                              | 65        |
| Mix Output .....                                  | 66        |
| Mix Screens .....                                 | 68        |
| Master Effects .....                              | 68        |
| Effects Mode .....                                | 68        |
| Effects Multi Mode Control .....                  | 69        |
| Master FXA Algorithm .....                        | 70        |
| A Effect Types .....                              | 70        |
| FXA Parameters: Decay/HF Damping FxB -> FxA ..... | 70        |

|  |           |
|--|-----------|
| FXA Send Amounts .....                             | 71        |
| Master FXB Algorithm .....                         | 71        |
| B Effect Types .....                               | 71        |
| FXB Parameters: Feedback/LFO Rate Delay Time ..... | 72        |
| FXB Send Amounts .....                             | 72        |
| <b>MIDI Parameters .....</b>                       | <b>73</b> |
| MIDI Mode .....                                    | 73        |
| MIDI SysEx ID .....                                | 73        |
| MIDI Enable .....                                  | 74        |
| MIDI Program Change -> Preset .....                | 74        |
| Receive Program Change .....                       | 75        |
| Real-time Controller Assignment .....              | 75        |
| MIDI Footswitch Assign .....                       | 76        |
| Tempo Controller .....                             | 77        |
| Knob Preset Quick-Edit .....                       | 77        |
| Knobs Deep Edit .....                              | 78        |
| Knobs/Riff MIDI Out .....                          | 78        |
| Preset Edit All Layers Enable .....                | 78        |
| Front Panel Knob Calibration .....                 | 79        |
| MIDI SysEx Packet Delay .....                      | 80        |
| Send MIDI System Exclusive Data .....              | 80        |
| User Key Tuning .....                              | 81        |
| Output Format .....                                | 82        |
| Screen Viewing Angle .....                         | 82        |
| <br>   |           |
| <b>Programming Basics .....</b>                    | <b>83</b> |
| Modulation .....                                   | 84        |
| Modulation Sources .....                           | 85        |
| Random Sources .....                               | 86        |
| Modulation PatchCords.....                         | 86        |
| Envelope Generators .....                          | 87        |
| Tempo-based Envelopes .....                        | 88        |
| Envelope Repeat .....                              | 88        |
| Low Frequency Oscillators (LFOs).....              | 89        |
| Clock Modulation.....                              | 90        |
| Modulation Destinations .....                      | 92        |
| Modulation Processors .....                        | 93        |
| Preset Modulation Processors .....                 | 95        |
| Using the Modulation Processors .....              | 97        |
| More Examples .....                                | 99        |
| Dynamic Filters .....                              | 101       |
| What is a Filter? .....                            | 102       |
| Parametric Filters .....                           | 105       |
| The Z-Plane Filter .....                           | 106       |

|   |            |
|---|------------|
| Signal Flow .....                             | 107        |
| MIDI Channels & Real-time Controls.....       | 108        |
| Bank Select Commands .....                    | 110        |
| Stereo Mix Outputs .....                      | 111        |
| <b>Edit Menu .....</b>                        | <b>113</b> |
| Preset Name .....                             | 114        |
| Four Layer Architecture .....                 | 115        |
| Selecting Layers .....                        | 115        |
| Defining Layer Parameters .....               | 116        |
| Selecting an Instrument .....                 | 116        |
| Sound Navigator .....                         | 116        |
| Defining Key Range .....                      | 117        |
| Defining the Velocity Crossfade Range .....   | 120        |
| Defining the Real-time Crossfade Range .....  | 122        |
| Transposing the Instrument .....              | 125        |
| Tuning .....                                  | 126        |
| Background: Transpose vs. Coarse Tuning ..... | 126        |
| Amplifier .....                               | 126        |
| Volume Envelope .....                         | 127        |
| Selecting the Mode .....                      | 127        |
| Defining the Volume Envelope .....            | 128        |
| Chorusing the Layer .....                     | 129        |
| Sound Start Offset and Delay .....            | 129        |
| Non-Transpose Mode .....                      | 130        |
| Solo Mode .....                               | 130        |
| Assign Group .....                            | 131        |
| Glide .....                                   | 132        |
| Z-Plane Filters .....                         | 132        |
| Filter Types .....                            | 133        |
| Vintage Pro Filter Types .....                | 136        |
| Filter Parameters .....                       | 136        |
| Filter Envelope .....                         | 136        |
| Envelope Repeat .....                         | 137        |
| Defining the Filter Envelope .....            | 138        |
| Auxiliary Envelope .....                      | 138        |
| Low Frequency Oscillators (LFOs) .....        | 138        |
| Shape .....                                   | 139        |
| Sync .....                                    | 140        |
| Rate .....                                    | 140        |
| Delay .....                                   | 141        |
| Variation .....                               | 142        |
| PatchCords .....                              | 143        |
| Modulator Polarity .....                      | 144        |
| Pitch Bend Range .....                        | 146        |
| Mix Output .....                              | 146        |

|  |            |
|--|------------|
| Common Preset Parameters .....             | 147        |
| Preset Effects .....                       | 147        |
| FXA Algorithm .....                        | 149        |
| A Effect Types .....                       | 149        |
| FXA Parameters .....                       | 150        |
| FXA Send Amounts .....                     | 150        |
| FXB Algorithm .....                        | 150        |
| B Effect Types .....                       | 150        |
| FXB Parameters .....                       | 151        |
| FXB Send Amounts .....                     | 151        |
| Preset PatchCords .....                    | 151        |
| Initial Controller Amount .....            | 153        |
| Keyboard Tuning .....                      | 154        |
| The Just C Tuning Tables .....             | 155        |
| Preset Links .....                         | 156        |
| Preset Tempo Offset .....                  | 157        |
| Audition Riff Selection .....              | 157        |
| Play Solo Layers .....                     | 157        |
| <b>Programming Tutorial .....</b>          | <b>159</b> |
| Editing Presets.....                       | 159        |
| Changing the Instrument .....              | 159        |
| Changing the Tuning of an Instrument ..... | 160        |
| Chorus .....                               | 161        |
| Volume Envelope .....                      | 161        |
| Working with Filters .....                 | 163        |
| Adding the Filter Envelope .....           | 164        |
| Changing Filter Types .....                | 166        |
| Envelope Repeat .....                      | 167        |
| Practice Modulating .....                  | 167        |
| Troubleshooting .....                      | 168        |
| Linking Presets .....                      | 169        |
| Using External Processing.....             | 170        |
| Multitimbral Sequencing.....               | 171        |
| <b>Effects .....</b>                       | <b>173</b> |
| Effects Overview.....                      | 173        |
| The Effects Sends .....                    | 173        |
| Effect Types.....                          | 175        |
| Effect Parameters .....                    | 175        |
| Decay .....                                | 176        |
| High Frequency Damping .....               | 176        |
| Feedback .....                             | 176        |
| LFO Rate .....                             | 176        |
| Delay .....                                | 176        |
| Effects Programmed in the Preset.....      | 177        |

|  |            |
|--|------------|
| Master Effects .....                                   | 178        |
| Effects Mode .....                                     | 180        |
| Flexible Effects Control .....                         | 180        |
| Using the Effects Channel Settings in Multi Mode ..... | 182        |
| Effect B Into Effect A .....                           | 182        |
| General Effect Descriptions .....                      | 184        |
| Reverb .....   | 184        |
| Chorus .....   | 185        |
| Doubling .....   | 185        |
| Slapback .....   | 185        |
| Stereo Flanger .....                                   | 185        |
| Delay .....  | 186        |
| Stereo Delay .....                                     | 186        |
| Panning Delay .....                                    | 186        |
| Dual Tap .....   | 186        |
| Vibrato .....  | 186        |
| Distortion .....                                       | 186        |
| <b>Save/Copy Menu .....</b>                            | <b>187</b> |
| Saving a Preset.....                                   | 187        |
| Copying Information .....                              | 188        |
| Copy Preset .....                                      | 188        |
| Copy Layer .....                                       | 188        |
| Copy PatchCords .....                                  | 189        |
| Copy Preset PatchCords .....                           | 190        |
| Copy Arpeggiator Settings .....                        | 190        |
| Copy Arpeggiator Pattern .....                         | 191        |
| Copy Preset Bank .....                                 | 191        |
| Multisetups.....                                       | 192        |
| Restoring Multisetups .....                            | 192        |
| Multisetup Name .....                                  | 193        |
| Saving Multisetups .....                               | 193        |
| Create Random Preset .....                             | 194        |
| Sound Authoring .....                                  | 195        |
| Rename Flash SIMM .....                                | 196        |
| Duplicate Flash .....                                  | 197        |
| <b>Appendix .....</b>                                  | <b>199</b> |
| Front Panel Knob Functions .....                       | 199        |
| Basic Preset Knob Functions .....                      | 199        |
| Beat Preset  |            |
| Knob Function .....                                    | 200        |
| Arp Preset   |            |
| Knob Function .....                                    | 200        |
| Presets .....  | 200        |
| Preset Categories .....                                | 200        |



|                                 |            |
|---------------------------------|------------|
| Preset Listing .....            | 201        |
| Instrument Listing .....        | 205        |
| Riff Listing .....              | 209        |
| Velocity Curves.....            | 211        |
| PatchCord Amount Chart.....     | 213        |
| E-MU Expansion Sound Sets.....  | 214        |
| Installing Sound SIMMs.....     | 216        |
| MIDI .....                      | 218        |
| Received Channel Commands ..... | 225        |
| Technical Specifications.....   | 226        |
| Warranty .....                  | 227        |
| <b>Index .....</b>              | <b>229</b> |



# Introduction

## Product Description

Congratulations on your purchase of the E-MU Vintage Pro. Vintage Pro offers you all of the legendary keyboard sounds of the '60's, '70's and '80's in one rack space. From tonewheel organs and suitcase keyboards to analog and FM synthesizers, Vintage Pro gives you the most authentic and comprehensive collection of classic keyboard sounds ever assembled.

The power of Vintage Pro begins with 128 voice polyphony. This means that 128 different instrument lines can be played at once! With all these voices, 16 MIDI channels didn't seem to be quite enough, so we added another MIDI input jack to allow 32 MIDI channel operation and the ability to access 128MB of sound memory on user upgradable SIMMs.

There are a lot of great old instruments contained in this box. We sincerely hope you enjoy rediscovering them and making them a part of your music.

Vintage Pro contains four user-upgradable sound SIMM sockets, allowing you to mix and match sound sets according to your needs. New sounds can be added as easily as plugging in a new 16MB or 32MB SIMM module and up to 128MB of sounds can be added! Each sound set has been meticulously crafted to be the best of its kind. Samples are matched across the keyboard, perfectly looped, and rich in harmonic texture.

Vintage Pro contains 512 user presets and can hold literally thousands of factory presets. *(ROM presets are automatically added when sound SIMMs are installed. As an example, a 32 MB SIMM may contain up to 1024 ROM presets.)* Vintage Pro's Sound Navigator is a major improvement to the main screen that makes it easy to find the exact sound you want from the thousands available. It's powerful, yet simple to use.

Vintage Pro contains E-MU's exclusive SuperBEATS Mode—a whole new way to create dynamic, original music. With SuperBEATS, you trigger, latch and unlatch synced loops and grooves from your keyboard. Simply select a "bts:" preset and you're ready to groove! Then use Vintage Pro's performance controls to alter and mutate the rhythm or the sound itself.

Then there's Vintage Pro's Rhythmic Pattern Generator/Arpeggiator, which can play up to 16 synchronized arpeggiator patterns at once using a different sound for each! Patterns can be edited using pattern flow commands such as: delay for 2 bars, play for 4 bars, hold for 2 beats and repeat. You can program or download 100 user patterns in addition to the 300 factory patterns.

Of course the real power of Vintage Pro becomes apparent when you begin to synthesize your own sounds. The extremely flexible yet easy to use, 4-layer synthesizer voices make it easy to build sounds of any kind. Layers can be switched or crossfaded using key position, velocity, real-time controllers or any modulation source. Vintage Pro also contains 50 different types of 2nd to 6th order resonant & modeling filters which are used to shape and modify the raw waveforms.

The 64 modulation sources include three multistage envelopes and two LFOs per layer, as well as full MIDI control over virtually every parameter. The digital patch bay, with 24 cords per layer, (and 12 more cords per preset) lets you connect modulation sources to 64 destinations in any imaginable way. The patch bay contains a set of arithmetic modifiers, letting you create complex synthesis models.

Four front panel real-time controllers give you control over 12 user-selectable parameters. The real-time knobs can adjust multiple synthesizer functions at once, allowing complex levels of control. For example, one knob can simultaneously turn up filter cutoff, while detuning one sample, and adjusting the release time of the volume envelope. Virtually every synth parameter in the Vintage Pro is controllable using the real-time knobs or by any internal or external control source.

Six analog outputs let you process separate sounds and integral effect sends externally. Returns allow the addition of external effects units without the need for a separate mixer.

Once you have created your preset, you can add richness to your sound using Vintage Pro's 24-bit stereo effects. You can choose a different effects setup for each preset from over 60 algorithms. Vintage Pro's effects section is actually two separate effects processors with control over each wet/dry mix level. Effects Processor "A" contains primarily ambiance algorithms like reverb and delays, while effects processor "B" contains primarily spectral algorithms such as chorus, flange, phase, distortion, and delay. Effects can be linked to each preset or used globally to further enhance your sound.

The S/PDIF digital stereo output lets you connect to other digital equipment, such as digital mixers or external effects devices, keeping your signal entirely in the digital domain.

Other features include multiple solo, voice assignment and performance modes for expressive control, 12 user-definable alternate tunings, an extremely easy to use interface and, of course, an extensive MIDI implementation.

## Overview

This is the Operations Manual for setting up and playing Vintage Pro. The first part of the manual describes how to unpack and setup the hardware.

The next chapters provide step-by-step instructions for the most common and widely used features of Vintage Pro. This section also defines each of the parameters (by menu) and provides information on how to use them.

The appendix provides technical information, product specifications and the Index.

# Important Safety Instructions

Use in countries other than the U.S.A. may require the use of a different line cord or attachment plug, or both. Refer all servicing to qualified service personnel. There are no user serviceable parts or adjustments inside the unit. There are no user serviceable parts inside the power supply enclosure.

**WARNING:** To reduce the risk of fire or electric shock, do not expose this product to rain or moisture.

## Grounding Instructions

This product must be grounded. If it should malfunction or break down, grounding provides a path of least resistance for electric current, reducing the risk of electric shock. This product is equipped with a cord having an equipment-grounding conductor and a grounding plug. The plug must be plugged into an appropriate outlet properly installed and grounded in accordance with all local codes and ordinances.

## Danger!

Improper connection of the equipment's grounding conductor can result in the risk of electric shock. Check with a qualified electrician or service personnel if you are in doubt as to whether the product is properly grounded. Do not modify the plug provided with this product. If it will not fit the outlet, have a proper outlet installed by a qualified technician.

## User Maintenance Instructions

1. The Vintage Pro should be kept clean and dust free. Periodically wipe the unit with a clean, dry, lint free cloth. Do not use solvents or cleaners.
2. There are no user lubrication or adjustment requirements.

**Caution** -*Service instructions are for use by qualified personnel only. To reduce the risk of electric shock, do not perform any servicing other than that contained in these operating instructions unless you are qualified to do so. Refer all servicing to qualified service personnel.*

## INSTRUCTIONS PERTAINING TO A RISK OF FIRE, ELECTRIC SHOCK, OR INJURY TO PERSONS



*This symbol is intended to alert you to the presence of important operating and maintenance (servicing) instructions in the literature accompanying the unit.*

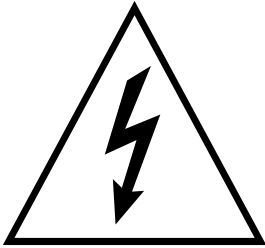

*This symbol is intended to alert you to the presence of uninsulated dangerous voltage within the product's enclosure that may be of sufficient magnitude to constitute a risk of electric shock to persons.*



*This symbol is intended to alert you to use caution when moving a cart/apparatus combination to avoid injury.*

**READ THESE INSTRUCTIONS:** When using electric products, basic precautions should always be adhered to, including the following:

1. Read all instructions before using Vintage Pro.
2. Keep these instructions.
3. Heed all warnings.
4. Follow these instructions.
5. Do not use this apparatus near water.
6. Clean only with a dry cloth.
7. Install in accordance with E-MU's instructions. Do not block any openings. This apparatus should be situated so that its location or position does not interfere with proper ventilation. The ventilation should not be impeded by covering the ventilation openings with items such as newspapers, tablecloths, curtains, etc.
8. Do not install near any heat sources such as radiators, heat registers, stoves, or other apparatus (including amplifiers) which produce heat.
9. Do not defeat the safety purpose of the polarized or grounding-type plug. A polarized plug has two blades with one wider than the other. A grounding-type plug has two blades and a third grounding prong. The wide blade or the grounding prong are provided for your safety. If the provided plug does not fit into your outlet, consult an electrician for replacement of the obsolete outlet.
10. Protect the power cord from being walked on or pinched, particularly at plugs, convenience receptacles, and at the point where they exit from the apparatus.
11. Use only attachments/accessories specified by E-MU Systems.
12. Use only with the cart, stand, tripod, bracket, or table specified by E-MU or sold with the apparatus. When a cart is used, use caution when moving the cart/apparatus combination to avoid injury from tip-over. It is recommended that Vintage Pro be rack mounted. You'll need (4) rack spaces to fit Vintage Pro into your rack.
13. Unplug the Vintage Pro apparatus from the power outlet during lightning storms or when left unused for a long period of time.
14. Refer all servicing to qualified service personnel. Servicing is required when the apparatus has been damaged in any way, such as power supply cord or plug is damaged, liquid has been spilled or objects have fallen into the apparatus, the apparatus has been exposed to rain or moisture, the apparatus does not operate normally or has been dropped.
15. No open flame sources, such as lit candles, should be placed on the apparatus.
16. The apparatus is designed for use in moderate climates.
17. The apparatus shall not be exposed to dripping or splashing. No objects filled with liquids, such as vases, shall be placed on the apparatus.
18. To reduce the risk of injury, close supervision is necessary when using the apparatus near children.

## Radio and Television Interference

19. The apparatus should be connected only to a power supply of the type described in the operating instructions and marked on the product.
20. This product, in combination with an amplifier and headphones and speakers, may be capable of producing sound levels that could cause permanent hearing loss. Do not operate for a long period of time at a high volume level or at a level that is uncomfortable. If you experience any hearing loss or ringing in the ears, consult an audiologist.

The equipment described in this manual generates and uses radio-frequency energy. If it is not installed and used properly—that is, in strict accordance with our instructions—it may cause interference with radio and television reception.

This equipment has been tested and complies with the limits for a Class B computing device in accordance with the specifications in Subpart J of Part 15 of the FCC rules. These rules are designed to provide reasonable protection against such interference in a residential installation. However, there is no guarantee that the interference will not occur in a particular installation, especially if a “rabbit ear” TV antenna is used.

If Vintage Pro does cause interference to radio or television reception, you can try to correct the interference by using one or more of the following measures:

- Turn the television or radio antenna until the interference stops.
- Move Vintage Pro to one side or the other of the television or radio.
- Move Vintage Pro farther away from the television or radio.
- Plug Vintage Pro into an outlet on a different circuit than the television or radio.
- Consider installing a rooftop antenna with a coaxial lead-in between the antenna and television set.



## Wichtige Sicherheitsvorschriften

In Ländern außerhalb der U.S.A. können andere Kabel oder Stecker notwendig werden. Überlassen Sie die Wartung qualifiziertem Fachpersonal. Im Geräteinnern befinden sich keine Bauteile oder Steuerungen, die vom Anwender gewartet werden können. Das Gleiche gilt für das Netzteilgehäuse.

**VORSICHT:** Um die Gefahr eines Brandes oder Stromschlages zu verringern, sollten Sie das Gerät weder Regen noch Feuchtigkeit aussetzen.

### Erdungs- instruktionen

Das Gerät muss geerdet sein. Bei einem Defekt oder Ausfall bietet die Erdung dem elektrischen Strom den Weg des geringsten Widerstandes und reduziert das Risiko eines Stromschlages. Dieses Gerät ist mit einem geerdeten Leiter und Stecker ausgerüstet. Der Stecker muss in eine passende, einwandfrei montierte und geerdete Steckdose in Übereinstimmung mit den örtlichen Vorschriften eingeführt werden.

### Gefahr!

Unvorschriftsmäßiger Anschluss des Gerätes kann zum Risiko eines elektrischen Schlages führen. Im Zweifel über die ordnungsgemäße Erdung sollte ein qualifizierter Elektriker oder eine Servicece-Stelle hinzugezogen werden. Ändern Sie den mitgelieferten Stecker nicht. Falls er nicht in die Steckdose passt, sollte die Installation einer neuen Steckdose nur durch einen qualifizierten Techniker erfolgen.

### Wartungs- instruktionen für Anwender

1. Der sollte sauber und staubfrei gehalten werden. Das Gerät mit einem sauberen und säurefreien Tuch periodisch abreiben. Keine Lösungs- oder Reinigungsmittel anwenden.
2. Schmierungen und Justieren sind nicht notwendig.

**Vorsicht:** Diese Gebrauchsanweisungen sind nur für qualifizierte Techniker bestimmt. Um die Gefahr eines elektrischen Schlages zu vermeiden, sollten Sie keine Arbeiten vornehmen, die nicht in diesen Instruktionen beschrieben sind. Wenden Sie sich bei weiteren Servicefragen nur an eine qualifizierte Servicestelle.



*Dieses Symbol weist Sie auf wichtige Bedienungs- und Wartungsanleitungen in den beiliegenden Drucksachen hin.*

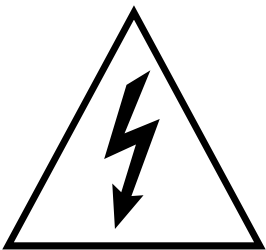

*Diese Symbol warnt Sie vor nicht-isolierten gefährlichen Spannungen im Gehäuseinnern. Diese können so hoch sein, dass die Gefahr eines Stromschlags besteht..*

## INSTRUKTIONEN ZUM BRANDRISIKO, STROMSCHLAG ODER PERSONENSCHADEN

**BITTE LESEN:** Beim Einsatz elektrischer Geräte sollten folgende Vorsichtsmaßnahmen stets beachtet werden:

1. Lesen Sie vor dem Einschalten des Vintage Pro alle Instruktionen.
2. Zur Vermeidung von Verletzungsrisiken müssen Kinder bei eingeschaltetem Vintage Pro sorgfältig überwacht werden.
3. Den Vintage Pro nicht in der Nähe von Wasser in Betrieb nehmen – z. B. in der Nähe von Badewannen, Waschschüsseln, auf nassen Gestellen oder am Swimmingpool.
4. Den Vintage Pro keiner tröpfelnden oder spritzenden Feuchtigkeit aussetzen. Keine mit Flüssigkeit gefüllten Objekte, wie Vasen, auf das Gerät stellen.
5. Den Vintage Pro stets so aufstellen, dass seine Belüftung nicht beeinträchtigt wird.
6. Den Vintage Pro nicht in der Nähe von Hitzequellen aufstellen, wie Heizkörper, offenem Feuer, Öfen oder von Backöfen.
7. Keine offenen Feuerquellen, wie Kerzen, auf dem Vintage Pro abstellen.
8. Der Vintage Pro ist nicht für den Einsatz in extremen Klimaverhältnissen konzipiert.
9. Den Vintage Pro ausschließlich mit einem Netzgerät gemäß Bedienungsanleitung und Gerätemarkierung verwenden.
10. Achten Sie darauf, dass keine Objekte oder Flüssigkeiten durch Öffnungen ins Vintage Pro Gehäuse gelangen.
11. Der Vintage Pro ist mit einem polarisierten Kabelstecker (mit zwei flachen Polen und einem Erdungsstift) ausgerüstet. Das geschieht zu Ihrer Sicherheit. Können Sie den Stecker nicht in die Steckdose einführen, ändern Sie nicht den Stecker ab, sondern wenden Sie sich an einen Elektriker, um die veraltete Steckdose ersetzen zu lassen.
12. Verlegen Sie das Stromkabel so, dass niemand darüber laufen oder stolpern und es nicht durch schwere Gegenstände geknickt werden kann. Achten Sie besonders auf Netzstecker, Mehrfachsteckdosen und den Kabelanschluss am Gerät.
13. Das Netzkabel bei Gewittern oder längerem Nichtgebrauch aus der Steckdose ziehen.
14. Dieses Gerät kann bei Verwendung von Kopfhörern und Verstärkern hohe Lautstärkepegel erzeugen, welche zu bleibenden Gehörschäden führen. Arbeiten Sie nicht während längerer Zeit mit voller Lautstärke oder hohem Pegel. Stellen Sie Hörverlust oder Klingeln in den Ohren fest, wenden Sie sich an einen Ohrenarzt.
15. Verwenden Sie nur die von E-MU Systems empfohlenen Befestigungen und Zubehörteile.
16. Überlassen Sie die Wartung qualifiziertem Fachpersonal. Das Gerät soll durch qualifizierte Fachkräfte gewartet werden, wenn:
  - A. das Netzkabel beschädigt wurde oder

- B. Gegenstände oder Flüssigkeit in das Gerät gelangten,
- C. das Gerät Regen ausgesetzt war oder
- D. das Gerät stürzte oder sein Gehäuse beschädigt wurde
- E. das Gerät nicht normal oder einwandfrei arbeitet oder Betriebsstörungen auftreten

## **Diese Instruktionen aufbewahren**

## **Alle Warnungen beachten**

## **Alle Instruktionen befolgen**

## **Radio und TV- Interferenzen**

Das in diesem Handbuch beschriebene Equipment verwendet und erzeugt Frequenzen im Radio/Fernsehbereich. Wird das Gerät nicht entsprechend den hier beschriebenen Regeln installiert, können Störungen im Rundfunk- und Fernsehempfang entstehen.

Das Gerät wurde getestet und entspricht den Regeln für Class B Computer entsprechend den Spezifikationen in Subpart J von Part 15 der FCC Bestimmungen. Diese sollten angemessenen Schutz vor solchen Interferenzen in Wohngebieten liefern. Es kann aber nicht garantiert werden, dass diese Interferenzen bei bestimmten Installationen nicht doch auftreten – besonders bei Verwendung von bestimmten TV-Zimmerantennen. Sollte der Vintage Pro den Radio- oder TV-Empfang stören, versuchen Sie mit folgenden Maßnahmen, die Ursache zu beheben.

- Bewegen Sie den Fernseher oder die Antenne, bis die Störungen verschwinden.
- Stellen Sie den Vintage Pro auf die jeweils andere Seite des TVs oder Radios.
- Stellen Sie den Vintage Pro weiter entfernt vom Radio oder TV auf.
- Verwenden Sie einen anderen Stromkreis für den Vintage Pro.
- Installieren Sie eine Dachantenne mit einer koaxialen Antenneneinführung zwischen Antenne und TV-Gerät.

## **Urheber- rechts- Infor- mationen**

Die Firmenpolitik von E-MU / ENSONIQ gestattet allen Anwendern freie, vollständige und uneingeschränkte Nutzung aller Presets, Beats, Riffs, Patterns und Audition-Dateien, die in unseren Produkten enthalten sind. Wir können Ihnen allerdings nicht erlauben, die Demo-Dateien erneut zu verwenden, zu modifizieren, darauf aufzubauen oder diese zu verkaufen/vertreiben. Meistens sind diese Kompositionen von den jeweiligen Autoren urheberrechtlich geschützt und an E-MU / ENSONIQ nur zur Produktdemonstration lizenziert. Setzen Sie sich bei weiteren Fragen bitte mit E-MU / ENSONIQ in Verbindung.

## Consignes de sécurité importantes

L'utilisation de l'appareil dans d'autres pays que les États-Unis peut nécessiter l'usage d'un cordon d'alimentation et/ou d'une prise différent(s). Consultez un technicien qualifié pour toute réparation. L'appareil et le dispositif d'alimentation ne contiennent aucune pièce réparable par l'utilisateur.

**ATTENTION** : Afin de réduire les risques d'incendie ou d'électrocution, n'exposez pas cet appareil à la pluie ou à l'humidité.

### Mise à la terre

Cet appareil doit être relié à la terre. En cas de dysfonctionnement, la terre fournit un passage de moindre résistance pour le courant électrique et réduit ainsi les risques d'électrocution. L'appareil Vintage Pro équipé d'un cordon d'alimentation muni d'un conducteur et d'une fiche polarisés. Cette fiche doit être insérée dans une prise secteur appropriée correctement installée et reliée à la terre conformément aux normes locales.

### Danger

Une mauvaise mise à la terre peut entraîner des risques d'électrocution. Consultez un électricien ou un technicien qualifié si vous avez des doutes quant à la mise à la terre de l'appareil. Ne modifiez pas la fiche du cordon d'alimentation fourni avec l'appareil. Si vous ne pouvez pas l'insérer dans la prise, adressez-vous à un technicien qualifié pour faire poser une prise du modèle adapté.

### Maintenance

1. Le Vintage Pro doit toujours être propre et maintenu à l'abri de la poussière. Nettoyez-le régulièrement à l'aide d'un chiffon sec, propre et non-pelucheux. N'utilisez pas de solvants ni de produits de nettoyage.
2. Aucune lubrification et aucun réglage ne sont nécessaires de votre part.

**Attention** : Les instructions de maintenance sont uniquement destinées à un personnel qualifié. Afin d'éviter tout risque d'électrocution, n'intervenez pas au-delà des instructions décrites dans ce mode d'emploi. Confiez toute réparation à un technicien qualifié.

## CONSIGNES RELATIVES AUX RISQUES D'INCENDIE, D'ÉLECTROCUTION OU DE BLESSURES CORPORELLES

**LISEZ CES CONSIGNES :** Lorsque vous utilisez des appareils électriques, certaines précautions élémentaires doivent toujours être respectées. En voici quelques-unes:



Ce symbole attire l'attention de l'utilisateur sur la présence d'instructions d'utilisation et de maintenance importantes dans le mode d'emploi fourni avec l'appareil

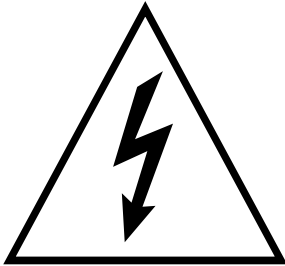

Ce symbole attire l'attention de l'utilisateur sur la présence de tensions élevées dans l'appareil, susceptibles de constituer un risque d'électrocution.

1. Lisez toutes les instructions avant d'utiliser le Vintage Pro.
2. Afin de limiter les risques de blessures, une surveillance particulière est nécessaire lorsque vous utilisez le Vintage Pro en présence d'enfants.
3. N'utilisez pas le Vintage Pro près de l'eau (près d'une baignoire, d'un lavabo, d'un évier, dans un sous-sol humide, sur une surface mouillée ou près d'une piscine, par exemple).
4. N'exposez pas l'appareil aux éclaboussures. Ne posez aucun récipient contenant de l'eau (vases, par exemple) sur le Vintage Pro.
5. Le Vintage Pro doit être placé de sorte que sa position ou son emplacement ne gênent pas sa ventilation.
6. Ne placez pas le Vintage Pro à proximité de sources de chaleur (radiateur, cheminée ou four, par exemple).
7. Ne posez aucune source incandescente (bougies, par exemple) sur le Vintage Pro.
8. Le Vintage Pro ne doit pas être utilisé dans des environnements à températures extrêmes.
9. Le Vintage Pro doit uniquement être connecté à une alimentation du type décrit dans le mode d'emploi et sérigraphié sur l'appareil.
10. Veillez à ce qu'aucun corps ou liquide étranger ne s'introduise dans le Vintage Pro.
11. Le Vintage Pro est équipé d'une fiche polarisée (une broche plus large que l'autre). Ce type de fiche constitue une mesure de sécurité. Si vous ne pouvez pas insérer la fiche dans la prise, contactez un électricien pour faire poser une prise du modèle adapté.
12. Faites circuler le cordon d'alimentation de sorte qu'il ne puisse pas être écrasé ou pincé par d'autres objets. Soyez particulièrement vigilant au niveau des connexions à l'appareil ou aux prises secteur.
13. En cas d'orage ou si l'appareil doit rester inutilisé pendant une période prolongée, débranchez le cordon d'alimentation du Vintage Pro de la prise secteur.
14. Cet appareil, associé à un amplificateur et à un casque ou des enceintes, est capable de délivrer des niveaux sonores susceptibles d'entraîner des pertes auditives irréversibles. Ne l'utilisez pas de manière prolongée à un niveau élevé ou inconfortable. En cas de troubles de l'audition ou de bourdonnement d'oreilles, consultez un spécialiste.
15. Utilisez uniquement les accessoires préconisés par E-MU Systems.

## Interférences radio et TV

16. Confiez l'appareil à un technicien qualifié dans chacun des cas suivants :
- A. Le cordon d'alimentation ou la prise a été endommagé.
  - B. Des corps étrangers ou du liquide se sont introduits dans l'appareil.
  - C. Le Vintage Pro a été exposé à la pluie ou à l'humidité.
  - D. Le Vintage Pro est tombé ou a été endommagé d'une manière ou d'une autre.
  - E. Le Vintage Pro ne fonctionne pas normalement ou présente une baisse sensible de ses performances.

**Conservez ces instructions.**

**Respectez tous les avertissements**

**Suivez toutes les instructions**

L'appareil décrit dans ce mode d'emploi génère et utilise des fréquences radio/TV. S'il n'est pas installé conformément aux instructions décrites, il peut interférer avec la réception TV ou radio.

Cet appareil a été testé et est conforme aux normes de Classe B selon les spécifications du paragraphe J de la section 15 des dispositions FCC. Ces dispositions sont conçues pour protéger les installations résidentielles contre ce type d'interférences. Toutefois, l'absence d'interférences ne saurait être totalement garantie avec certains types d'installations, en particulier si vous utilisez certaines antennes TV internes.

Si le Vintage Pro interfère avec la réception TV ou radio, vous pouvez essayer les mesures suivantes:

- Réorientez l'antenne ou le poste de télévision jusqu'à ce que les interférences disparaissent.
- Placez le Vintage Pro de l'autre côté du poste de télévision ou de la radio.
- Eloignez le Vintage Pro du poste de télévision ou de la radio.
- Branchez le Vintage Pro sur une prise différente de celle de la télévision ou de la radio.
- Installez une antenne sur le toit par le biais d'une connexion coaxiale entre l'antenne et le poste de télévision.

# Setup

## Unpacking

This section thoroughly describes how to set up your new Vintage Pro for use. Setup includes unpacking instructions and how to connect the Vintage Pro cables.

Carefully remove Vintage Pro from the packaging material. Take care to save the packing materials in case you need to transport the unit. Check to make sure all components are included and in good condition. If there are missing or damaged components, contact E-MU Systems immediately for replacement or repair.

The Vintage Pro box should include the following components:

- Vintage Pro
- Power cable
- Rack mounting ears
- This Operation Manual

# Connection Instructions

## Basic Setup

 If Vintage Pro does not seem to be responding correctly, make sure that both Vintage Pro and your MIDI controller are set to the same MIDI channel.

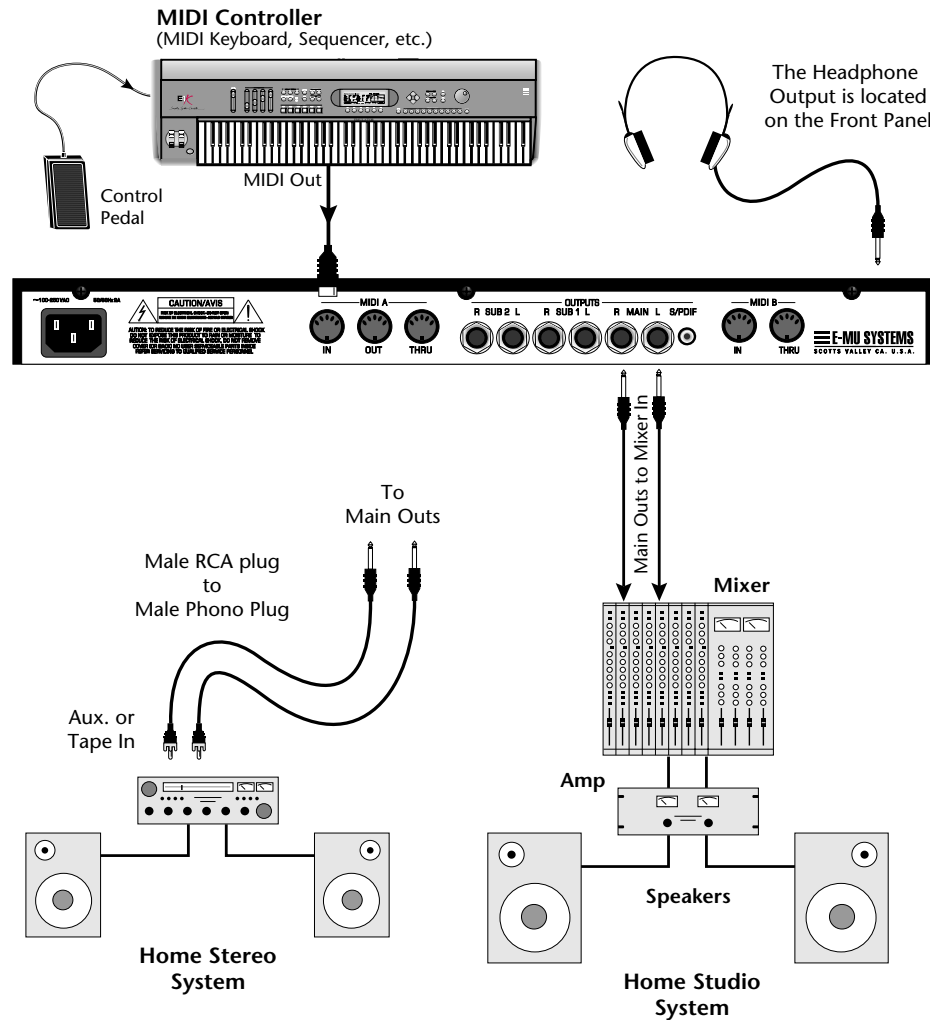

### MIDI In

Vintage Pro is controlled by MIDI messages received at the MIDI A jack. Normally you will connect MIDI Out of a controller such as a MIDI keyboard, MIDI wind controller or MIDI guitar controller to the MIDI A jack of Vintage Pro.

### Outputs

Vintage Pro is a high quality, stereo audio device. To reproduce its wide dynamic range and frequency response, use a high quality amplification and speaker system such as a keyboard amplifier or home stereo system. A stereo setup is highly desirable because of the added realism of stereophonic sound. Headphones can be used if an amplifier and speaker system is not available. Plug stereo headphones into the headphone jack located on the left side of the front panel. The Right Main output jack serves as a mono output when the Left Main plug is not plugged in. The Left Main output jack is a stereo jack carrying both channels. The S/PDIF output duplicates the function of the main output.



Studio Setup

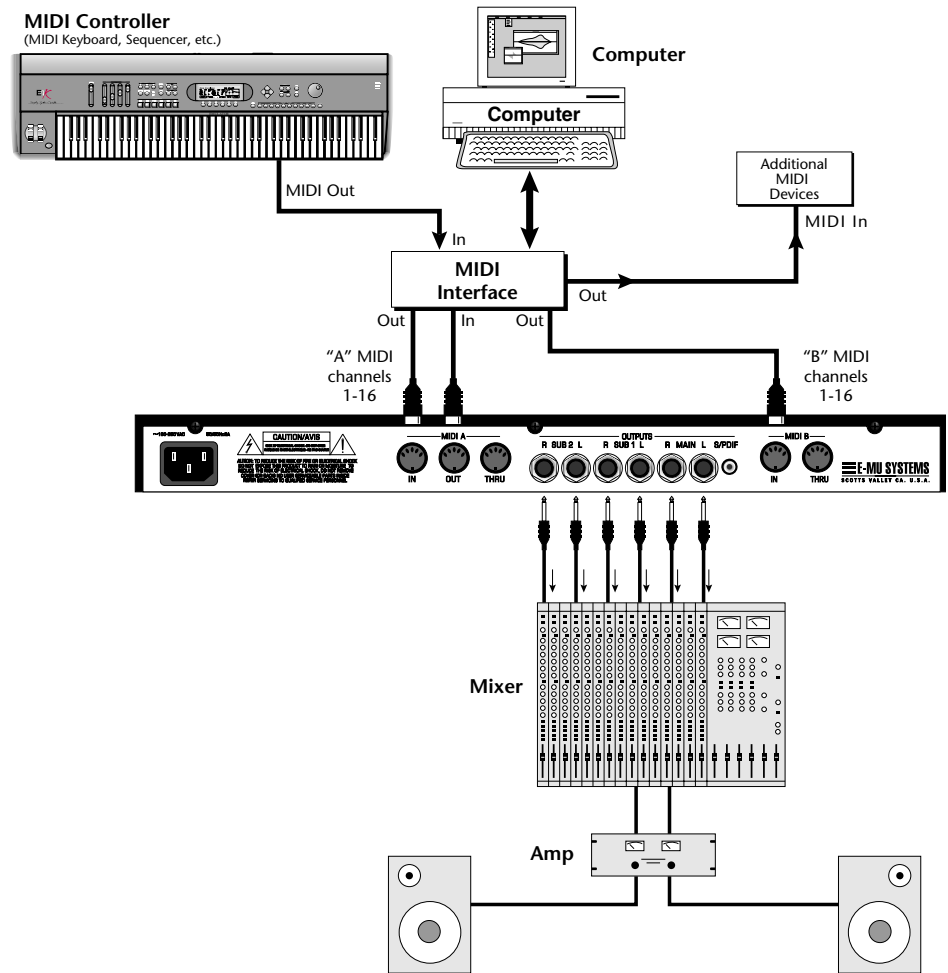

**MIDI In**

In this setup, Vintage Pro is controlled by MIDI messages, received at both MIDI A and MIDI B inputs, which are routed by the MIDI interface. Each MIDI input handles 16 MIDI channels for a total of 32 channels. The MIDI interfaces allow any MIDI controller, such as a MIDI keyboard or a computer, to control the module.

**MIDI Out**

The MIDI Out jack transmits program data to a computer or other device.

**Outputs**

Three sets of programmable stereo outputs (Main, Sub 1, and Sub 2) are provided. The internal effects are available only on the Main outputs. Specific presets (or MIDI channels) can be routed to one of these stereo pairs in order to be processed further or mixed separately. The S/PDIF output duplicates the function of the main output.

Performance Setup

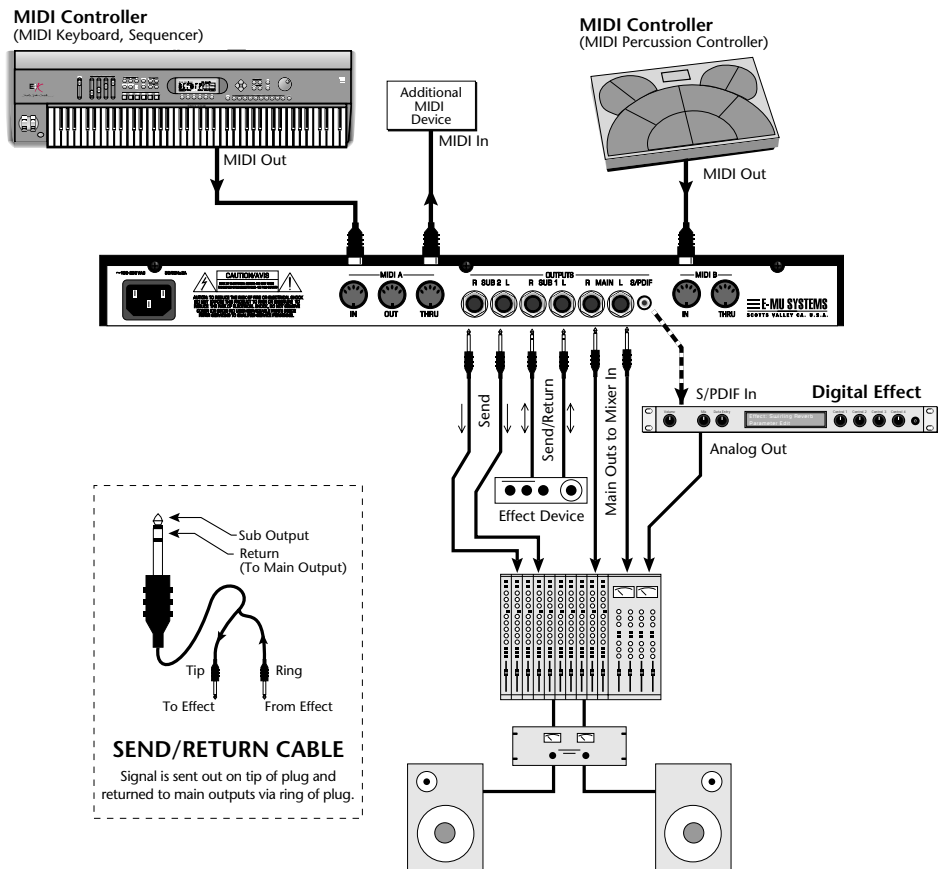

**MIDI In**

Vintage Pro is controlled by MIDI messages received at either MIDI input. In a live performance situation, you might want to use two MIDI controllers as shown above. Connect MIDI outputs of your MIDI controllers such as a MIDI keyboard, MIDI drum pads or a MIDI sequencer to MIDI Inputs A and B of Vintage Pro.

**MIDI Thru**

The MIDI Thru jack is used to connect additional MIDI devices onto the MIDI chain. MIDI Thru transmits an exact copy of the messages received at the respective MIDI In jack (A or B).

**Outputs**

The Sub 1 and Sub 2 output jacks are stereo jacks. The tip of each jack (accessed when a standard phone plug is inserted) connects to the left or right output of that group. The S/PDIF output duplicates the function of the main output.

If you insert a stereo plug into one of the Sub Outputs, the ring of the plug serves as a signal Return which sums into the Main outputs.

**Therefore, the Sub 1 and Sub 2 jacks can serve as effect sends and returns in order to further process selected instruments and then return them to the main mix.**

You can use the Sub 1 and Sub 2 jacks as send/returns in order to further process selected Vintage Pro presets without using the effects bus on the mixing board. In a pinch, the effect returns can be used to sum additional instruments into the main outputs. It's like having an extra line mixer when you need more inputs!

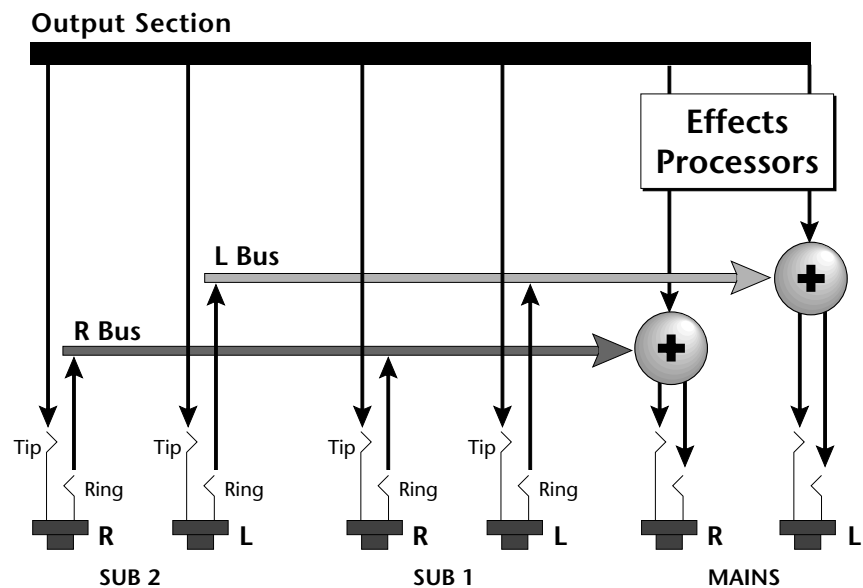

You can use the Sub 1 and Sub 2 jacks as effect returns to the Main Outputs.  
Note that the Effects Processors are only routed to the Main Outputs.

### *Power Up!*

The power switch is located on the right side of the front panel. You can turn on the Vintage Pro and its MIDI controller in any order. When power is applied the liquid crystal display will light, indicating that Vintage Pro is operating. You may have noticed that there is no 110/220 Volt power selector switch on Vintage Pro.

**Vintage Pro automatically switches itself to the proper line voltage.**

# Instant Gratification

## Playing Demo Sequences



**Demo Sequences**  
Mica's Dream  
Gen Xtra  
Neo Classic  
ProBros

## Auditioning Presets & Beats

This section presents step-by-step instructions for the most fundamental operations to get you up and making sounds quickly.

Vintage Pro has several factory demonstration sequences that let you hear what this incredible machine can do. The actual number of demo sequences depends on which ROM sounds sets are installed. You can play these demo sequences by accessing the Demo Sequence page.



### ► To Play a Demo Sequence

1. Press and hold the **Master** and **Edit** buttons at the same time to enter the Demo Sequence page. The screen shown above appears.
2. Select a sequence using the data entry control. The Enter LED will be flashing.
3. Press the Enter button to begin playing the selected sequence. The screen shown below appears.



4. Press the Enter button again to stop playing the sequence.
5. When a demo sequence plays to the end, the next demo will automatically begin playing. The screen will display the new demo name.
6. With the sequence stopped, press either the Master or Edit button to Exit the demo sequence mode.

The front panel audition button allows you to hear any preset in Vintage Pro without even hooking up a MIDI keyboard! When the Audition button is pressed, the LED next to the button will illuminate and a short "Riff" (programmed as part of the preset) will play. The Riff is latched on and plays continuously until the button is pressed again. Presets can be changed while Audition is latched on. Beats presets will play their Beat Riff.

The top line of the display changes to show the MIDI Bank Select controller values needed to select the preset being auditioned. This is an extremely handy feature when sequencing.

Selecting and Quick  
Editing Presets

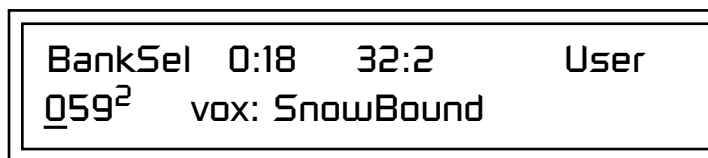

► To Audition a Preset

1. Select a preset by turning the data entry control while the cursor is anywhere on the lower line. The preset number field (shown above) is the normal position of the cursor and pressing the Enter button will return the cursor to this position.
2. Press the Audition button on the front panel. The Audition LED will illuminate and a short riff will play the selected preset.
3. Continue to select and audition presets.
4. Press the Audition button again to turn Audition mode off. The LED will extinguish.

The first thing you'll do with the Vintage Pro is select and play the factory provided presets. Vintage Pro comes standard with 12 banks containing 128 presets each.

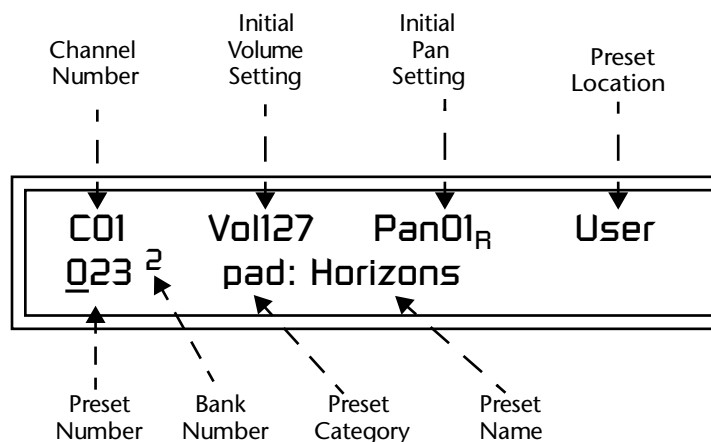

The first four banks are USER locations that can be overwritten and used to store your own presets. The presets that come stored in the USER presets are duplicated in banks 0-3 of the "VROM" ROM bank, so feel free to overwrite them with your own presets. You won't be losing anything.

The ROM Card identifier is shown in the top right of the display. The preset is identified in the bottom line of the main screen (the screen that appears when you first power up the unit).

Each bank of 128 presets is identified by a superscripted *Bank Number* to the right of the preset number. The bank numbers reset to 0 at the start of each ROM card you have installed. So with the composer ROM installed, the USER banks will go from 0-3, then start over from 0-3 for the VROM banks.

To the right of the preset number and bank is the preset *Category* name followed by the *Preset Name*.

► **To Change the Preset**

1. Place the cursor under the first character in the Preset Number field. This is the “Home” position which is selected instantly when you press the Home/Enter button. Pressing either of the two cursor buttons repeatedly also gets you there.
2. Turn the Data Entry Control knob on the front panel to select a new preset number. If you turn the knob slowly, the presets advance one number for each “click” of the knob. If you spin the knob quickly, the numbers advance much faster (more than one number per click).
3. Play the keyboard (or press the Audition button) and listen to the sounds made by your Vintage Pro!
4. **TURN THE FOUR KNOBS** on the front panel and note how they change the sound of each preset! The button to the left of the knobs changes the knob’s function. Don’t worry about ruining the sound, the values are automatically reset as soon as you select a new preset.

 You can select presets from the Preset Number, Bank Number, Preset Category or Preset Name fields.

The User Banks are duplicated in the VKEYS ROM bank.

| Bank Organization |        |             |
|-------------------|--------|-------------|
| <b>USER</b>       | Bank 0 | 128 Presets |
| <b>USER</b>       | Bank 1 | 128 Presets |
| <b>USER</b>       | Bank 2 | 128 Presets |
| <b>USER</b>       | Bank 3 | 128 Presets |
| <b>VROM</b>       | Bank 0 | 128 Presets |
| <b>VROM</b>       | Bank 1 | 128 Presets |
| <b>VROM</b>       | Bank 2 | 128 Presets |
| <b>VROM</b>       | Bank 3 | 128 Presets |

The four User Banks can hold 512 custom presets. Feel free to overwrite these since the factory user presets are duplicated in nonvolatile ROM.

# Basic Operations

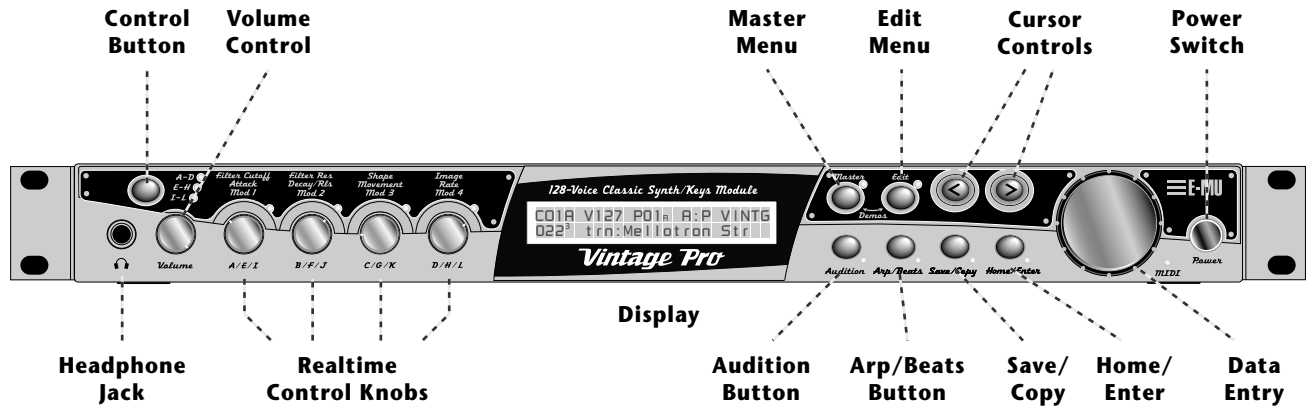

## Front Panel

The Vintage Pro front panel contains an LCD screen, nine buttons and four real-time controllers. Functions are grouped logically and the controls are arranged for ease of use. Precisely because Vintage Pro is so simple to use, you might be tempted to skip this section. If you just can't help yourself, at least read the Real-time Controller information beginning page 23. There are several "power user" features in the interface which make programming even easier and we wouldn't want you to miss them.

### Volume Control

This control is the master volume control for all audio outputs. The Volume Control does not affect any editing or user interface operations.

### Master Button

The Master menu contains parameters that affect the entire machine, not just certain presets. An illuminated LED to the right of the button indicates that you are in the Master menu.

### Edit Button

Use the Edit menu when you want to create or modify a preset. An illuminated LED to the right of the button indicates that you are in the Edit menu.

### Control Button

The Control button is used to change the function of the Controller knobs (see the next section). Each time you press the Control button, the Control Mode toggles to select only one of the three Control Rows. The currently selected Control Row is indicated by one of the three LEDs to the right of the row's label.

## Audition Button

 See "Bank Select Commands" on page 110 for more information on selecting banks via MIDI.

The Audition button allows you to hear any preset without hooking up a MIDI keyboard. When the Audition button is pressed, the LED next to the button will illuminate and a short "Riff" (programmed as part of the preset) will play. The Riff is latched on and plays continuously until the button is pressed again. Presets can be changed while Audition is latched on.

The top line of the display changes to show the MIDI Bank Select controller values needed to select the preset being auditioned. This handy feature lets you know the exact Bank and Preset number to enter into your sequencer.

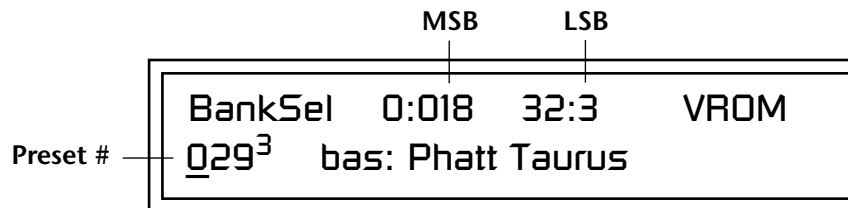

## Left/Right Cursor Buttons

These buttons move the cursor to the next parameter on the display. (The cursor is a little flashing line underneath one of the parameters in the display.) Press either cursor button until the cursor is underneath the desired parameter. The cursor buttons have an auto-repeat feature which advances the cursor when the button is held continuously.

The cursor can be moved bidirectionally using the Data Entry Control while either cursor select button is held down (for example, press and hold the right cursor button and turn the Data Entry Control).

## Arps/Beats Button

The Arps/Beats button allows you access to the Arpeggiator/Beats menu.

The **Arpeggiator** moves a pattern of notes sequentially over a range of the keyboard. Vintage Pro has the unique ability to play a different arpeggiator on each MIDI channel!

**Beats** mode is a 16-track play-only sequencer that is optimized for live performance and groove creation. Each of the 16 parts is assigned to a trigger key on the selected Trigger MIDI channel. Each part is brought in or out by pressing that key.

## Save/Copy Button

The Save/Copy button is used to save or copy presets and to copy data. Selected groups of parameters, such as PatchCord settings, can be copied between Presets and/or between Layers using this menu.

The **Multisetup** controls are also located under the Save/Copy menu. A Multisetup is a group of parameters that you might associate with a particular sequence or song. It is like a "snapshot" of the current configuration of the module. There are 64 setups numbered 0-63.



### *Home/Enter Button*

The LED to the right of the button illuminates to indicate that you are in the Save/Copy menu. The LED also illuminates when any preset parameter has been changed in the Edit menu (or if the front panel knobs have been moved with Quick-Edit mode enabled).

The Home/Enter button is dual purpose. In general, this button acts as the “Home” button. For example, when in an Edit menu, this button snaps the cursor to the page name field of the current screen. When viewing the Preset Select screen (we also call it the main screen), this button snaps the cursor to the preset number field. In these instances, the LED is not used.

Some screens and parameter fields use this button as the “Enter” button. In these cases, the LED blinks when the cursor is moved to one of these fields indicating that the module is waiting for your response to initiate the operation.

### *Data Entry Control*

The Data Entry Control is a stepped, variable control switch used to change parameter values. The wheel increments or decrements the current value one unit with each click. This control incorporates acceleration, which advances the value faster if the Data Entry Control is turned quickly.

### *Controller Knobs*

Each of the four Real-time Controller knobs has a corresponding LED to its upper right side. The function of the Real-time Controllers depends on which row is currently selected and the programming of the preset.

## **Front Panel Controller Modes**

The Real-time Controller Knobs serve three purposes:

1. Real-time control of synthesizer parameters
2. “Quick Editing” the initial settings of the real-time controllers
3. “Deep Editing” the parameters

This section describes each of the three uses.

### *Real-time Control*

The Real-time controller knobs provide direct control of the Vintage Pro’s synthesizer parameters. They are always active when on the Preset Select (main) screen. They can optionally be used to transmit MIDI controller messages to other MIDI devices.

The Control button (left of the knobs) changes the function of the real-time controller knobs. Each time the button is pressed, the Control Mode toggles to select one of the three Control Row groups. The currently selected Control Row is indicated by the illuminated LED to the right of the button. The control knob functions are determined by the selected Control Row.

The three Control Rows generate MIDI data that can control the preset on the current MIDI channel (the channel showing on the Preset and main screen. The labels (Tone, Presence, Shape, Image, etc.) printed on these rows show how the factory ROM presets may be programmed to respond. (*The controls might not conform to the front panel labels depending on the preset.*) You can change the way a preset responds to MIDI A-L messages from the Edit menu (PatchCords).

There is an LED next to each of the control knobs which illuminates to indicate that the knob setting has been changed from the value programmed in the preset (when Quick Edit mode is enabled). If the knob position is returned to the original setting, the LED is extinguished.

If the “*Knobs MIDI Out*” parameter in the Master menu (see “Knobs/Riff MIDI Out” on page 78) is set to “transmit,” the system sends a MIDI controller message when you turn off the Control knob. The MIDI controller message is sent on the current MIDI channel (also called the basic channel) using the controller number assigned in the Master menu (see “Real-time Controller Assignment” on page 75).

The knobs only generate a message when you move a knob to a new value. The current value jumps to the new value.

## Quick Edit

This mode uses the Controller knobs to “Quick-Edit” the currently selected preset without having to enter the Preset Edit menu. This mode is only active when on the Preset Select screen and when “*Quick-Edit*” is enabled in the Master menu (see “Knob Preset Quick-Edit” on page 77).

Initial controller values can be stored in every preset. When you move a knob with Quick-Edit enabled, the Initial Controller Value is updated with the knob’s new value. The knob’s LED lights indicating that the preset value has been changed. The three Control Rows’ MIDI A-L values are stored in the corresponding *Initial Controller Amount* parameter in the Edit menu (see “Initial Controller Amount” on page 153). The Save/Copy button LED illuminates to remind you that the preset has been edited. “Quick-Edits” made to a preset are lost if you select another preset before saving them.



*Quick-Edit mode must be enabled in the Master menu.*

### ► To Quick-Edit a Preset

1. Use the Control Knobs to change the sound of the current preset as desired.
2. Press the Save/Copy button. The display reads, “Save Preset to.”
3. Press the right cursor button to select the bottom row.
4. Optional: Select a new preset location if you don’t want to overwrite the current preset, or if the current preset is a ROM preset.
5. Press the Enter button to save the preset.

## Deep Edit Mode

When in the Master, or Edit menus, you can use the Controller Knobs to edit parameters. Using the Controller Knobs is a faster method for entering data, but the Data Entry Control offers finer precision.

### ► To Enable Deep Edit Mode:

1. Press the Master button and use the Data Entry Control to advance to the “Knobs Deep Edit” screen as shown in the following illustration.



2. Press either Cursor key to move the cursor to the bottom line in the display.
3. Use the Data Entry Control to change the value to “enabled.”
4. Press the Master menu button to exit the Master menu.

### When you enter any of the Edit menus:

1. The four Controller Knobs are used for editing.
2. All the Controller LEDs are off.
3. All the Control Row LEDs are off.

When you turn a knob, the field value jumps to the current knob value. You can still use the Data Entry Control for editing by moving the cursor to the desired field.

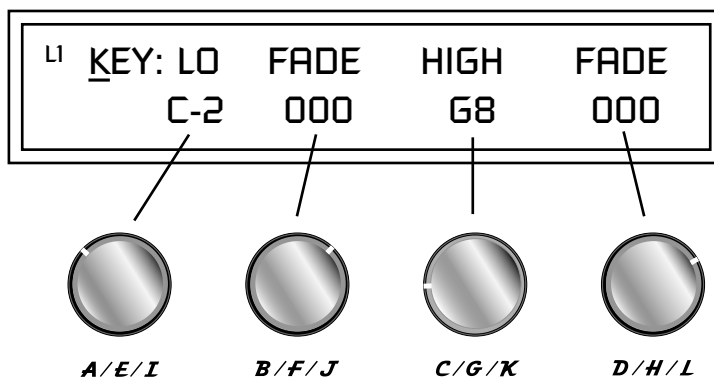

To move through menus horizontally, use the Data Entry Control (the page’s title field is the default cursor position). To move through menus vertically (preset layers), press the left cursor to get to the layer field, then change layers with the Data Entry Control.

- Use the Data Entry Control to move through menus (horizontally) or layers (vertically).
- Use the Controller Knobs to change parameter values within each page.

# Main Screen

The Preset Select screen is Vintage Pro's default screen (also called the main screen) and is active when you have not selected any of the other button-activated menus. From this screen you can change or examine the Preset, Volume, Pan Position and Preset Location for each of the 32 MIDI channels.

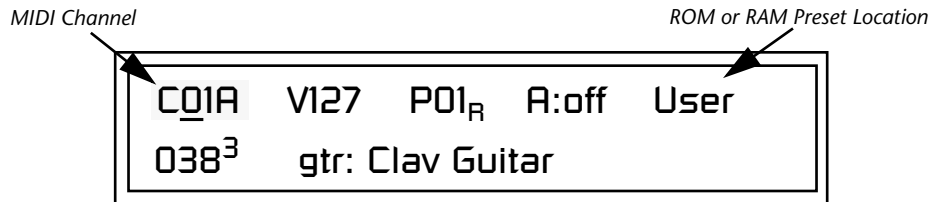

## MIDI Channel Selection

 The channel number shown in the main screen is the "basic MIDI channel" when in Omni or Poly modes.

### ► To Change the MIDI Channel

1. Press either cursor button until the cursor is underneath the channel number. (The cursor is the little flashing line underneath one of the parameters in the display.)
2. Rotate the Data Entry Control to select a MIDI channel (01A-16A, 01B-16B). As the channel number changes, the display changes to show the preset, volume, pan and preset location associated with the displayed channel.

## Preset Selection

| Bank  | Contents                           |
|-------|------------------------------------|
| 0     | – 128 RAM Presets                  |
| 1     | – 128 RAM Presets                  |
| 2     | – 128 RAM Presets                  |
| 3     | – 128 RAM Presets                  |
| ROM 1 | 0 – 128 ROM Presets                |
|       | 1 – 128 ROM Presets                |
|       | 2 – 128 ROM Presets                |
|       | ⋮                                  |
|       | ?? Depending on ROM sets installed |

### ► To Change the Preset

1. Press either cursor key until the cursor is underneath the preset number. (The cursor is a little flashing line underneath one of the parameters in the display.) As you rotate the Data Entry Control, the preset number and name changes.
2. The displayed preset is assigned to the displayed MIDI channel. Presets are arranged into banks of 128, as shown in the diagram at left.

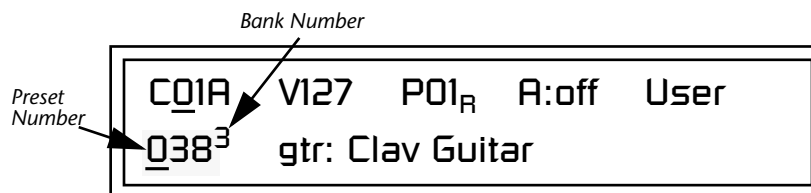

Using the screen above as an example, the superscripted number 2 in the second line of the display identifies the current bank number.

- Select banks independently of the of the preset number by locating the cursor on the Bank field and turning the Data Entry Control.

## Channel Volume

Channel Volume sets the volume of the selected MIDI channel in relation to the other channels. This is the same parameter as MIDI volume control #7, and changes made over MIDI are shown in the display.

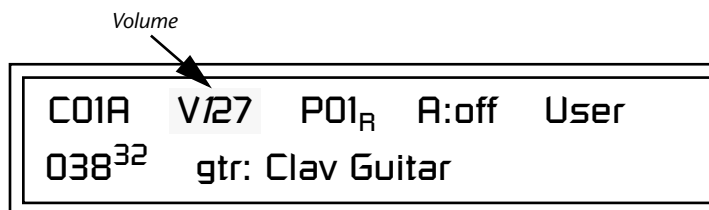

### ► To Change the Channel Volume

1. Press either cursor key until the cursor is underneath the volume value.
2. Rotate the Data Entry Control to select a volume level. The Channel Volume range is 000-127.

## Channel Pan

Channel Pan sets the stereo position of the selected MIDI channel. This control operates like the balance control on your home stereo system. Channel Pan is the same parameter as MIDI pan controller #10, and changes made over MIDI are shown in the display.

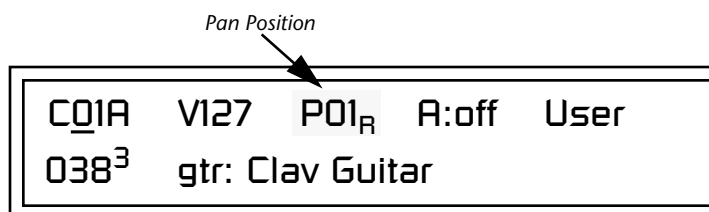

**Note:** Pan settings in the preset ADD algebraically with the Channel Pan setting. Therefore, if the pan setting in the preset were set to "63R," moving the Channel Pan setting full left would return the sound to the center position.

### ► To Change the Channel Pan

1. Press either cursor key until the cursor is underneath the pan field.
2. Rotate the Data Entry Control to select a pan value. 64L indicates a hard left pan, 63R indicates a hard right pan. With a setting of "00," the sound is centered in the stereo field.

## Channel Arpeggiator

This function controls the arpeggiator for each MIDI channel. When the channel arpeggiator mode is set to Off, then there is no arpeggiation on that channel, regardless of what is set up in the Master Arpeggiator or preset. If the channel arpeggiator is On, the preset's arpeggiator is used, regardless of whether or not it is turned on in the Edit menu. This lets you turn on arpeggiation from the main screen.

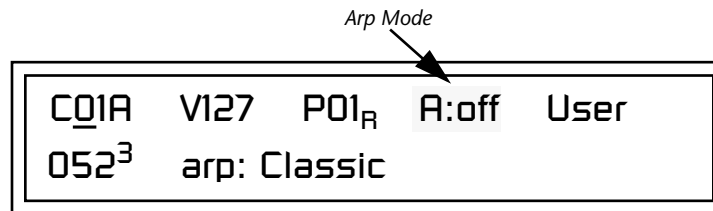

If the mode is set to “P” (for preset), the preset’s arpeggiator settings and on/off status is used. If the mode is set to “M” (for master), the master arpeggiator settings and on/off status (located in the Arp/Beats menu) are used. See “Arpeggiators” on page 47 for more information.

### ► To Play the Arpeggiator (Quick Start)

1. From the main screen, press either cursor key repeatedly until the cursor is underneath the arpeggiator field (A:).
2. Rotate the Data Entry Control to select “P” for preset.
3. Press either cursor key repeatedly until the cursor is underneath the Preset Category field and select “arp:” using the data entry control.
4. Press the right cursor button to move it to the Preset Name field.
5. Play notes or chords on the keyboard. Change presets as desired to audition the various patterns and presets.

# Sound Navigator

## Preset Category

Sound Navigator allows you to search through preset and instrument categories to find the type of sound you're looking for. Each preset and instrument has a name and a three letter preset category. You can create your own categories in order to group favorite presets. The preset category is assigned in the Edit menu (Preset Name). Instrument categories are fixed.

When you want to find presets in a particular category, you simply change the category field in the main screen, then move the cursor to the preset name field to scroll through all the presets in the selected category.

When the cursor is on the Preset Category field, turning the Data Entry Control selects different preset categories. The Name Field will change to show the first preset in each category.

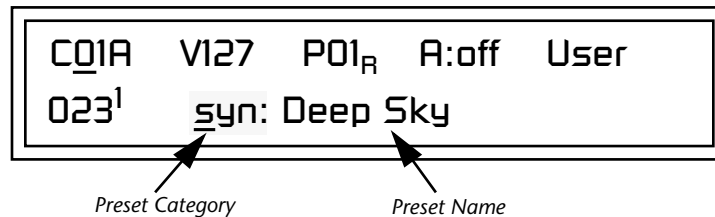

### ► To Change the Preset Category

1. Press either cursor key repeatedly until the cursor is underneath the preset category field.
2. Rotate the Data Entry Control to select one of the preset categories. Preset Categories are displayed in alphabetical order.

### ► To Select a Preset within a Category

1. After selecting a category, move the cursor to the Preset Name field.
2. Rotate the Data Entry Control to scroll through the presets in the selected category. Note that the preset numbers will no longer change sequentially.

## Instrument Category

When the cursor is on the Instrument Category field (Edit menu), turning the Data Entry Control selects different instrument categories. The Name Field changes to show the first instrument in each category. Move the cursor back to the instrument number to select instruments in the selected category.



# Multitimbral Operation

 Save the Multisetup using the instruction provided in Chapter 9: Save/Copy.

Multitimbral operation means that Vintage Pro can play more than one sound at the same time. Follow these instructions to access multiple presets on different MIDI channels simultaneously.

## ► To Set Up Vintage Pro for Multitimbral Operation

1. Set the MIDI mode to “multi mode,” using the MIDI mode function in the Master menu.
2. Decide which MIDI channels you want the Vintage Pro to receive (32 channels can be used simultaneously). If you are using 16 MIDI channels or less, just use the “A” MIDI port. Use both MIDI ports if you need more than 16 MIDI channels. You can turn any unused channels OFF using the MIDI Enable function in the Master menu.
3. Select the desired preset for each of the MIDI channels you want the Vintage Pro to receive using the MIDI Channel/Preset selection screen (see previous instructions).
4. Vintage Pro now responds multitimbrally on each of the MIDI channels you have specified. The volume and pan position parameters can be adjusted over MIDI (for each MIDI channel) or using the Cursor and Data Entry Control in the Preset Select screen.

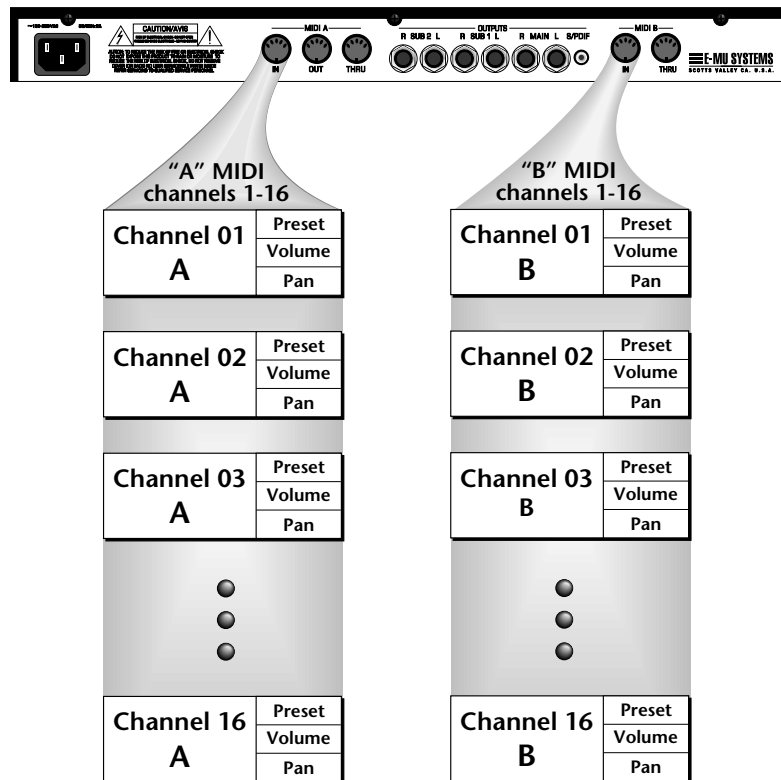

Vintage Pro has two MIDI inputs with 16 MIDI channels each. Each of the 32 MIDI channels can be assigned to play a specific preset with unique volume and pan settings.



# Arp/Beats Menu

The Arp/Beats button lets you access the Arp/Beat menu. This menu contains several different sections.

The Mix screens show you the volume and pan levels for all 32 MIDI channels at once.

SuperBEATS Mode is a whole new way to create dynamic, original music. BTS riffs are special multi-part Audition Riffs are permanently stored in sound ROM. With SuperBEATS, you trigger, latch and unlatch synced loops and grooves from your keyboard. Any preset can be selected and used by assigning a BTS riff (*or KIT riff*) in the Preset Edit menu.

Vintage Pro can also run up to 16 simultaneously synced arpeggiators, each with a different preset sound. The arpeggiators can either play one of 7 chord arpeggios or can be set to play a pattern, which is a stored sequence of notes.

All arpeggiators share Vintage Pro's master clock and its current setting. The master clock can be Vintage Pro's internal clock or an external MIDI clock (page 33). Although the arpeggiators use the master clock setting, the tempo divisor can be unique for each arpeggiator setup.

Arpeggiator modes include up, up/down, forward assign, backward assign, forward/backward assign and random as well as play *Patterns*. Patterns are pre-recorded sequences of notes and rests. All key-on notes play the pattern. For example, if you play a chord, all the notes in the chord play the pattern in harmony. Vintage Pro contains 300 factory patterns and 100 user definable patterns. Combined with SuperBeats, the sheer number of musical permutations is staggering!

**▶ To Enable the Arp/Beats Menu**

Press the Arp/Beats button, lighting the LED. The screen displays the menu page most recently selected since powering up Vintage Pro. The cursor appears below the first character of the screen heading on line one.

**▶ To Select a New Screen**

Press the Home/Enter button or press the Cursor button repeatedly until the cursor is below the screen title heading. Rotate the Data Entry Control to select another screen.

**▶ To Modify a Parameter**

Press either Cursor button repeatedly (or hold down the left or right cursor button while turning the Data Entry Control) until the cursor is below the desired parameter value. Rotate the Data Entry Control to change the value.

**▶ To access a Arpeggiator submenu:**

The Arpeggiator screens have submenus which are accessed by pressing the cursor buttons to move the cursor to the lower left corner of the display. Select the submenu function using the data entry control.

**▶ To save Arpeggiator parameters:**

Press the front panel Arp/Beats button to exit the module. The act of exiting the Arp/Beats module automatically saves your edited arp. Save the Multisetup to save your arp performance parameters.

**▶ To Return to the Main Screen**

Press the Arp/Beats button, turning off the LED.



*Arp parameters are automatically saved to the current multisetup when you exit the menu, but you may wish to save to another location.*

*If another Multisetup is "Restored" any unsaved changes will be lost if you haven't saved the Multisetup. See "Multisetups" on page 192.*

## Base Tempo

Vintage Pro contains an internal master clock which can be used to: synchronize the LFOs when in Tempo-based mode, control the times of Tempo-based envelopes or used as a modulation source in the PatchCords section. There are two tempo values shown in the display.

- **Base Tempo** - The base tempo is the value to which the MIDI controller specified in the Tempo Controller screen will be applied. (See “Tempo Controller” on page 77.)
- **Current Tempo** - The current tempo is equal to the base tempo modulated by the MIDI controller specified in the Tempo Controller screen. If no MIDI Tempo controller message has been received since the last Base Tempo change, the Current Tempo will be equal to the Base Tempo.

Current Tempo is NOT displayed when the Base Tempo is set to “use MIDI”.

### ► To Change the Master Tempo:

1. Move the cursor to the lower line of the display.
2. Adjust the Base Tempo using the Data Entry Control.

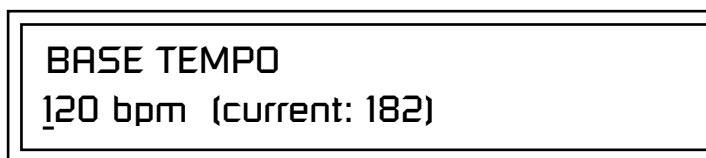

The Master Tempo values range from 1 through 300 beats per minute (BPM) or you can select “use MIDI clock” to use an external MIDI clock source.

### ► To Use an External MIDI Clock:

1. Move the cursor to the lower line of the display.

Turn the data entry control all the way counter-clockwise and select “**use MIDI**” to use an external MIDI clock source.

# Beats

Vintage Pro contains a 16-track play-only sequencer that is optimized for live performance and groove creation. Vintage Pro contains dozens of special 16-part Beats Riffs created by some of the best producers in the business. Beats Riffs are normally used in conjunction with a “bts:” preset containing the appropriate percussion mapping, but any preset can be selected and used.

The Beats channel is selected from the Beats enable screen in the Arp/Beats menu.

Here’s how it works. Each of the 16 parts is assigned to a keyboard trigger key on the selected Trigger MIDI channel. Each part is brought in or out by pressing that key. Keys can also be Latched (*press the key once to turn the part on, press it again to turn the part off*). Other control keys allow you to Mute All Parts, Clear All Parts, and Start & Stop the beat. The 16 parts are arranged in the following manner:

| Main Groove | Alt. Groove | Perc / Fills    | Instr/Wild      |
|-------------|-------------|-----------------|-----------------|
| 1. Kick1    | 5. Kick2    | 9. Perc3/Fill1  | 13. Inst1/Wild1 |
| 2. Snare1   | 6. Snare2   | 10. Perc4/Fill2 | 14. Inst2/Wild2 |
| 3. Hihat1   | 7. Hihat2   | 11. Perc5/Fill3 | 15. Inst3/Wild3 |
| 4. Perc1    | 8. Perc2    | 12. Perc6/Inst. | 16. Bass        |

For each Beats Riff, you have 2 Grooves, 4 Fills which correspond to the four parts of the Main and Alternate groove, and 4 Instrument parts. By adding and removing parts, you control the complexity of the groove.

Each part can also be scaled by *Key Velocity*, allowing you to fade parts in and out (if velocity is routed to volume) as you play, or can be *Transposed* over a six octave range.

Each part can be assigned to any one of four *Groups*, which allow multiple parts to be triggered from a single key. You can only access Groups using the keyboard trigger keys. See the Factory Setup diagram on the next page.

The factory **bts:** presets range from 4-16 bars long, using 4 to 16 tracks each. Normally you’ll use the Command Function buttons to bring parts in and out. Beat Parts can also be assigned to groups so that multiple parts can be triggered from a single key press. The Group Triggers, Clear Parts, Trigger Hold and Mute keys are only accessible via MIDI or the keyboard.

Trigger layouts are saved with the Multisetup. The Factory Multisetup (63) has all the Beats controls assigned to the keyboard as shown in the diagram on the following page. These MIDI note numbers have been placed below the lowest key on the keyboard so as not to interfere with normal playing. Setting the Beats Keys Offset function (*page 41*) to +36 will allow you to access these hidden control keys.



*Beats (bts:) Riffs are special 16-part riffs made especially for use with Beats mode. A Riff without the bts: prefix only has Part 1 recorded.*

## Factory Setup

Multisetup 63

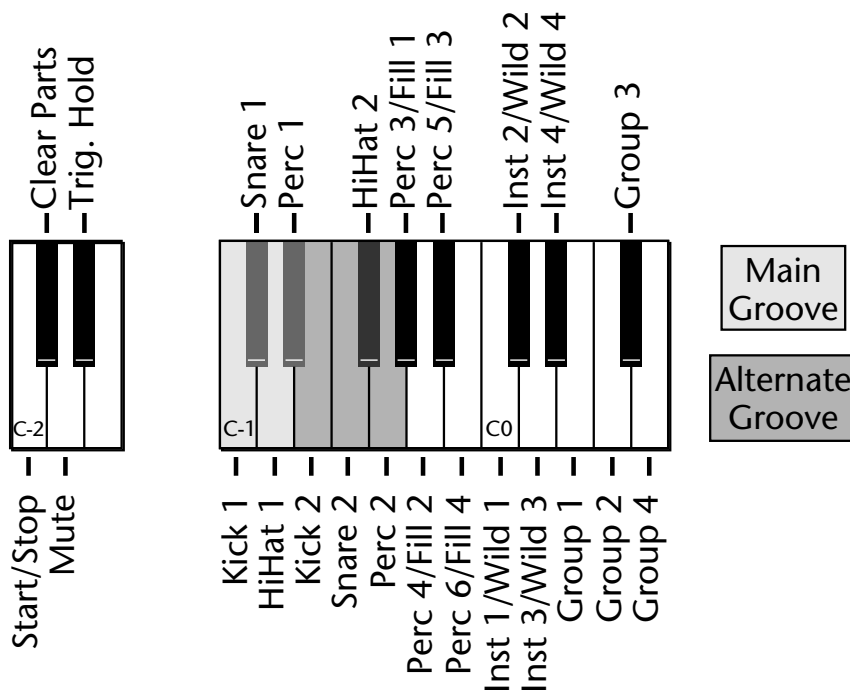

The chart above shows the Factory Multisetup assignment of each Part, the 4 Groups and the Control Keys. These assignments can be modified to suit your personal preference, then saved in one of the Multisetup locations.

 Starting Beats mode with the Start/Stop key allows you to start the sequencer rolling silently. Then you can bring Parts in and out using the “Busy” control.

 If Mute is set to 1-bar, the Part mutes for 1 bar then un-mutes.

- **Start/Stop Trigger** Starts the beat sequencer from the beginning of the sequence. When latched, pressing once starts and pressing again stops. When unlatched, the sequence runs as long as the key is held. Once the Beats sequencer is started, it continues to run even if no triggers are active. Start/Stop doesn’t clear latched parts when it stops the sequencer. Any trigger played after stopping will not only start the sequencer and play that trigger’s part, but also play all previously latched parts.
- **Clear Parts** Clears any enabled parts. This control provides a quick and easy way to shut off all latched Parts. Latch mode has no effect on this key.
- **Mute** Mutes all Parts while held, but the Beats sequencer continues running.
- **Trig Hold** When this key is held, all other Trigger Keys behave as if they were in Latch mode.

## Beats Mode

The Beats sequencer plays as long as any Beats triggers are active. Beats Riffs can also be **Restarted** using a MIDI Song Start command even if the Beats channel is not currently selected. The Audition LED illuminates whenever the Beats sequencer is running (even if no Parts are playing).

Pressing the Audition button or starting a Demo causes the Beats sequencer to stop. Pressing the Audition button plays selected Parts on “bts:” presets.

**All Arp/Beats parameters are saved with the Multisetup.** (See “Multi-setups” on page 192 for more information.)

This screen turns Beats mode on and has several other features which allow flexible control over Beats mode. There are several status modes that determine when Beats will be turned on and which Riff will be used.

Beats and BEAT Triggers can be set to different MIDI channels. This allows you to perform on two MIDI channels at once with a keyboard that only transmits on a single MIDI channel.

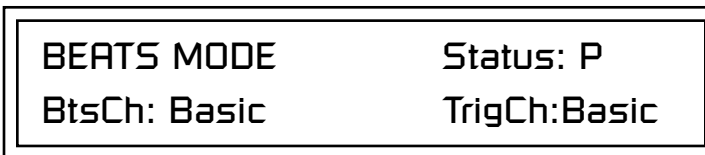

 *The Basic Channel is the MIDI channel currently displayed in the Main Screen.*

### Status

- **Off** . . . . . Beats mode off.
- **On** . . . . . Beats mode on. The Riff assigned in the preset is used.
- **P** . . . . . Beats mode is turned on *ONLY* if the Riff assigned in the preset is a “bts:” riff. The Riff assigned in the preset is used. (*Default setting*)
- **M** . . . . . Beats mode on. The Master Riff is used (Arp/Beats menu).

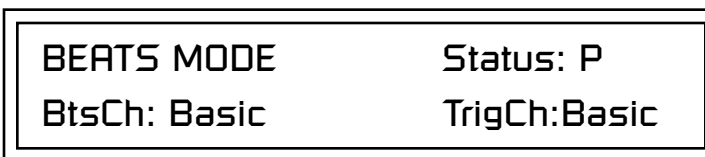

### Beats Channel (BtsCh)

- **01A-16B** . . . Selects the MIDI channel on which Beats play.
- **Basic** . . . . . Beats play on the MIDI channel displayed in the Main Screen.

### Trigger Channel (TrigCh)

- **01A-16B** . . . . . Selects the MIDI channel on which Trigger Keys will be active.
- **Basic** . . . . . Sets the Trigger Keys to the MIDI channel displayed on the Main Screen.



If you don't select a "bts:" preset, only the first trigger key will work.

Riffs marked "bts:" have 16 parts. Riffs without "bts:" have only 1 part.

### ▶ Playing Beats (Quick Start):

1. Press the **right cursor button** twice so that the cursor is located beneath the **Category** field.

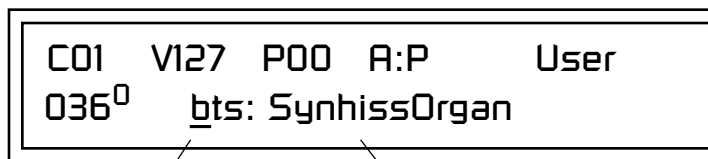

Category Field

Preset Name Field

2. Turn the **data entry control** until **bts:** is shown in the Category field.
3. Press the **right cursor button** so that the cursor is underneath the **Preset Name** field.
4. Now turning the **data entry control** selects ONLY **bts:** presets!

#### Play Beats

5. Play the keyboard keys from C1 to B2.
6. Refer to the "Default Assignment" diagram on page 35 and try out each of the keys.
7. Try out the front panel knobs and other "bts:" presets. *Now check out the other cool BEATS controls explained in this chapter!*
8. **If BEATS are not playing:** Locate the screen at the top of the preceding page in the Arp/Beats menu and set the parameters exactly as shown.

#### Get Busy!

Two of the Controller knobs are programmed to control Beats. Check it out!

9. Select the second row of the front panel Controller knobs. The **E-H LED** will light.
10. Now turn the **Movement** knob with a Beats Riff playing. Movement controls the *Beats Busy* parameter which adds or subtracts parts from the Beat. (*bts: presets only*)
11. Turn the **Rate** knob with a Beats Riff playing. Rate controls the *Beats Variation* parameter. Beats Variation changes which parts are playing without changing the number of parts. This makes it easy to try out different combinations of Beat Part



You can also press the **Audition** button with a *bts:* preset selected to start Beats mode running.

► **To Play Beats on a different MIDI channel:**

Beats can be assigned to a certain MIDI channel while you play the keyboard on another channel. (Make sure you have Beats mode set up correctly as described in "Playing Beats" on page 37.)

1. Press the Arp/Beats button. The screen shown below appears.

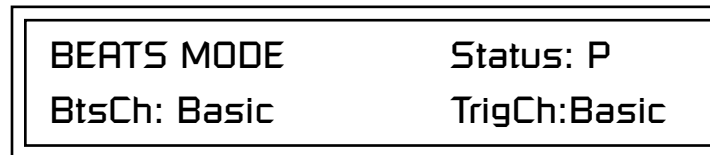

2. Set the Beats Channel (BtsCh) to 01.
3. Select any **bts**: preset on channel 1 (main screen).
4. Press any of the keyboard **Beats Keys** (page 35) to start your Beat.
5. From the main screen, change to channel 2 and select another preset.
6. Select a preset to jam along with the Beat.
7. The Trigger Keys now play Beats and the other keys play the preset on channel 2.
8. The Audition button can be used to turn the Beat off. (If you try to use it to turn Beats on while on channel 2, the Riff on channel 2 will play.)

 **Wrong FX?** In Omni mode, the FX assigned to channel 2 will be used. In Multi mode, the Master FX settings will be used. See pages 68 & 178.

## Beats Controllers

Beats can be controlled using the front panel real-time controllers or external MIDI continuous controllers. **Controllers are patched to Beats via the Preset PatchCords located in the Edit menu.** The following Preset PatchCord destinations control Beats.

### Beat Velocity Group 1-4 (BtsVelG1 -> BtsVelG4)

Parts assigned to one of the four Beats groups can have their velocity scaled by the controller input. Since most "bts" presets have velocity controlling volume, this control can be used to mix the relative levels of the Groups.

Beats velocity works as a percent *addition*. An input value of 0 (or no Cord) means change the velocity by 0%. A full scale modulation setting of 100% in the PatchCord adds 100% to the velocity value  $100\% + 100\% = 200\%$ . A PatchCord setting of -100% *subtracts* 100% from the velocity (making it 0). Beat velocity scalings are reset with a preset change.

### Beat Xpose Group 1-4 (BtsXpsG1 -> BtsXpsG4)

Parts assigned to one of the four Beats groups are transposed by the controller input. Transpose works by shifting the keyboard position and not by changing the tuning of individual notes. Therefore, on a Beats presets (bts), where different instruments are assigned to each key, Transpose has the effect of changing the instrument used by a particular part. This control ADDS to the Part Transpose set in the Beats Transpose screen (page 43). Beat transpose offsets are reset with a preset change.



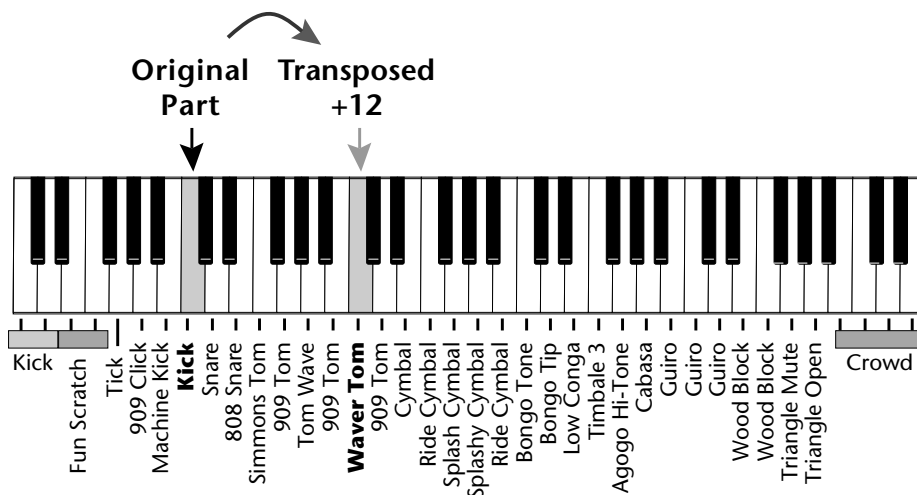

 The Movement controller knob is assigned to Beats Busy.

 A PatchCord amount of 50% is enough to drive Beat Busy to the maximum setting.

 **Hot Tip!**  
**The Bidirectional Mod Wheel:**  
Set Mod Wheel to BtsBusy with a Cord amount of +100, then add a DC bias to BtsBusy with a Cord amount of -50. Wheel now adds or subtracts "Busyness".

### Beat Busy (BtsBusy)

This destination determines which parts are enabled. Beat Busy will accept either positive or negative values.

- **Positive values Add parts to whatever parts are triggered**
- **Negative values Remove parts that are triggered.**

Suppose the pitch wheel (which can output both positive and negative values) were connected to Beat Busy and four Key Triggers are down. As the pitch wheel is moved from center to fully up, the remaining parts will be enabled until the pitch wheel is fully up and all parts are playing. Moving the pitch wheel from center to fully down, the four triggered parts are sequentially removed until at the most negative position of the wheel, no parts are playing.

The Busy control acts on the Beats condition whenever the control is changed. Playing more triggers without changing the Busy control simply adds them until the Busy control is changed again, at which point it will possibly add or subtract parts as needed.

The interaction between the Busy control, Triggers, Part Velocity and Group Velocity can get complicated, but works according to this rule:

### WHICHEVER CONTROL WAS LAST CHANGED TAKES OVER

When interacting with the Group Velocity scale control, the Busy control ignores group velocity even when it is set to zero, enabling and disabling parts as necessary. If the Group Velocity is changed *after* the Busy control, it takes control, scaling parts as it deems necessary.

The Busy control *does* take the Part velocity into account when adding and subtracting parts. If a part has a velocity of 0%, it is removed from the list of

 **Cool Tip!** Connecting Key Pressure to Beat Busy at 50% increases BEAT complexity the harder you press.

parts that the Busy control adds or subtracts. Therefore, you can use the Part Velocity control to remove parts you don't want to hear.

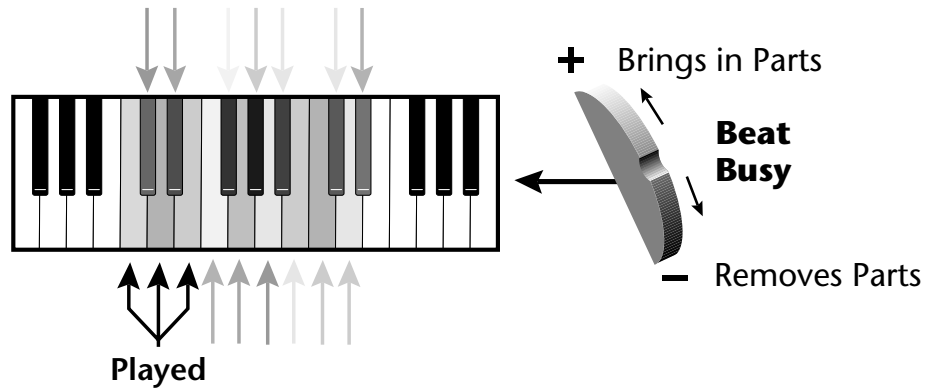

Positive controller values bring in new Parts and negative controller values remove Parts that are latched or held. In this example, the Pitch Wheel is connected to Beat Busy since it outputs negative as well as positive values.

 The Rate controller knob is assigned to Beats Variation.

### Beat Variation (BtsVari)

Beat Variation varies which Parts are brought in and out using the Beat Busy control. Increasing this control mixes up the order in which Parts are brought in and out, thus providing even more permutations to the Beat.

## Beats Keys Layout

This screen assigns the Beats triggers to keyboard notes on the Beats channel. For each Part, Group and Control Key you can select the following options:

 Save your Beats Keys Layouts and all other Arp/Beats parameters using "Save Setup" function in the Save/Copy menu.

- **Key** . . . . . Selects which keyboard key triggers the Part
- **Latch** . . . . . The first key press turns the Part on, the next turns it off.
- **Unlatch** . . . . . The Part plays only while the key is held.
- **1-bar** . . . . . The Part plays for one bar then stops.

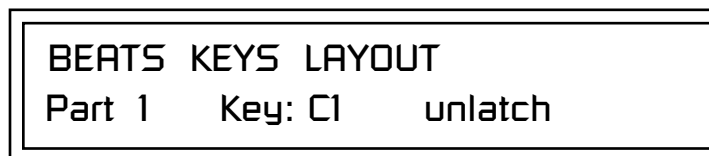

### 1-Bar Trigger Option

The 1-bar option requires a bit of explanation. When a trigger key is pressed before the last beat of the measure, the part will continue playing until the end of the measure. If the Trigger Key is pressed after the last beat of the measure, the part waits until the next measure before playing. Then it plays

for the entire measure and stops. The time signature and the measure bounds are determined by the particular Beats Riff you are playing.

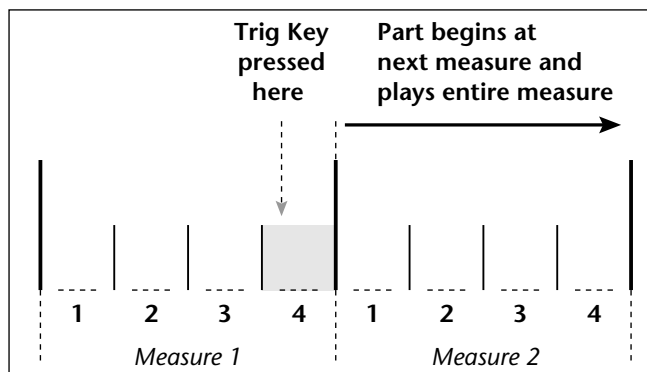
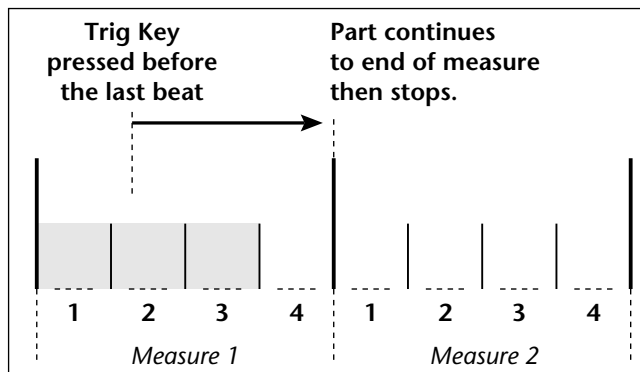

### Beats Keys Offset

This function slides the Beats Trigger keys (assigned in the previous screen) up and down the keyboard. This makes it easy to change the keyboard location of the trigger keys without having to re-assign each key. A positive offset moves the group of triggers up the keyboard by the designated number of keys. Negative offsets move the trigger group lower on the keyboard.

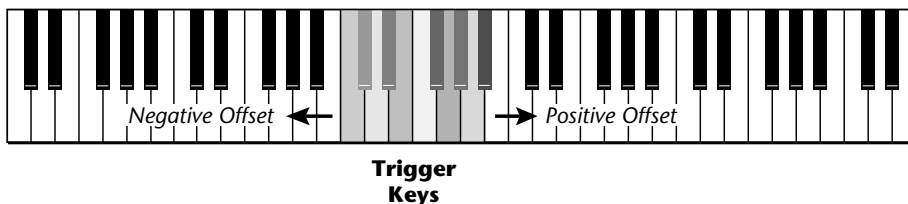

Beats Keys Offset slides the entire group of beats triggers up or down the keyboard.

## Beats Part Velocity

Each note of a Beats Riff can have its recorded velocity scaled by a value (from 0 to 120%) of the recorded velocity or the actual played velocity of the trigger key can be used (trigger vel). For example, if a note's velocity is 80, scaling by 110% will increase the note's velocity to 88. This feature allows you to control the mix of the different parts in advance or "on-the-fly" as you play. If a part's velocity is set to 0%, that part will be removed from the mix.

Select Part

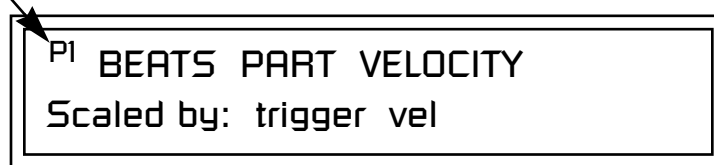

### ► To Set the Velocity for each Part:

1. Press the left cursor button to move the cursor under the Part field.
2. Select the Part number using the Data Entry Control. Parts 1-16 can be selected. *(All parts, shown as an "A", can be edited at once if "Edit All Layers" is enabled in the Master menu.)*
3. Move the cursor to the bottom line using the cursor keys and adjust the Velocity Scaling percentage using the Data Entry Control.
4. Repeat steps 1 through 3 for all the Parts you wish to adjust.
5. Press the Enter/Home button or use the cursor keys to move the cursor back to the screen heading.

## Beats Part Transpose

Each Part of a Beat Riff can be transposed up to 36 semitones up or down. Transpose works by shifting the keyboard position and not by changing the tuning of individual notes. Therefore, on a Beats preset (bts:), where different instruments are assigned to each key, **Transpose has the effect of changing the instrument used by a particular part.** On a preset where a single sound covers the entire keyboard, Transpose will actually transpose the sound.

Select Part



### ► To set the Transposition for each Part:

1. Press the left cursor button to move the cursor under the Part field.
2. Select the Part number using the Data Entry Control. Parts 1-16 can be selected. (All parts, shown as an "A", can be edited at once if "Edit All Layers" is enabled in the Master menu.)
3. Move the cursor to the bottom line using the cursor keys and adjust the Transposition in semitones using the Data Entry Control.
4. Repeat steps 1 through 3 for all the Parts you wish to adjust.
5. Press the Enter/Home button or use the cursor keys to move the cursor back to the screen heading.

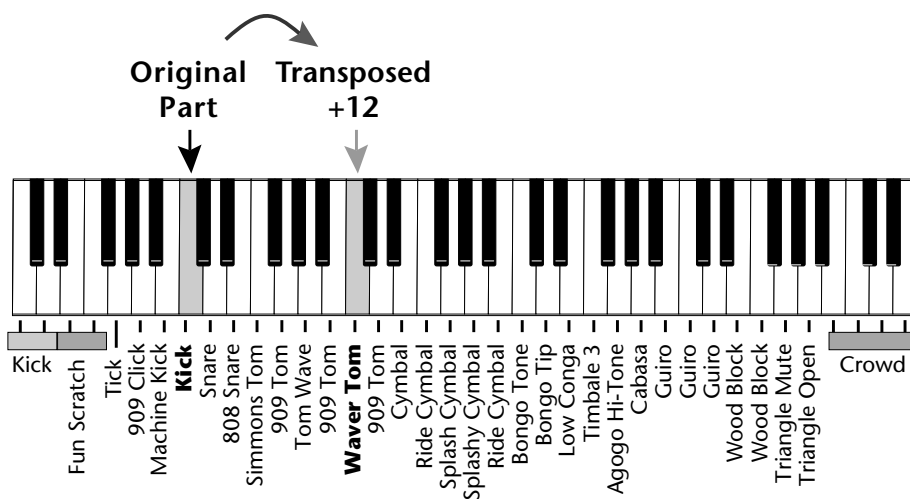

## Beats Part Group

This screen is where you assign Parts to one of the four Groups. By grouping, you can play multiple parts with a single key. A part can be in one and only one group, or in no groups.

Select Part

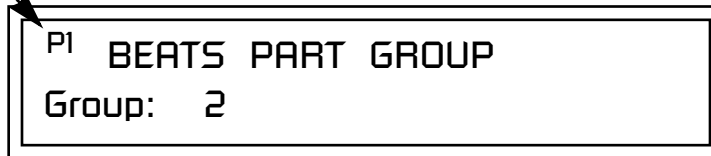

*All Parts assigned to a Group will stop playing when the Group key is triggered, then untriggered even if the individual Parts in the Group are latched.*

### ► To Assign a Part to a Group:

1. Press the left cursor button to move the cursor under the Part field.
2. Select the Part number using the Data Entry Control. Parts 1-16 can be selected. (All parts, shown as an "A", can be edited at once if "Edit All Layers" is enabled in the Master menu.)
3. Move the cursor to the bottom line using the cursor keys and select the Group (1-4 or none) using the Data Entry Control.
4. Repeat steps 1 through 3 for all the Parts you wish to assign.
5. Press the Enter/Home button or use the cursor keys to move the cursor back to the screen heading.

## Master Riff

The Master Riff is selected from this screen. The Master Riff is used when Master (M) is selected for Beats in Beats mode enable screen.



### ► To Assign the Master Riff:

1. Use the cursor buttons to move the cursor to the lower line of the display.
2. Select the desired Riff using the Data Entry Control. (Beats Riffs are identified by the **bts:** prefix.)
3. If there is more than one ROM in Vintage Pro you can select Riffs from either ROM set. Move the cursor under the ROM ID and select using the Data Entry Control.
4. Press the Enter/Home button or use the cursor keys to move the cursor back to the screen heading.

## Riff Tempo

This setting determines whether **Riff Tempo** (the tempo stored with each Riff) or the **Current Tempo** (the Base Tempo from the Master Clock) will be used for Beats.

To control the Riff Tempo from MIDI clock, set Riff Tempo to “use current tempo” and Base Tempo to “use MIDI”.

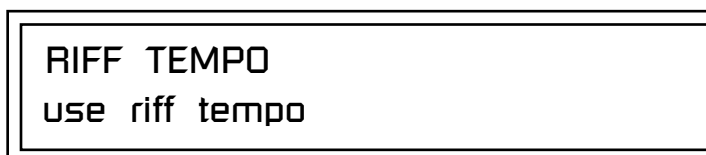

### ► To Set the Riff Tempo Mode:

1. Use the cursor buttons to move the cursor to the lower line of the display.
2. Select “use riff tempo” or “use current tempo” using the Data Entry Control.
3. Press the Enter/Home button or use the cursor keys to move the cursor back to the screen heading.

## Riff Controllers

Riffs contain real-time control information. This function allows you to turn these controllers On or Off for the Riffs. This control affects Audition Riffs as well as Beats Riffs.



### ► To Turn Riff Controllers On or Off:

1. Use the cursor buttons to move the cursor to the lower line of the display.
2. Select “use riff controllers” or “ignore riff controllers” using the Data Entry Control.
3. Press the Enter/Home button or use the cursor keys to move the cursor back to the screen heading.

### *MIDI Song Start*

This function enables or disables MIDI Song Start for the Arpeggiator and Riffs. The MIDI Song Start option restarts the arpeggiator and/or Riff (BEAT) to the beginning when a MIDI Song Start command is received. This is useful for synchronizing arpeggios and Beats when recording into, or playing along with a sequencer. You can choose to resync: Arp, Riff, both Arp and Riff, or disable MIDI Song Start.

**MIDI SONG START**  
resyncs arps & riffs

### *Arp/Riff MIDI Out*

This parameter selects whether or not the Arpeggiator and/or Riff (Beats) note data is sent to the MIDI out port. This feature lets you use Vintage Pro as an arpeggiator or sequencer for your other MIDI instruments. It also lets you record the arpeggios and Riffs into a MIDI sequencer. You can choose to transmit: Arpeggiator data, Riff data, both Arp and Riff data, or nothing.

**ARP/RIFF MIDI OUT**  
don't transmit



## Arpeggiators

An arpeggiator moves a pattern of notes sequentially over a range of the keyboard. Vintage Pro has the unique ability to play a different arpeggiator on each MIDI channel!

Arpeggiator settings can be defined as part of the preset (using the Arp parameters in the Preset Edit menu), or globally in the Arpeggiator menu. The preset and master arpeggiators have the same parameters which we define in this chapter.

The Arp field in the main screen defines which arpeggiator settings will be used. "M" uses the master Arpeggiator settings and on/off status (as defined in the Arpeggiator menu). "P" uses the preset's arpeggiator settings and on/off status (as defined in the Edit menu). Choosing "On" uses the preset's arpeggiator settings regardless of whether or not it is turned on in the Edit menu and Off turns off the arpeggiator regardless of the settings and status specified in either menu.



**SAVE your Arp setups**  
and name them using the "Save Setup To" function located in the **Multi** menu. See "Saving Multisetups" on page 193.

Arp Settings in the  
Preset are Used

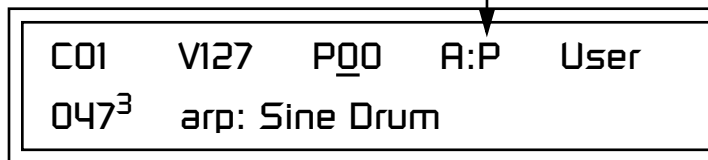

All arpeggiators share Vintage Pro's master clock and its current setting. The master clock can be Vintage Pro's internal clock or an external MIDI clock (page 33). Although the arpeggiators use the master clock setting, the tempo divisor can be unique for each arpeggiator setup.

Arpeggiator modes include up, up/down, forward assign, backward assign, forward/backward assign and random as well as play *Patterns*. Patterns are pre-recorded sequences of notes and rests. All key-on notes play the pattern. For example, if you play a chord, all the notes in the chord play the pattern in harmony. Vintage Pro contains 300 factory patterns and 100 user definable patterns.

## Arp Controllers

The Arpeggiators can be controlled using the front panel real-time controllers or external MIDI continuous controllers. Controllers are patched to Arps via the Preset PatchCords located in the Preset Edit menu. See “Preset Patchcords” on page 151. The following Preset PatchCord destinations control the Arpeggiators.

### Arpeggiator Resolution (ArpRes)

This control changes the Arpeggiator Note Value, which defines the length of the notes when playing arpeggiated chords. It *adds* to the note value set in the Arpeggiator Note Value screen. See “Note Value” on page 50.

### Arpeggiator Extension (ArpExt)

This control changes the Arpeggiator Extension Count. It *adds* to the extension count programmed in the Arpeggiator Note Value screen. See “Extension Count” on page 52.

### Arpeggiator Velocity (ArpVel)

This control changes the Arpeggiator Velocity Value. It *scales* the velocity value set in the Arpeggiator Note Value screen. See “Velocity” on page 51.

### Arpeggiator Gate (ArpGate)

This control changes the Arpeggiator Gate Time. It *adds* to the gate time set in the Arpeggiator Gate Time screen. See “Gate Time” on page 51.

### Arpeggiator Interval (ArpIntvl)

This control modulates the Arpeggiator Extension Interval. It *adds* to the extension programmed in the Arpeggiator Extension Interval screen. See “Extension Interval” on page 52.

The Master Arpeggiator is defined in the Arp menu. The Arpeggiator mode selected on the Main Screen determines whether the Master arpeggiator or the Preset menu arpeggiator settings are used.

#### ► To Access the Master Arpeggiator Parameters:

1. Press the **Arp/Beats** menu button lighting the LED. The Arpeggiator menu screen displays the menu page most recently selected since powering up Vintage Pro. The cursor appears below the first character of the screen heading on line one.
2. Use the right **cursor** button to advance the cursor to the first field in the bottom line of the screen.
3. Now, use the **data entry control** to access the various Master Arpeggiator parameters.
4. **Save** your Arpeggiator settings using the “Save Setup” function on the Multi menu. See page 193.

## Master Arpeggiator Parameters

## Status

The Status parameter turns the Master Arpeggiator on and off. The Channel Arpeggiator setting in the main screen overrides this setting. For example, if you set the Arpeggiator in the main screen to “off,” and turn it “on” here, it still will not play.



## Mode

The Mode parameter determines the direction or pattern mode of the arpeggiated notes.

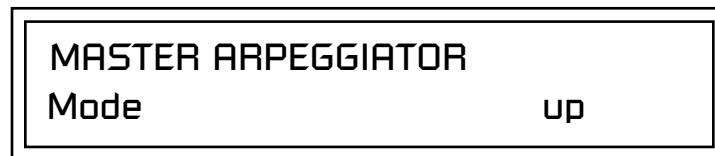

The eight arpeggiator modes are:

- **Up** Held notes arpeggiate continuously from lowest to highest pitch.
- **Down** Held notes arpeggiate continuously from highest to lowest pitch.
- **Up/Down** Held notes arpeggiate continuously from lowest to highest pitch, then from highest to lowest, then repeat this cycle.
- **Fwd Assign** Held notes arpeggiate continuously in the order in which the keys were pressed.
- **Bkwd Assign** Held notes arpeggiate continuously in the reverse order in which the keys were pressed.
- **Fwd/Bkwd** Held notes arpeggiate continuously in the order in which the keys were pressed, then arpeggiate in the reverse order that they were pressed. The cycle is then repeated.
- **Random** Held notes arpeggiate continuously in a random fashion.
- **Pattern** Held notes play the selected pattern (see “Pattern” on page 50 for details).

## Note Value

The Note Value determines the duration of each note played. This parameter is used in non-pattern mode only.

|                           |         |
|---------------------------|---------|
| <b>MASTER ARPEGGIATOR</b> |         |
| Note Value                | 1/8 dot |

Following is a list of possible Note Values and the relative number of clocks used for each.

 Note value has no effect when the mode is set to "pattern."

| Note Value                     | MIDI Clock |
|--------------------------------|------------|
| <b>Double Whole Note</b> ..... | 192        |
| Dotted Whole Note .....        | 144        |
| Double Note Triplet.....       | 128        |
| <b>Whole Note</b> .....        | 96         |
| Dotted Half Note .....         | 72         |
| Whole Note Triplet.....        | 64         |
| <b>Half Note</b> .....         | 48         |
| Dotted Quarter Note .....      | 36         |
| Half Note Triplet.....         | 32         |
| <b>Quarter Note</b> .....      | 24         |
| Dotted Eighth Note .....       | 18         |
| Quarter Note Triplet .....     | 16         |
| <b>8th Note</b> .....          | 12         |
| Dotted 16th Note .....         | 9          |
| 8th Note Triplet.....          | 8          |
| <b>16th Note</b> .....         | 6          |
| Dotted 32nd Note .....         | 4.5        |
| 16th Note Triplet.....         | 4          |
| <b>32nd Note</b> .....         | 3          |

## Arpeggiator Pattern Speed

The Arpeggiator Pattern Speed parameter lets you change the playback rate of Patterns by 1/4x, 1/2x, 1x (normal), 2x or 4x normal speed.

## Pattern

This field lets you choose the pattern used when the arpeggiator Mode is set to "Pattern." There are 200 factory programmed patterns and you can create an additional 100 user definable patterns (see "Editing a User Arpeggiator Pattern" on page 57).

|                           |                              |
|---------------------------|------------------------------|
| <b>MASTER ARPEGGIATOR</b> |                              |
| Pattern                   | 99 <sup>1</sup> Pattern Name |

## Velocity

 Controller Knob 0 is programmed to control Arp Velocity.

The Velocity parameter determines the velocity at which each note arpeggiates. Velocity can be defined by the velocity value specified (from 1 through 127), or by the actual velocity of the played note (played). Bear in mind that velocity values do not have an effect on the sound unless the preset is programmed to respond to velocity.

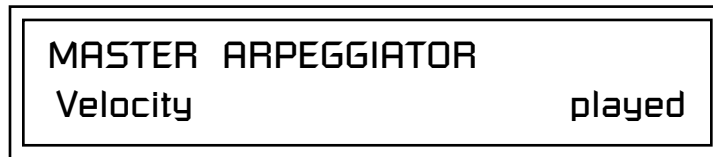

## Gate Time

 The Movement Knob is programmed to control Arp Gate Time.

The Gate Time parameter works together with the Note Value parameter. Just as Note Value defines the length of a note, the Gate Time sets the percentage of the Note Value time played. This can have a dramatic effect on the sound depending on how the envelope generators are programmed.

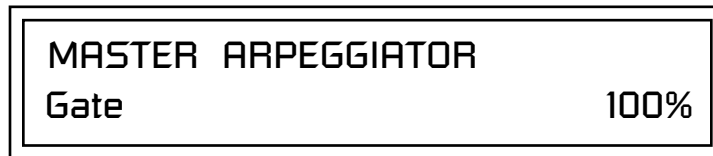

 The **note-on** time is used for the start-of-time when calculating note durations. See "Duration" on page 54.

With a Gate Time setting of 100% the note is held on until the next note starts. The envelope generators never advance to the Release stages. With a Gate Time setting of 50%, the note is released halfway through the note cycle and the envelope generators proceed to their release stages until the next note occurs. Refer to the following illustration.

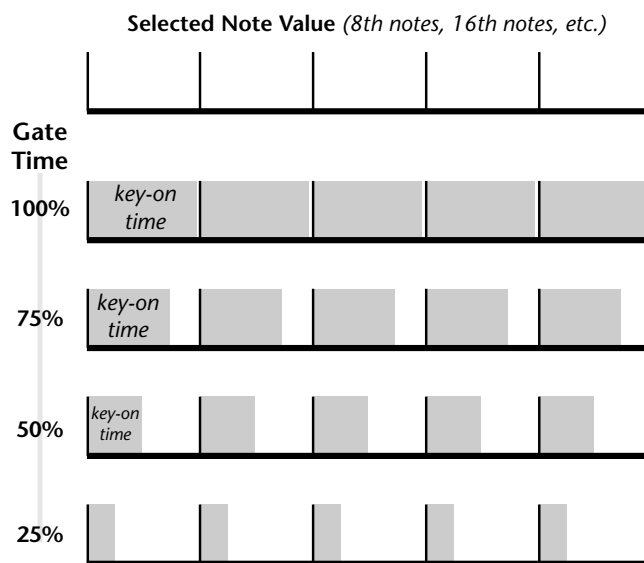

## Extension Count

The Extension Count parameter specifies how many times the Extension Interval is carried out. With an Extension Count of 0, the arpeggio plays only the notes pressed. With an Extension Count of 1, the arpeggio plays the notes pressed, then plays the same notes (in the same order), transposed by the Extension Interval amount. The cycle is then repeated.



For example, with the Extension Interval set to 12 (an octave) and an Extension Count of 2, and with the Arpeggiator Mode set to Fwd Assign, if you played E2, then C2, then G2, the arpeggiated sequence would consist of: E2, C2, G2, then E3, C3, G3, and then E4, C4, G4. The Extension Count values range from 0 through 15. Refer to the following illustration.

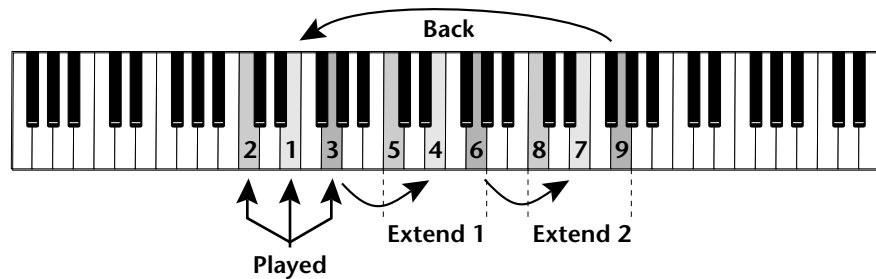

## Extension Interval

The Extension Interval specifies the additional intervals played when you press a key. For example, suppose you played C2 with an Interval of 7 (a Major 5th), Up mode, and an Extension Count of 2. The arpeggio alternates between C2 and G2.

The Extension Interval values range from 1 through 16.

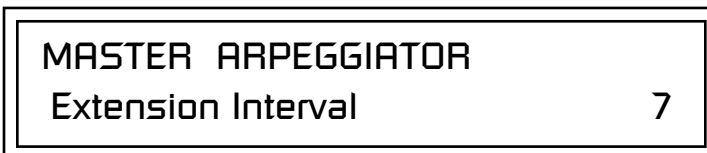

## Sync

The Sync parameter defines when a note is played in relation to when the key is pressed. When set to “Key Sync”, the note sounds the instant a key is pressed. When set to “Quantized”, the note does not sound until the next occurrence of the selected note value.

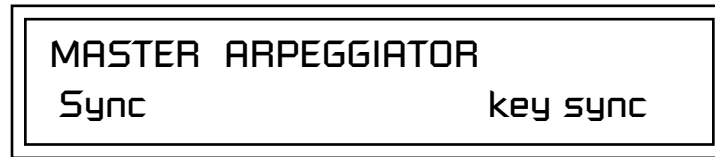

The following diagram illustrates how Key Sync and Quantize work.

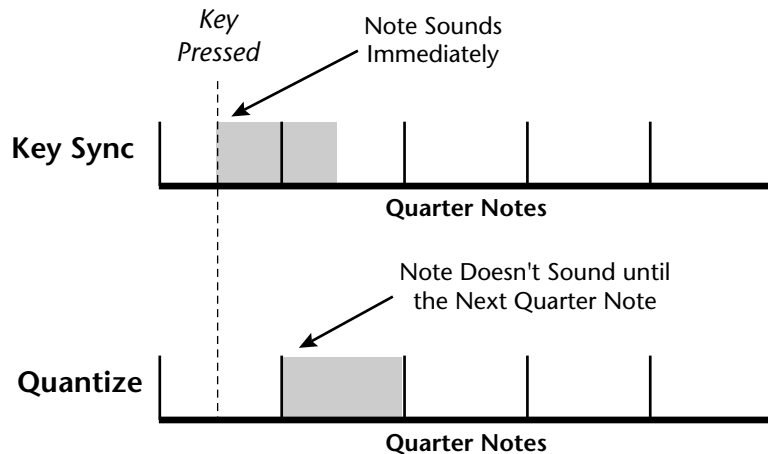

## Pre-Delay

The Pre-Delay value determines how long the arpeggiator is delayed before becoming active after the first “note-on.” During the pre-delay period, notes are played normally (as if the arpeggiator was off). After the pre-delay period has elapsed, the arpeggiator kicks in. Once you release all the keys on the controller, the pre-delay starts over with the next note-on. In combination with the Duration parameter, Pre-Delay lets you create many more variations in the arpeggio patterns. *Please refer to the diagram on page 55.*

You can play the preset normally as long as you don't hold the notes longer than the Pre-Delay. If you do, the arpeggiator starts in. When used in conjunction with multiple arpeggiators, Pre-Delay allows you to offset the time between the different patterns.

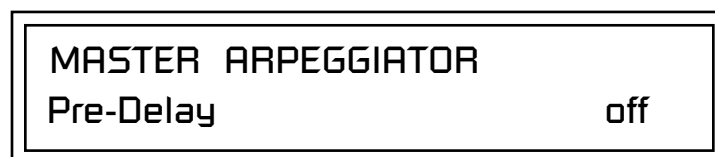

## Duration

This parameter defines how long the arpeggiator plays before stopping. The Duration is specified in note values. Therefore if an arpeggio were running at a 16th *Note Value* and the Duration were set to a whole note, the arpeggiator would play 16 steps before stopping. After the duration has elapsed, the arpeggiator remains inactive until the key is released. If Duration is set to Off, the arpeggio repeats as long as the notes are held (Infinite Duration).

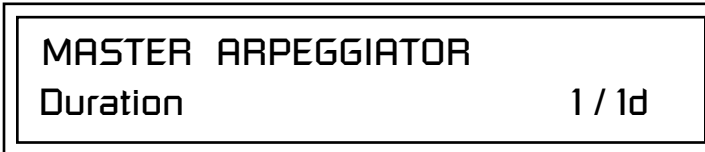

Duration can be used to modify the patterns and increase the possible pattern combinations and variations. Because this parameter limits the length of arpeggiator play time, it can change the arpeggio pattern when the Duration is less than the length of the arpeggio. You can set the arpeggio to repeat continuously using the *Recycle* function described below.

## Post-Delay

This parameter is only relevant when both the "Duration" and "Recycle" parameters are not in the "Off" state. The Post-Delay value determines how long the arpeggiator is delayed after the Duration period. *Please refer to the diagram on page 55.* During the post-delay period, notes are played normally (as if the arpeggiator was off). After the post-delay period has elapsed, the arpeggiator either jumps to the beginning of the Pre-Delay period or to the beginning of the Duration period depending on the Recycle setting.

If the arpeggiator is playing an extension when the Duration expires, the notes in the extension will continue to sound during the Post-Delay (*and Pre-Delay if on*). On the next pass through the Duration period, the extension continues where it left off.

Post-Delay increases the number of possible variations in the beat and allows the recycle loop to be set to an exact measure of time.

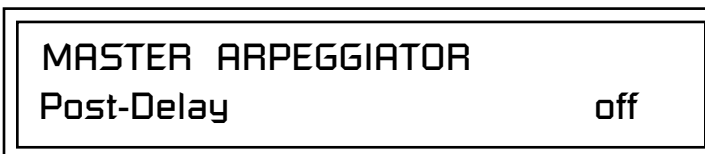



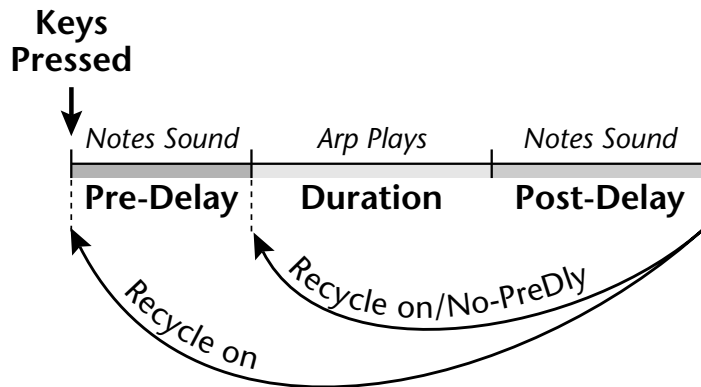

*Recycle*

Recycle enables the pattern or arpeggio to repeat. This parameter works together with the *Duration* and *Pre/Post Delay* parameters to allow the loop to be set to an exact measure of time. The “on/No-PreDelay” option bypasses the predelay period. With Recycle turned Off, the pattern or arpeggio stops at the end of the Post-Delay period.

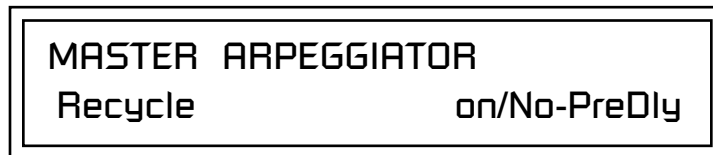

*Keyboard Thru*

When enabled, Keyboard Thru merges the notes not arpeggiated with the notes being produced by the arpeggiator. This gives the effect of two parts playing at once.

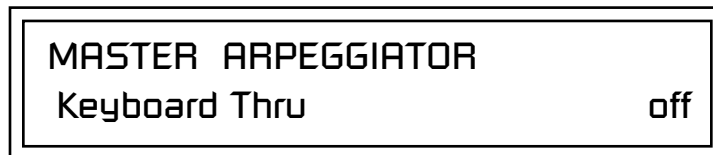

*Latch*

With Latch mode On, any notes you play remain on until you press them again. Latched notes can also be halted by turning Latch off in this screen, or by turning off the Arpeggiator for the channel in the main screen.

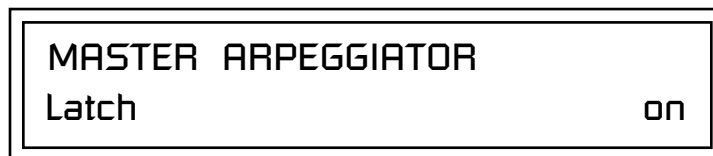

Use the Key Range parameter to set the keyboard range for the arpeggiator. Notes inside the range will arpeggiate while notes outside the specified range will not arpeggiate. Use the Extensions parameters to exceed the upper boundary of the Key Range (see the information about Extensions beginning on page 52).

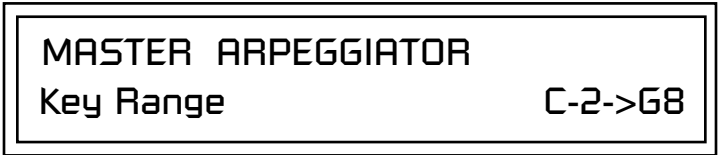

Move the cursor under the first key and use the data entry control to define the lowest key to be arpeggiated. Move the cursor under the second key value and use the data entry control to define the highest key to be arpeggiated.

Transmits the Arpeggiator Patterns via the MIDI out port as MIDI System Exclusive data to another Vintage Pro or to a computer/sequencer for backup. Using the cursor key and the data entry control, select the MIDI data you want to transmit. See *Send MIDI System Exclusive Data* in the Master chapter for additional details about recording SysEx.

#### User Patterns

Transmits all the User patterns.

#### 00<sup>0</sup> to 99<sup>0</sup>

Transmits only the individual pattern you have selected.

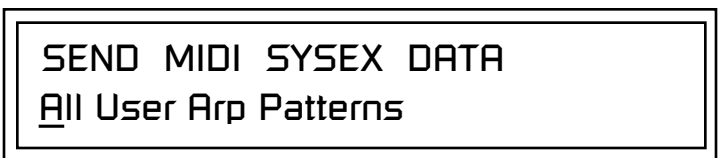

## Send MIDI System Exclusive Data



*Send data as you would a regular sequence. Sending data in one huge chunk may clog the MIDI input buffer on Vintage Pro.*

## Editing a User Arpeggiator Pattern

**Bank 0 User** = User Patterns  
**Bank 0** = Factory Patterns  
**Bank 1** = Factory Patterns  
**Bank 2** = Factory Patterns

 Before editing a Pattern, select Master Arpeggiator (M) in the main screen and set the Arpeggiator to the Pattern you are editing. This lets you hear the Pattern as you edit it.

Vintage Pro lets you create and edit your own arpeggiator patterns. Using the Edit User Pattern menu, you can create up to 100 user patterns and each pattern can be up to 32 steps in length.

When you edit a pattern, you are writing directly into memory—no Save command is required (however, you must exit the Arp module). This is different from the Edit menu where you must Save a preset before it will be overwritten. If you want to modify an existing pattern and keep the original, you must first COPY the pattern you want to edit to another location using the function in the Save/Copy menu (See page 191). Refer to the instructions below and the following parameter descriptions to create your own patterns.

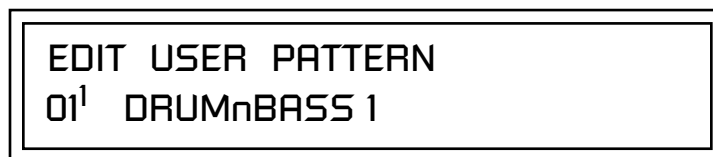

### ► To Select the Pattern to Edit:

1. From the Edit User Pattern screen shown above, move the cursor to the bottom line and **select the pattern** you want to edit. The Enter LED begins flashing. Press **Enter** to move back to the Home position.
2. Select the **next screen** in the list, "User Pattern Edit". This is where you edit the currently selected pattern.

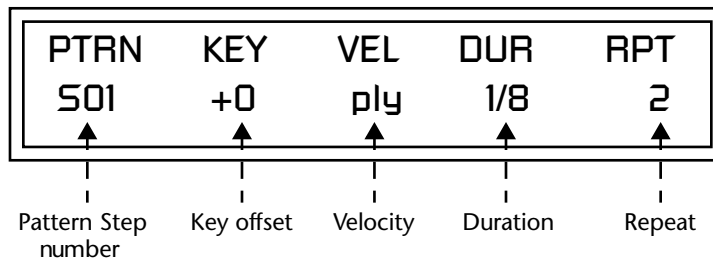

3. Move the cursor to the **lower line** of the display. For each step, you can select: key, velocity, duration, and number of repeats.

## Pattern Step Number

You can set up to 32 steps for each arpeggiator pattern. This field selects which step you will be editing from 1 to 32.

## Key

This parameter defines what happens during the current step. The Key parameter can do one of five different operations. Following is a description of each of the key functions and how to use them.

### Key Offset

This parameter defines not the actual note of the arpeggiator playback, but instead specifies the amount of offset, in semitones, from the original note played. You can set a Key Offset from -48 to +48 for each step. For example, if you play a "C" on the keyboard with the Key Offset amount for the first step set to "+1," the first step in the pattern will be "C#."

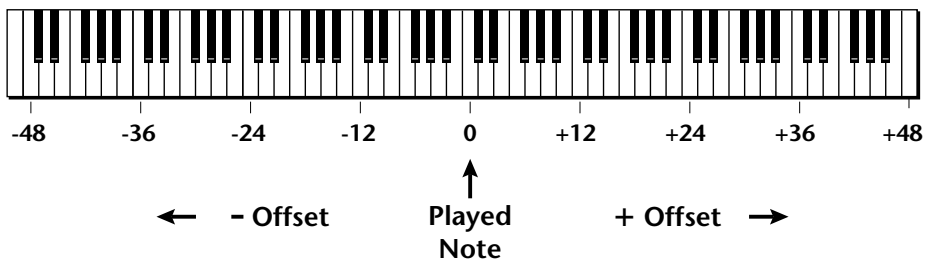

### Tie

This function *extends* the duration of notes beyond the values given in the duration field by "tying" notes together. You can tie together any number of consecutive steps.

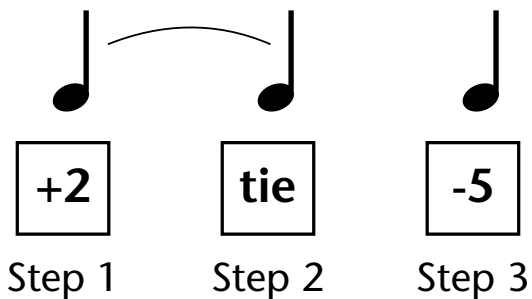

### Rest

Instead of playing a note, you can define the step as a Rest. The Duration parameter specifies the length of the rest. Rests can be tied together to form longer rests.

### Skip

This command simply removes the step from the pattern. The Skip feature makes it easy to remove an unwanted step without rearranging the entire pattern. You'll be happy to know that the velocity, duration and repeat parameters are remembered if you decide to put the step back later.

### End

This command signals the end of the pattern. Any steps programmed after the step containing the End command are ignored.



**IMPORTANT:** The Gate function in the arpeggiator *MUST* be set to 100% when using the tie function, otherwise the tied note is retriggered instead of extended.

## Velocity

Each note in the pattern plays using either a preset velocity value (from 1 through 127), or using the actual velocity of the played note (ply).

**Note:** Velocity values will not have an effect on the sound unless velocity is programmed to do something in the preset.

## Duration

This parameter sets the length of time for the current step, defined as a note value, based on the Master Tempo. The selectable note durations are described below.

|       |                      |      |                           |
|-------|----------------------|------|---------------------------|
| 1/32  | 32nd Note            | 1/2t | Half Note Triplet         |
| 1/16t | 16th Note Triplet    | 1/4d | Dotted Quarter Note       |
| 1/32d | Dotted 32nd Note     | 1/2  | Half Note                 |
| 1/16  | 16th Note            | 1/1d | Dotted Whole Note         |
| 1/8t  | 8th Note Triplet     | 1/1t | Whole Note Triplet        |
| 1/16d | Dotted 16th Note     | 1/2d | Dotted Half Note          |
| 1/8   | 8th Note             | 1/1  | Whole Note                |
| 1/4t  | Quarter Note Triplet | 2/1t | Double Whole Note Triplet |
| 1/8d  | Dotted Eighth Note   | 2/1  | Double Whole Note         |
| 1/4   | Quarter Note         |      |                           |

## Repeat

Each step can be played from 1 to 32 times. A repeat setting of "1" indicates the step will be played one time (not repeated one time or played twice).

### ► To Edit a User Pattern:

1. The first field in the Edit User Pattern field defines the pattern's step number. Start with the pattern Step 01.
2. Define the Key Offset, Velocity, Duration and Repeat values.
3. Repeat steps 1 and 2 until you have setup the desired number of steps in the pattern.
4. Set the Key Offset to "End" on the last step in the pattern.

## User Pattern Name

The User Pattern Name page lets you enter a name for any User Arpeggiator Pattern.

|              |     |     |     |     |
|--------------|-----|-----|-----|-----|
| <u>P</u> TRN | KEY | VEL | DUR | RPT |
| S01          | +0  | ply | 1/8 | 2   |

### ► To Name a User Pattern:

1. From the Pattern Edit screen shown above, position the cursor under the **PTRN** field.
2. Turn the **data entry control** clockwise. The following screen appears.

|                           |
|---------------------------|
| <u>U</u> SER PATTERN NAME |
| 00 <sup>0</sup> Mod Cycle |

3. Move the cursor to the bottom line and **edit the Pattern** name using the data entry control and Cursor keys.
4. Move the cursor to the “**Home**” position (shown above) by pressing the **Home/Enter** button.
5. Turn the **data entry control** counter-clockwise one click to return to the Pattern Edit screen.
6. Turn the **data entry control** counterclockwise multiple clicks to jump back to the main Arpeggiator menu screen.

## Multi-Channel Arpeggiating

One of the coolest features in Vintage Pro is its ability to run multiple arpeggiators at the same time. The interactions of multiple note sequences can be complex and fascinating. Vintage Pro lets you run up to sixteen arpeggiator patterns at once! Even two or three patterns at once can create very complex sequences and dynamic landscapes of sound.

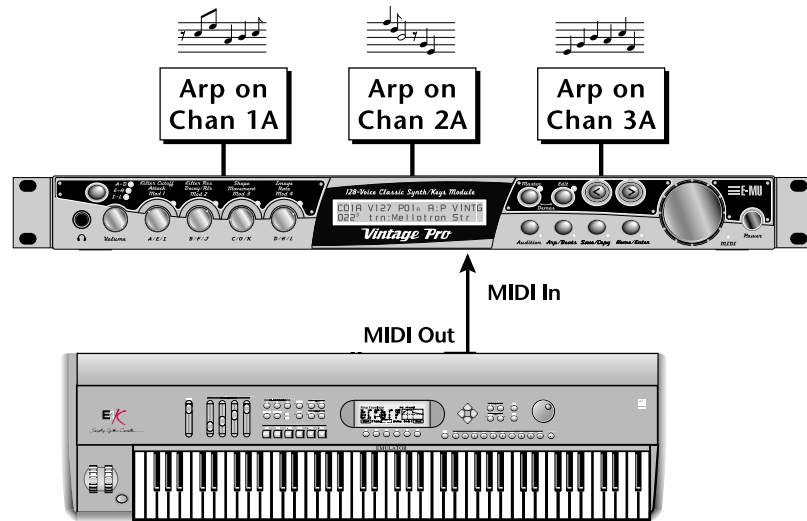

Master Keyboard transmitting on  
MIDI channels 1, 2, 3

Here's one way to use this ultra-powerful feature. There is one arpeggiator for each MIDI channel. In order to arpeggiate on multiple channels, you need a controller that can output multiple MIDI channels at once.

1. Set up your MIDI keyboard so that it outputs the entire keyboard on MIDI channels 1 and 2. This procedure varies with the type of keyboard you own. Refer to the owner's manual that came with your keyboard for instructions.
2. Put Vintage Pro into Multi mode. This is located in the Master menu, MIDI Mode page.
3. On the main screen, turn the arpeggiator "on" for MIDI channels 1 and 2. (We're only using two channels for now to keep it simple.) Select a different preset for each MIDI channel while you're at it.

|                  |                 |     |      |      |
|------------------|-----------------|-----|------|------|
| C01              | V127            | P00 | A:on | VROM |
| 039 <sup>1</sup> | syn: Juno Pulse |     |      |      |

4. Start playing. You should be hearing two arpeggiators playing at once.

Try experimenting with presets and settings. For example:

- Change presets on one or both of the MIDI channels you are using (1 & 2). Since each factory preset has different arpeggiator settings, changing the preset not only changes the sound, but the arpeggiator settings as well.
- Press the Control button on the front panel to select “I-L” (the LED in the third row is illuminated). Adjust the front panel control knobs. These knobs usually control the arpeggiator on presets with the “arp:” prefix.
- Try changing one of the channel’s arpeggiator setting to “M” instead of “on.” Now press the Arpeggiator Menu button and adjust the arpeggiator parameters in real time.
- From the Master Arpeggiator menu, set the Mode to Pattern then explore the different patterns. There are 300 patterns available!

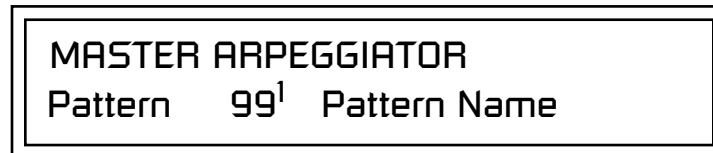

Now you’re getting the picture. This machine is beyond awesome!

## Using a MIDI Interface to Channelize Data

Not all keyboards or controllers can transmit on multiple MIDI channels at once. If your MIDI controller only transmits on a single MIDI channel, there are other ways to use the multi-channel arpeggiators. A MIDI interface such as Mark of the Unicorn’s MIDI Time Piece®, or a MIDI router box will convert data on one channel to any other channel or channels.

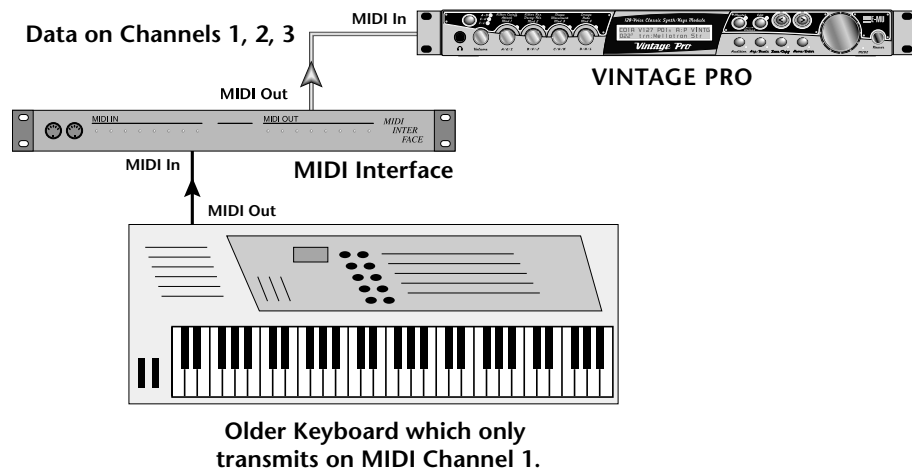

Your MIDI Interface may be able to output MIDI data on multiple channels at once.



# Master Menu

The Master menu contains functions that affect the overall operation of Vintage Pro. For example, changing the Master Tune parameter changes the tuning of all the presets, not just the one currently displayed.

▶ **To enable the Master menu**

Press the Master button, lighting the LED. The Master Menu screen displays the menu page most recently selected since powering up Vintage Pro. The cursor appears below the first character of the screen heading on line one.



**Warning:** Master Menu changes are automatically saved when you exit the module. If the power is turned off before you exit the module any changes you have made will be lost.

▶ **To select a new screen**

Press the Home/Enter button or press the Cursor button repeatedly until the cursor is below the screen title heading. Rotate the Data Entry Control to select another screen.

▶ **To modify a parameter**

Press either Cursor button repeatedly (or hold down the right cursor button while turning the Data Entry Control) until the cursor is below the desired parameter value. Rotate the Data Entry Control to change the value.

▶ **To return to the main screen**

Press the Master button, turning off the LED.

## Defining Master Parameters

### *Transpose/Tune*

Master setup parameters affect overall performance, range, and global effects. This section describes the Master parameters and how to define them.

The Transpose parameter transposes the key of all presets, in semitone intervals. The transpose range is  $\pm 24$  semitones.

Master Tune adjusts the fine tuning of all presets so that you can tune Vintage Pro to other instruments. The master tuning range is  $\pm 1$  semitone in 1/64th semitone increments (1.56 cents). A master tune setting of "+00" indicates that Vintage Pro is perfectly tuned to concert pitch (A=440 Hz).

|                         |             |
|-------------------------|-------------|
| <b>MASTER TRANSPOSE</b> | <b>TUNE</b> |
| <b>+00 semitones</b>    | <b>+00</b>  |

### *Bend Range*

The Bend Range parameter sets the range of the pitch wheel. This affects only presets that have their individual Pitch Bend range (defined in the Edit menu) set to Master. The maximum pitch bend range is  $\pm 12$  semitones or one octave in each direction.

|                          |
|--------------------------|
| <b>MASTER BEND RANGE</b> |
| <b>+/- 7 semitones</b>   |

## Velocity Curve

You can modify incoming velocity data by a velocity curve in order to provide different types of dynamics in response to your playing, or to better adapt to a MIDI controller. The Master Velocity Curve page lets you select one of thirteen master velocity curves or to leave the data unaltered (linear).

### MASTER VELOCITY CURVE 13

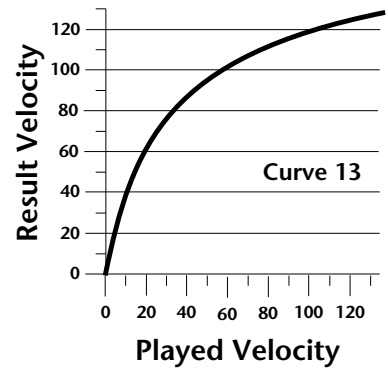
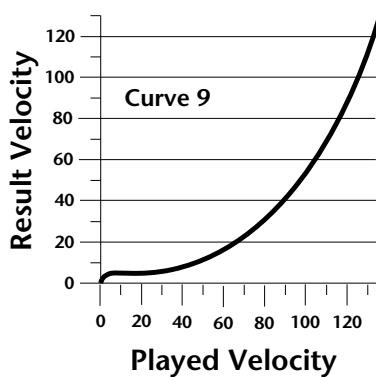
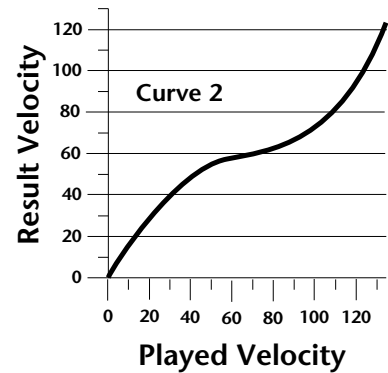
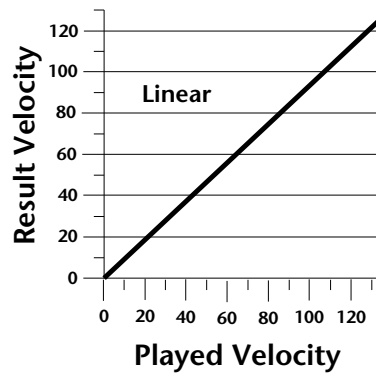

For a complete list of all available velocity curves, see “Velocity Curves” on page 211 of the Appendix.

## Mix Output

The Mix Output parameter allows you to override the routing assignments made in each preset and instead assign the outputs according to MIDI channel. For each of the 32 MIDI channels, you can select Send 1-4, or Preset. When Preset is selected, the output assignment defined in the Preset Edit menu is used.

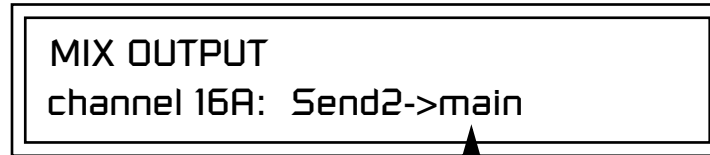

*Indicates that the dry signal is routed to the Main output jacks.*

The **Output Routing** field (pointed to by the arrow) reflects the true routing of Send 2 or Send 3 to either:

1) the effects processor input or... 2) the rear panel submix jacks.

Since the Sub 1 output is NOT being used, the signal is routed through the effects processors, then on to the main outputs. If a plug were inserted into one of the Sub 1 jacks the destination field would read "Sub1" and the dry signal would be routed directly to the Sub 1 outputs on the back panel.



### Send Routings

*Send 1 - Main Outputs*

*Send 2 - Subout 1 or Main Outs*

*Send 3 - Subout 2 or Main Outs*

*Send 4 - Main Outputs*

The Sends function as effect processor inputs (effect sends). Send 2 and Send 3 are also used to route sounds to the Sub 1 and 2 outputs on the back panel. When a plug is inserted into the associated Submix jack on the back panel, **the Dry portion of the Send is disconnected** from the effects processor and the signal is routed directly to the output jack. The actual output routing is shown in parentheses in the display. If you don't want the wet portion of the signal in the main mix, turn down the Send Level. *The entire Send is disconnected from the Effects Processors even if only one plug is inserted into the Submix jack.*

The four Effect Sends allow you to get the most out of the two effect processors. For example, with Effect B set to an echo algorithm, you could route one MIDI channel to Send 3 and set the effect amount to 80%. Another MIDI channel could be routed to Send 4 with an effect amount of only 5%. This is almost like having two different effects!

The Mix Output function is also useful when sequencing since it lets you route specific MIDI channels (and thus sequencer tracks) to specific Sub outputs (on the back panel) where there they can be processed with EQ or other outboard effects.

## OUTPUT SECTION & EFFECTS PROCESSORS

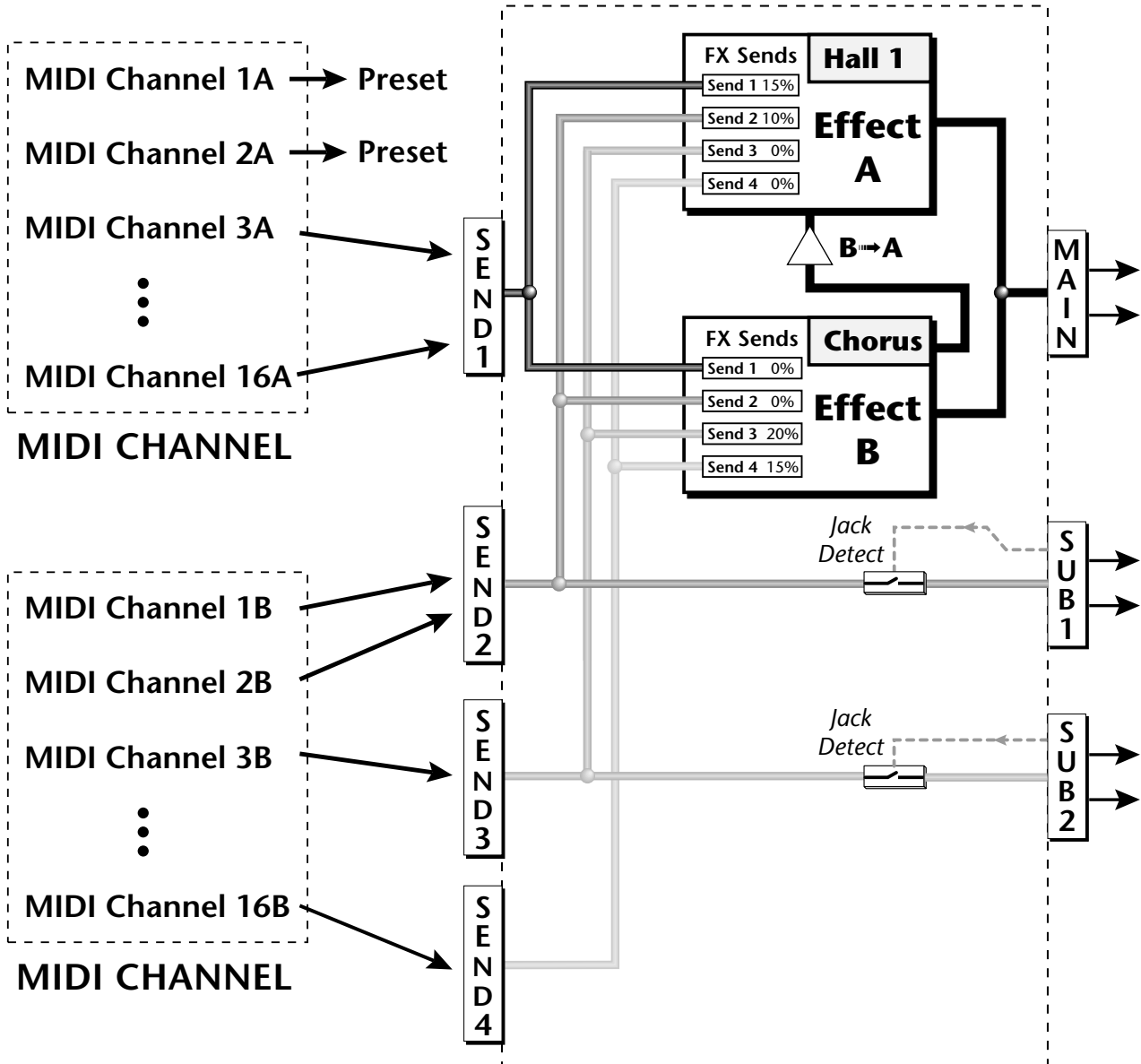

Sends 2 and 3 can be routed to the effects processors or to rear panel submix jacks. When a plug is inserted into a Submix jack, the dry portion of the Send is disconnected from the effects processor and is routed **directly** to the Submix output jacks.

## Mix Screens

The first two button switches the display to the Mix screens (volume & pan). The mix screens allow you view and adjust the volume and pan settings for all 32 channels. This is particularly useful when playing back a MIDI sequence. The volume and pan settings for all 32 channels are saved with the Multisetup. *See page 192.*

Mix Screen

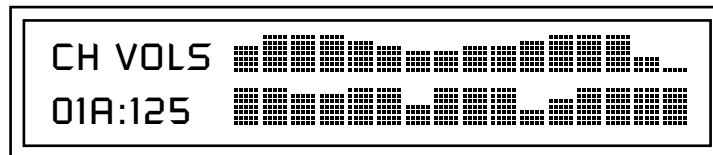

Pan Screen

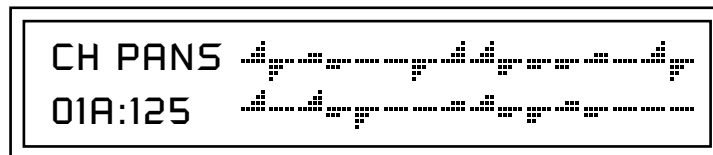

## Master Effects

The digital effect processors can be programmed as part of the preset (using the Edit menu) so that effects will change along with the preset. However, there are only two effect processors, and so you cannot have a different effect on each preset when in Multi mode.

The Master Effects settings assign the effect processors “globally” for all presets to provide a way to use the effects in Multi mode. Detailed information is presented in the Effects chapter (see Effects on page 173).

### Effects Mode

The FX Mode page enables or bypasses the effects. When the FX Mode is set to “bypass,” the effects are turned off on a global scale. This includes Effects programmed in the preset.

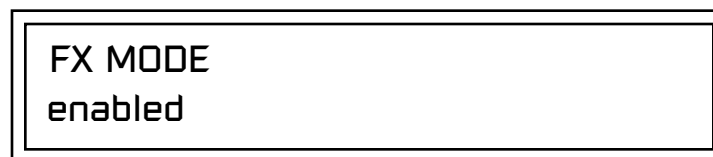

## Effects Multi Mode Control

The routing scheme for the two stereo effects processors provides a lot of versatility. When in multi mode, you can “use master settings” which applies the Master menu effects settings to all 32 MIDI channels.

**FX MULTIMODE CONTROL**  
use master settings

If you want more control, you can use the “channel” setting which applies the effects settings of the preset on a specified channel to all the other channels. Changing the preset on the specified channel changes the effect.

**FX MULTIMODE CONTROL**  
preset on channel 1A

If you are in Omni or Poly modes this parameter is disabled and the message in parentheses explains that Vintage Pro is currently in Omni mode.

**FX MULTIMODE CONTROL**  
(using Omni mode)

## Master FXA Algorithm

This function selects the type of effect used for the "A" effect. The following effect types are available.

**MASTER FXA ALGORITHM**  
Room 1

### A Effect Types

- |                     |                       |
|---------------------|-----------------------|
| 1. Room 1           | 23. BBall Court       |
| 2. Room 2           | 24. Gymnasium         |
| 3. Room 3           | 25. Cavern            |
| 4. Hall 1           | 26. Concert 9         |
| 5. Hall 2           | 27. Concert 10 Pan    |
| 6. Plate            | 28. Reverse Gate      |
| 7. Delay            | 29. Gate 2            |
| 8. Panning Delay    | 30. Gate Pan          |
| 9. Multitap 1       | 31. Concert 11        |
| 10. Multitap Pan    | 32. Medium Concert    |
| 11. 3 Tap           | 33. Large Concert     |
| 12. 3 Tap Pan       | 34. Large Concert Pan |
| 13. Soft Room       | 35. Canyon            |
| 14. Warm Room       | 36. DelayVerb 1       |
| 15. Perfect Room    | 37. DelayVerb 2       |
| 16. Tiled Room      | 38. DelayVerb 3       |
| 17. Hard Plate      | 39. DelayVerb 4 Pan   |
| 18. Warm Hall       | 40. DelayVerb 5 Pan   |
| 19. Spacious Hall   | 41. DelayVerb 6       |
| 20. Bright Hall     | 42. DelayVerb 7       |
| 21. Bright Hall Pan | 43. DelayVerb 8       |
| 22. Bright Plate    | 44. DelayVerb 9       |

### FXA Parameters: Decay/HF Damping FxB -> FxA

This page lets you define the parameters of the selected Effects algorithm. Use this page to setup the effect decay, high frequency damping amount and to route "B" effects through the "A" effects. See "Effect Parameters" on page 175 for more details.

**FXA    DECAY    HFDAMP    FxB>FxA**  
**040           096           001**



*FXA Send Amounts*

These parameters set the effects amounts for each of the four stereo effects busses. See “Master Effects” on page 178 for detailed information.

|                         |               |
|-------------------------|---------------|
| <b>FXA SEND AMOUNTS</b> | <b>1:100%</b> |
| <b>2: 50%</b>           | <b>3: 10%</b> |
|                         | <b>4: 0%</b>  |

*Master FXB Algorithm*

This parameter selects the type of effect used for the “B” effect. The following effect types are available.

|                             |
|-----------------------------|
| <b>MASTER FXB ALGORITHM</b> |
| <b>Chorus 1</b>             |

**B Effect Types**

|                |                        |
|----------------|------------------------|
| 1. Chorus 1    | 17. Ensemble           |
| 2. Chorus 2    | 18. Delay              |
| 3. Chorus 3    | 19. Delay Stereo       |
| 4. Chorus 4    | 20. Delay Stereo 2     |
| 5. Chorus 5    | 21. Panning Delay      |
| 6. Doubling    | 22. Delay Chorus       |
| 7. Slapback    | 23. Pan Delay Chorus 1 |
| 8. Flange 1    | 24. Pan Delay Chorus 2 |
| 9. Flange 2    | 25. Dual Tap 1/3       |
| 10. Flange 3   | 26. Dual Tap 1/4       |
| 11. Flange 4   | 27. Vibrato            |
| 12. Flange 5   | 28. Distortion 1       |
| 13. Flange 6   | 29. Distortion 2       |
| 14. Flange 7   | 30. Distorted Flange   |
| 15. Big Chorus | 31. Distorted Chorus   |
| 16. Symphonic  | 32. Distorted Double   |

*FXB Parameters:  
Feedback/LFO Rate  
Delay Time*

The FXB parameters setup the characteristics of the effect. Use this page to define the feedback amount, the LFO rate and delay amount for the selected type "B" effect. See "Effect Parameters" on page 175 for details.

|     |        |         |       |
|-----|--------|---------|-------|
| FXB | FEEDBK | LFORATE | DELAY |
|     | 000    | 003     | 0     |

*FXB Send Amounts*

These parameters set the effects amounts for each of the four stereo effects busses. See the Effects chapter for detailed information.

|                  |        |
|------------------|--------|
| FXB SEND AMOUNTS | 1:100% |
| 2: 50%           | 3: 10% |
|                  | 4: 0%  |

# MIDI Parameters

## MIDI Mode

MIDI parameters control how the Vintage Pro sends and receives MIDI data.

MIDI Mode selects one of the three MIDI modes: Omni, Poly or Multi mode.

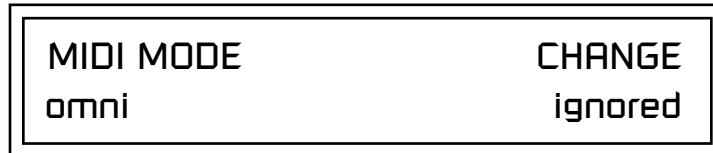

The **MIDI Mode Change** parameter specifies whether mode changes made through an external MIDI controller are accepted or ignored.

The MIDI modes are as follows:

### Omni

Responds to note information on all MIDI channels and plays the preset currently displayed in the main screen.

### Poly

Responds only to note information received on the currently selected MIDI channel (on the preset selection screen) and plays that channel's associated preset.

### Multi

Responds to data on any combination of MIDI channels and plays the specific preset associated with each of the MIDI channels. You must select multi mode for multitimbral operation.

## MIDI SysEx ID



**WARNING:** When transferring SysEx data from one Vintage Pro to another, the ID numbers of both units must be the same.

This page defines the MIDI system exclusive (SysEx) device ID number. The SysEx ID lets an external programming unit to distinguish between multiple Vintage Pro units connected to the same preset editor. In this case each unit must have a unique SysEx ID number.

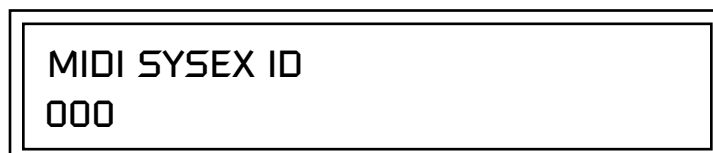

## MIDI Enable

MIDI Enable lets you turn each MIDI channel on and off independently when in Multi mode. This feature is helpful when you have other devices connected to the same MIDI line and do not want the Vintage Pro unit to respond to the MIDI channels reserved for the other devices.

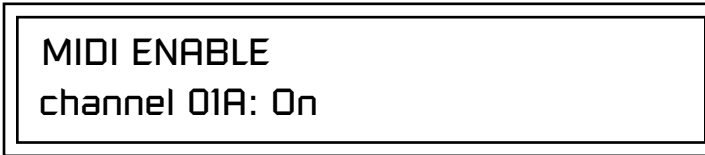

Because the MIDI Enable function only makes sense if you are in Multi mode, Vintage Pro disables this feature when in Omni or Poly mode.

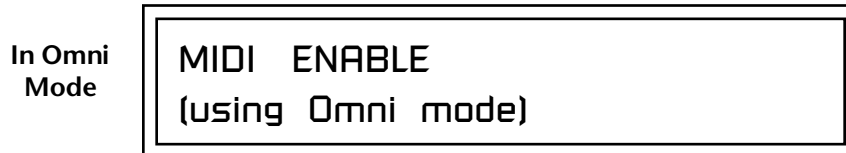
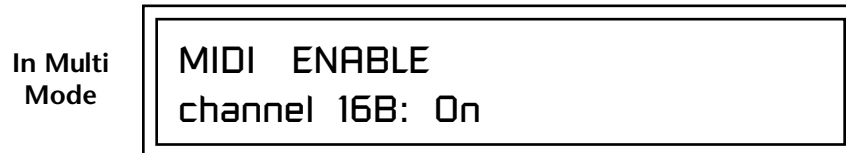

## MIDI Program Change -> Preset

You can also remap incoming MIDI program changes to a different numbered preset. This is a handy feature when your master keyboard cannot send a bank change or you want to reorder preset numbers. Any preset can be mapped to any incoming MIDI program change number.

For example, you could set up the Program -> Preset map to call up preset #12 whenever Vintage Pro receives MIDI program change #26.

The four fields shown below are editable.

 The Program->Preset Change only works for program changes received in Bank 0.

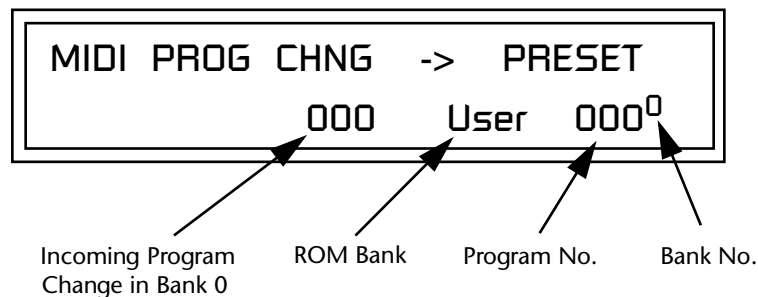

 Programs and presets are the same thing. "Preset" is the E-MU term for MIDI Program.

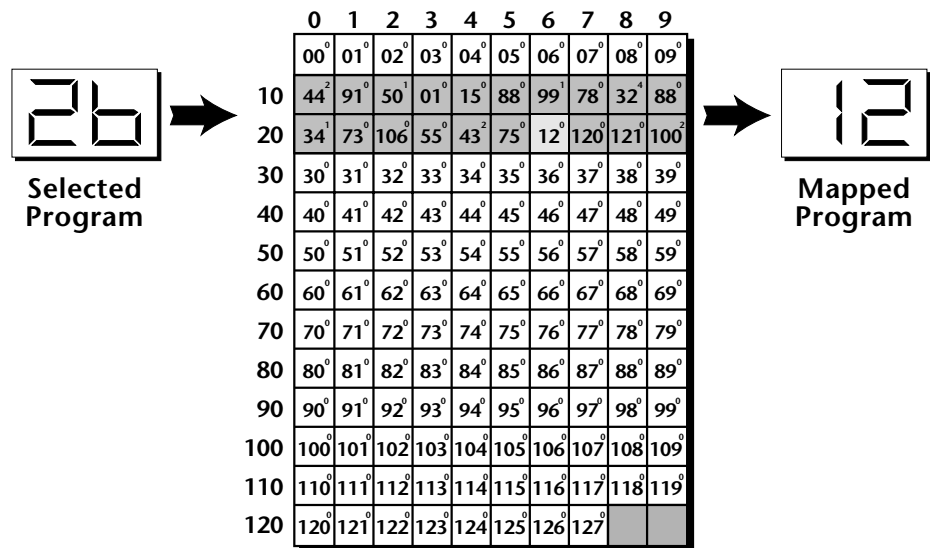

In this chart, program changes 10-29 have been remapped to new preset numbers. All other presets are selected normally.

### Receive Program Change

Use this function to instruct the Vintage Pro to utilize or ignore incoming MIDI preset changes or Bank Select commands for each channel. Use the cursor buttons to select the channel number field, then use the Data Entry Control to select a channel number. Use the cursor button again to select the On/Off field and the Data Entry Control to change the value.

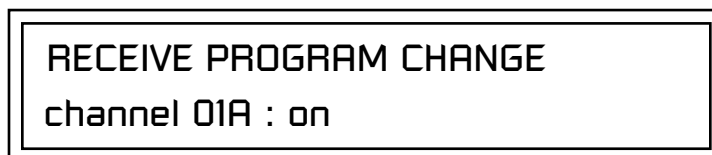

### Real-time Controller Assignment

Use these three pages to assign twelve real-time control sources. Each MIDI Controller is assigned a letter (A - L). The front panel Controller Knobs and twelve MIDI controller numbers share the A-L controller routings. **These screens let you select which MIDI real-time controllers numbers will be received (from 1 to 31 and from 64 to 119) and which controller numbers will be transmitted over MIDI if the front panel controls are turned.** The PatchCord routing and amount in the Edit menu determine what effect the controller has on each preset. Real-time controllers are shown in the PatchCord menu as MIDI A through MIDI L.

The Real-time Controller assignment also specifies which controller numbers are transmitted when the "Knobs MIDI Out" is enabled (see "Knobs/Riff MIDI Out" on page 78).

 Vintage Pro factory presets have certain synth parameters assigned to each controller letter and so these are "Global" controller assignments.

For example, assigning a MIDI controller number to "A" in this screen would let you control filter Fc for all the factory presets. See "Front Panel Knob Functions" on page 199.

For more information about realtime controllers see "MIDI Channels & Real-time Controls" on page 108.

|                       |       |       |       |
|-----------------------|-------|-------|-------|
| REALTIME CONTROLLER # |       |       |       |
| A: 21                 | B: 22 | C: 23 | D: 24 |

|                       |       |       |       |
|-----------------------|-------|-------|-------|
| REALTIME CONTROLLER # |       |       |       |
| E: 25                 | F: 26 | G: 27 | H: 28 |

|                       |       |       |       |
|-----------------------|-------|-------|-------|
| REALTIME CONTROLLER # |       |       |       |
| I: 80                 | J: 81 | K: 91 | L: 93 |

**Note:** Controllers 7 and 10 are already assigned to Volume and Pan for each MIDI channel. Controllers 91 & 93 are the standard controller numbers for reverb and chorus send amounts.

Following are a few of the standardized MIDI Controller numbers as defined by the MIDI manufacturers association. The controllers shown in **Bold** are automatically routed to the destination (volume & pan) or have their own PatchCord source. Others, such as Portamento Time, can be routed using a PatchCord to have the desired effect.

- |                             |                   |
|-----------------------------|-------------------|
| <b>1 - Modulation Wheel</b> | <b>7 - Volume</b> |
| 2 - Breath Controller       | 8 - Balance       |
| 3 - Old DX7 Aftertouch      | 9 - Undefined     |
| <b>4 - Foot Pedal</b>       | <b>10 - Pan</b>   |
| 5 - Portamento Time         | 11 - Expression   |
| 6 - Data Entry              |                   |

## MIDI Footswitch Assign

Like the MIDI Controllers, you can assign three MIDI footswitches to MIDI footswitch numbers. Footswitches numbers are from 64-79. Destinations for the footswitch controllers are programmed in the PatchCord section of the Edit menu.

|                         |       |       |
|-------------------------|-------|-------|
| FOOTSWITCH CONTROLLER # |       |       |
| 1: 64                   | 2: 65 | 3: 66 |

The following list shows a few of the standardized MIDI Switch numbers.

|                              |                            |
|------------------------------|----------------------------|
| 64 - Sustain Switch (on/off) | 67 - Soft Pedal (on/off)   |
| 65 - Portamento (on/off)     | 69 - Hold Pedal 2 (on/off) |
| 66 - Sostenuto (on/off)      |                            |

## Tempo Controller

This function allows a MIDI controller to change the Master Tempo. The Global Tempo is used for the clock divisor PatchCords, tempo-based envelopes and synced LFOs. You can assign any controller number from 0-31, mono key pressure, or the pitch wheel to change the Global Tempo. A different controller can be used to change the tempo up or down. The Pitch Wheel can be assigned to both the up and down parameters to vary the tempo up and down from a single controller. If any other controller is assigned to both the up and down parameters, Vintage Pro redefines the center of the controller's range as zero.

MIDI Controller values are added to the Base Tempo with an offset range of  $\pm 64$ . When the controller is set to "off" the tempo returns to its original setting. This control has no effect when using an external clock.

| TEMPO CONTROLLER#  | CHAN |
|--------------------|------|
| Up: 03    Down: 09 | 16A  |

## Knob Preset Quick-Edit

"Quick-Edit" changes the initial controller setting in the preset whenever you move a Control Knob. This parameter selects whether or not the front panel Controller Knobs are used to Quick-Edit the currently selected preset. See "Controller Knobs" on page 23 in the Operations chapter for more details.



Quick Edit does not work while in the Edit menu with "Knobs Deep Edit" enabled.

|  |
|--|
| <p><b>KNOBS PRESET QUICK-EDIT</b><br/>disabled</p> |
|--|

*Knobs  
Deep Edit*

This parameter specifies whether or not the front panel controller knobs can be used to edit parameter values in the Master or Edit menus. This is called “Deep-Editing.” With Knob Deep Edit disabled, the front panel controller knobs retain their function as real-time controllers even when in the Master or Edit modes.

**KNOBS DEEP EDIT**  
disabled

*Knobs/Riff MIDI Out*

This function allows you to select whether or not MIDI controller data is transmitted when you turn the front panel Controller knobs. The knobs transmit on the controller numbers defined by the Real-time Controller Assign parameter (see page 75). This function also enables or disables transmission of Riff note data over MIDI when the Audition button is pressed.

If Deep Edit is enabled, “Knobs MIDI Out” does not work while in any of the editing menus (Master, Edit, Save/Copy).

**KNOBS/RIFF MIDI OUT**  
don't transmit

*Preset Edit All Layers  
Enable*

This function allows you to turn the Edit All Layers feature on or off. “Edit All Layers” is an Edit menu feature which allows you to select all layers (A) in order to edit all four layers simultaneously. Because this feature can be confusing to the beginning programmer, it can be disabled here in the Master menu. Check this feature out when you’re ready. It’s great!

**PRESET EDIT ALL LAYERS**  
enabled



## Front Panel Knob Calibration

This function calibrates the minimum and maximum values for the five front panel knobs. The controls should be calibrated periodically in order to compensate for normal wear and tear on the controls themselves or if the controls behave strangely. Before calibration, it's usually a good idea to let the unit warm up for about half an hour to ensure you have the maximum range on all the front panel controls.

### ► To Calibrate the Front Panel Control Knobs

1. Press the Master menu button and advance to the Calibrate Knobs page.

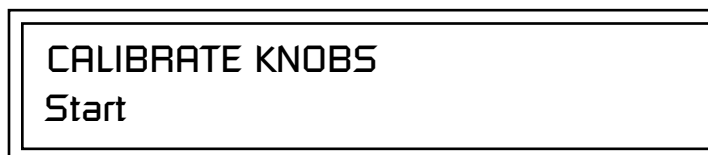

CALIBRATE KNOBS  
Start

2. Press the Enter button to begin the calibration process. The following screen appears.

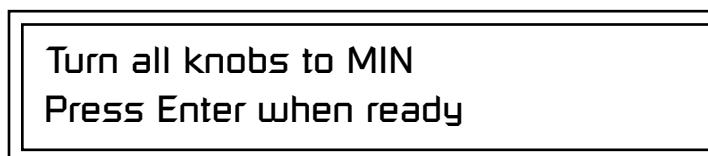

Turn all knobs to MIN  
Press Enter when ready

3. Turn all knobs to their minimum value (which is pegged in the counter-clockwise direction), then press the Enter button. The screen briefly flashes, "Reading Values...", then displays:

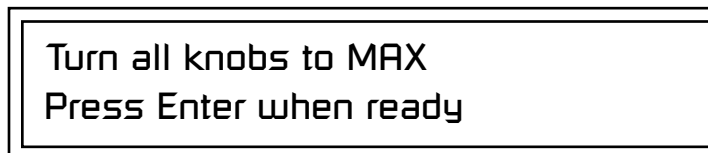

Turn all knobs to MAX  
Press Enter when ready

4. Turn all knobs to their maximum value (pegged in the clockwise position), then press the Enter button. The display shows, "Reading Values... Done." Calibration is complete.

## MIDI SysEx Packet Delay

Sometimes errors occur if the computer or sequencer to which you are sending MIDI SysEx data is faster or slower than the Vintage Pro. The MIDI SysEx Packet Delay command lets you specify the amount of delay between MIDI SysEx packets so the input buffer of your computer does not overflow, causing an error. The value range is from 0 through 8000 milliseconds. A delay value of zero allows full speed MIDI transfer. If you are experiencing data transmission errors, try increasing the delay value until the problem disappears.

MIDI SYSEX PACKET DELAY  
300 milliseconds

## Send MIDI System Exclusive Data

This command transmits MIDI System Exclusive (SysEx) data to the MIDI Out port of Vintage Pro. The MIDI data can be sent to a computer, sequencer or to another Vintage Pro. When transferring data between two Vintage Pros be sure both units have the same SysEx ID number! See "MIDI SysEx ID" on page 73 to learn how to change the SysEx ID.

Using the cursor key and the Data Entry Control, select the type of MIDI data you want to transmit. Following are descriptions of the types of MIDI data that can be transmitted.

### Current Multisetup

Transmits all parameters in the Master menu except Tuning Tables, Program/Preset Map and Viewing Angle.

### Program /Preset Map

Transmits the MIDI Program -> Preset Map.

### All User Tuning Tables

Transmits all 12 user User Tuning Tables.

### Multimode Map

Transmits the following parameters:

- Multimode Basic Channel
- Multimode Effects Control Channel
- Multimode Tempo Control Channel

*and for each MIDI Channel...*

- Preset, Volume, & Pan
- Mix Output
- Multimode Channel Enable
- Multimode Bank Map
- Multimode Receive Program Change

 The Preset, Volume, and Pan information for all 32 channels is included when the Multi mode Map settings are transmitted or received.



**WARNING:** When transferring SysEx data from one Vintage Pro to another, the ID numbers of both units must match.

### Bank 0 User Presets

Transmits all the user defined presets in Bank 0.

### Bank 1 User Presets

Transmits all the user defined presets in Bank 1.

### Bank 2 User Presets

Transmits all the user defined presets in Bank 2.

### Bank 3 User Presets

Transmits all the user defined presets in Bank 3.

### Any Individual Preset

Transmits only the selected preset.

The Enter LED will be flashing. Press the Enter button to confirm the operation. To receive MIDI data, simply send the MIDI data into Vintage Pro from another Vintage Pro or from a computer/sequencer.



#### ► To Record MIDI SysEx Data into a Sequencer:

1. Setup the sequencer to receive system exclusive data.
2. Place the sequencer into record mode, then Send MIDI Data.

#### ► To Receive MIDI SysEx Data from a Sequencer:

Simply play back the sequence into Vintage Pro.

## User Key Tuning

User Key Tuning lets you create and modify 12 user definable tuning tables. The initial frequency of every key can be individually tuned, facilitating the creation of alternate or microtonal scales.

Using the cursor keys and the Data Entry Control, select the user table number, the key name, the coarse tuning and the fine tuning. The key name is variable from C-2 to G8. Coarse Tuning is variable from 0 to 127 semitones. The fine tuning is variable from 00 to 63 in increments of 1/64 of a semitone (approx. 1.56 cents). For each preset, the specific tuning table is selected in the Edit menu.



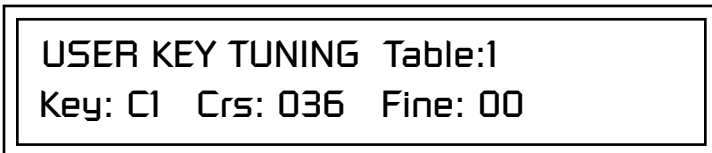

The user key tuning can be used to tune individual percussion instruments.

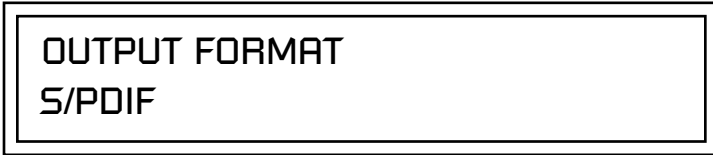

## Output Format

The Output Format parameter sets the digital audio output format. The available formats are S/PDIF, and AES pro. If you are using the digital output, choose either S/PDIF or AES pro to match the format of the receiving device.



 **DON'T CHEAP OUT!**  
Always use high quality cable for digital audio connections.

The Vintage Pro contains a S/PDIF digital output. The diagram below shows how an adapter cable for AES pro should be wired.

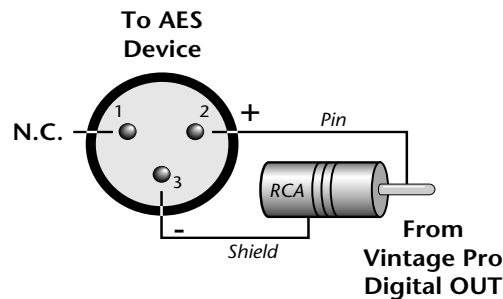

If you use an adapter cable to connect the S/PDIF digital audio output to AES gear, make sure to use high quality, low capacitance cable.

## Screen Viewing Angle

This function changes the viewing angle of the display so that you can read it easily from either above or below the unit. The angle is adjustable from +7 to -8. Positive values will make the display easier to read when viewed from above. Negative values make the display easier to read from below.

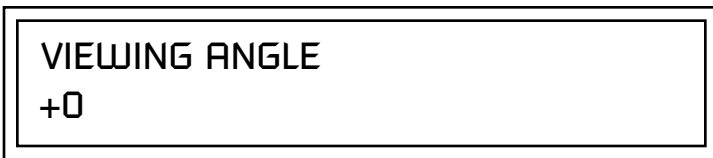

# *Programming Basics*

This chapter explains how Vintage Pro sounds are constructed and contains important background information on how to create your own custom presets.

Your initial involvement with Vintage Pro will most likely be using the existing presets and selecting MIDI channels. While the factory presets are very good, there are some things you will probably want to change eventually, perhaps the LFO speed, the filter frequency or the attack time. You may also want to make your own custom presets using complex modulation routings. There are 512 user locations (User Banks 0-3) available to store your own creations or edited factory presets. Best of all, it's easy to edit or create new presets using the Edit menu.

Each preset can consist of up to four instrument layers. Each of the four layers can be placed anywhere on the keyboard and can be crossfaded or switched according to key position, velocity, or by using a real-time control such as a wheel, slider, pedal, LFO or envelope generator. A preset can also be "linked" with up to 2 more presets creating additional layering or splits.

Vintage Pro has an extensive modulation implementation using two multi-wave LFO's (Low Frequency Oscillators), three multi-stage envelope generators and the ability to respond to multiple MIDI controllers. You can simultaneously route any combination of these control sources to multiple destinations.

## Modulation

To modulate means to dynamically change a parameter, whether it be the volume (amplitude modulation), the pitch (frequency modulation), and so on. Turning the volume control on your home stereo rapidly back and forth is an example of amplitude modulation. To modulate something we need a modulation source and a modulation destination. In this case, the source is your hand turning the knob, and the destination is the volume control. If we had a device that could turn the volume control automatically, we would call that device a modulation source.

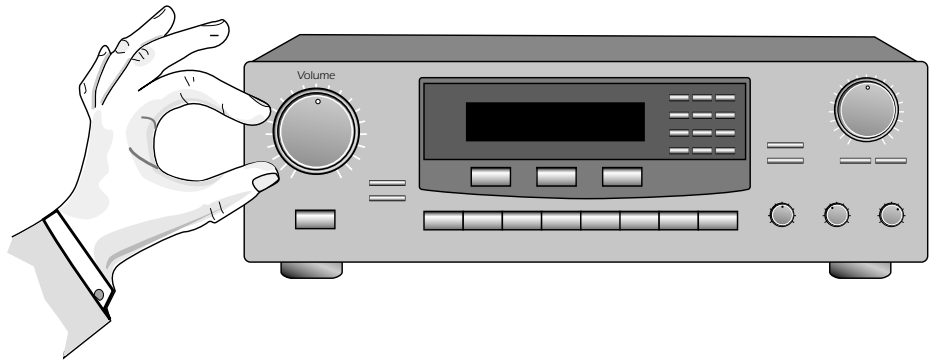

Turning the volume control back and forth on your home stereo is an example of Amplitude Modulation.

Vintage Pro is designed so that each of the variable parameters, such as the volume, has an initial setting which is changed by a modulation source. Therefore in the case of volume, we have an initial volume that we can change or modulate with a modulation source.

Two main kinds of modulation sources on Vintage Pro are *Envelope Generators* and *Low Frequency Oscillators*. In the example above, an envelope generator could be routed to automatically turn the volume control as programmed by the envelope. Or, a low frequency oscillator could be routed to turn the volume up and down in a repeating fashion.

Positive modulation adds to the initial amount. Negative modulation subtracts from the initial amount.

### Summing Nodes

All the modulation inputs on Vintage Pro are summing nodes. This means that you can connect as many modulation sources as you want to an input (such as *Pitch* or *AmpVol*). Modulation sources are simply added algebraically— connecting two knobs, one set to -100 and the other set to +100 yields a net value of zero.

## Modulation Sources



**Tip:** Try routing *Key Glide* to *Filter Frequency* if you want the filter to smoothly follow pitch in solo mode. Routing *Key Glide* to *Pan* creates another interesting effect.

Modulation sources include *Envelope Generators*, *Performance Controllers* and *Low Frequency Oscillators*. In the previous example, an envelope generator was routed to automatically turn the volume control as programmed by the envelope, or, a low frequency oscillator could be routed to turn the volume control up and down in a repeating fashion. The following is a list of the modulation sources used in Vintage Pro.

### **Keyboard Key**

Which key is pressed.

### **Key Velocity**

How fast the key is pressed.

### **Release Velocity**

How fast the key is released.

### **Gate**

High if the key is pressed, low when the key is released.

### **Key Glide**

A smoothly changing control source based on the *Glide Rate* and the interval between the last two notes played.

### **Pitch and Mod Wheels**

Synthesizer pitch bend and modulation wheels.

### **Keyboard Pressure (mono aftertouch)**

Key Pressure applied after the key is initially pressed.

### **Pedal**

A continuously variable pedal controller.

### **Miscellaneous Controllers A -L**

Any type of MIDI continuous controller data.

### **Low Frequency Oscillators (2 per layer)**

Generate repeating waves.

### **Envelope Generators (3 per layer)**

Generate a programmable “contour” which changes over time when a key is pressed.

### **Noise & Random Generators**

Generate spectrums of noise and random signals.

### **Footswitches**

Change a parameter when the switch is pressed.

### **Clock Divisor**

The master tempo clock can be divided and used as a modulation source.

## Random Sources

Random modulation sources can be used when you want the timbre of the sound to be “animated” in a random or non-consistent manner.

- **Key Random 1 & 2** generate different random values for each layer which do not change during the note.
- The **White & Pink Noise** Generators produce varying random values. Both white and pink noise sources are low frequency noise designed for control purposes. Either noise source can be filtered even more by passing it through a lag processor.
- The **Crossfade Random** function generates the same random value for all layers in a preset. This source is designed to be used for cross-fading and cross-switching layers, although you may find other uses.

## Modulation PatchCords

 The controller Knobs assignments printed on the front panel are the system defaults. You can change any of these assignments using the Real-time Controller Assignment page in the Master menu (see page 75 for details).

When setting up modulation with the Vintage Pro, you define a modulation source and a modulation destination. Then, you connect the source to the destination using “PatchCords.” Vintage Pro’s PatchCords are connected in the software. Vintage Pro has 24 general purpose PatchCords for each layer.

You can connect the modulation sources in almost any possible way to the modulation destinations. You can even modulate other modulators. Each PatchCord also has an amount parameter which determines “how much” modulation is applied to the destination. The modulation amount can be positive or negative. Negative values invert the modulation source.

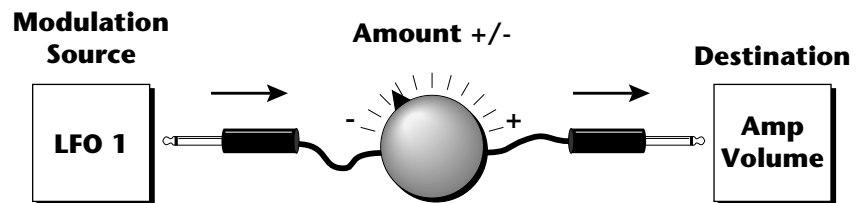



## Envelope Generators



If two adjacent segments have the same level in a “time-based” envelope, the segment will be skipped. Adjacent segments must have different levels for the rate control to work.

An envelope can be described as a “contour” which is used to shape the sound over time in a pre-programmed manner. There are three envelope generators per layer and all of them are the rate/level type.

This is how the rate/level (*time based*) envelopes work: When a key is pressed, envelope starts from zero and moves toward the Attack 1 Level at the Attack 1 Rate. As soon as it reaches this first level, it immediately begins the next phase and moves toward the Attack 2 level at the Attack 2 rate. As long as the key is held down, the envelope continues on through the Decay 1 and Decay 2 stages. If the key is still held when the envelope reaches the end of Decay 2, it simply waits there for you to release the key. When you release the key, the envelope continues into the Release 1 and Release 2 stages, stopping at the end of the Release 2 stage. Vintage Pro’s envelope generators provide great flexibility for programming both complex and simple envelopes.

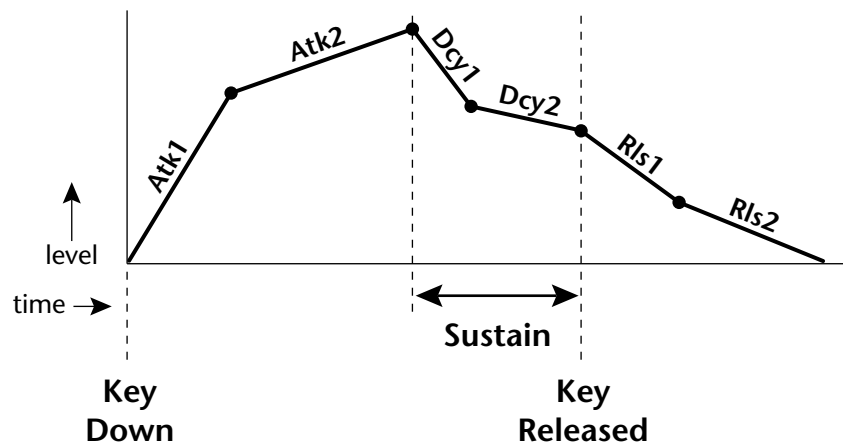

All three envelope generators have the six stages described above. The Volume Envelope generator controls the volume of the voice over time. The Filter Envelope generator is a general purpose envelope most often used to control the filter frequency. Unlike the Volume Envelope, however, the Filter Envelope can have a negative level value as well as a positive level. There is also an Auxiliary Envelope generator which is a general purpose envelope. The Auxiliary Envelope is identical to the Filter Envelope and can have negative as well as positive levels. You can adjust the time of each stage to create myriad envelope shapes, which in turn shape the sound over time.



By routing the Auxiliary or Filter Envelopes to control the pitch (PatchCords) you can easily hear the shape of the envelopes you are creating.

- Volume envelopes contour the way the volume of a sound changes over time determining how we perceive that sound. For example, a bell struck with a hammer is instantly at full volume, then slowly dies away. A bowed violin sound fades in more slowly and dies away slowly. Using Vintage Pro’s Volume Envelope, you can simulate the different types of natural instrument volume envelopes by programming them appropriately.

### Tempo-based Envelopes

Tempo-based envelopes are based on *Time* which is controlled by the Master Tempo (located in the Master menu). The Master Tempo rate scales the time of the Tempo-based envelope segments. The Master Tempo can also be set to use an external MIDI clock so that the envelope times can be synchronized to external sequencer or arpeggiator tempo changes.

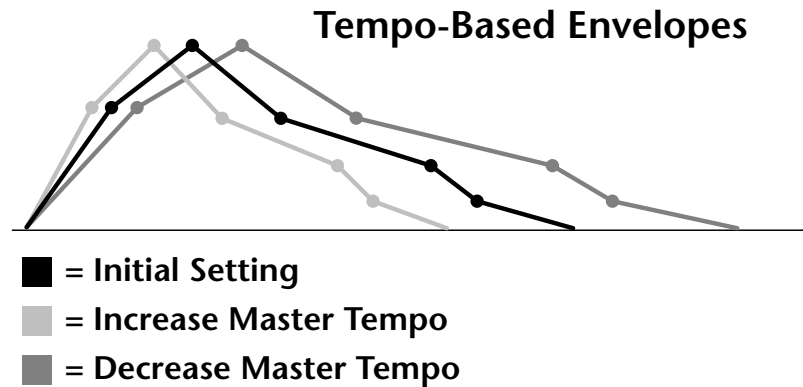

### Envelope Repeat

The Envelope Generators can also be made to repeat. When the envelope repeat function is On, the Attack (1&2) and Decay (1&2) stages will continue to repeat as long as the key is held. As soon as the key is released, the envelope continues through its normal Release stages (1 & 2).

 Only the Filter and Auxiliary Envelopes have the repeating feature.

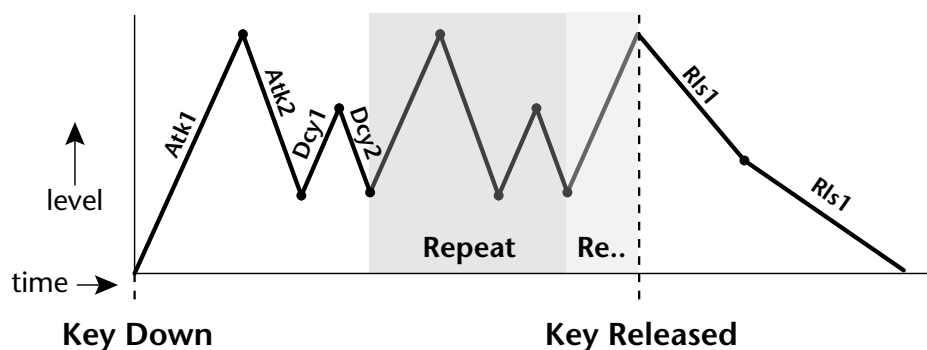

The diagram above show how the looping envelopes work. When the key is pressed the envelope goes through its regular Attack 1, Attack 2, Decay 1 and Decay 2 stages. In non-looping mode, the envelope would hold at the end of the Decay 2 stage until the key was released. In looping mode however, it jumps back to the Attack 1 stage and repeats the first four stages. It continues to loop through these four stages until the key is released where it immediately jumps to the Release 1 stage.

# Low Frequency Oscillators (LFOs)

## LFO Tricks & Tips:

- The Random LFO wave is truly random and is different for each voice and layer.
- The Pattern (Pat) waveforms will sound the same on different layers and voices.
- Sine + Noise is very useful for simulating trumpet and flute vibrato.

### ★ When routing Hemi-quaver to Pitch:

- +38 = major scale
- 38 = phrygian scale
- +76 = whole tone scale
- (+38) + (+76) = diminished (two cords)
- odd amount = S+H sound

**Note:** References to musical intervals in the pattern LFO shapes are with the LFO routed to pitch and a PatchCord amount of +38.

 Try combining the Pattern LFOs, or controlling the amount of one with another, or combining them with the clock divisors.

A Low Frequency Oscillator or LFO is simply a wave which repeats at a slow rate. The Vintage Pro has two multi-wave LFOs for each channel. The LFO waveforms are shown in the following illustration.

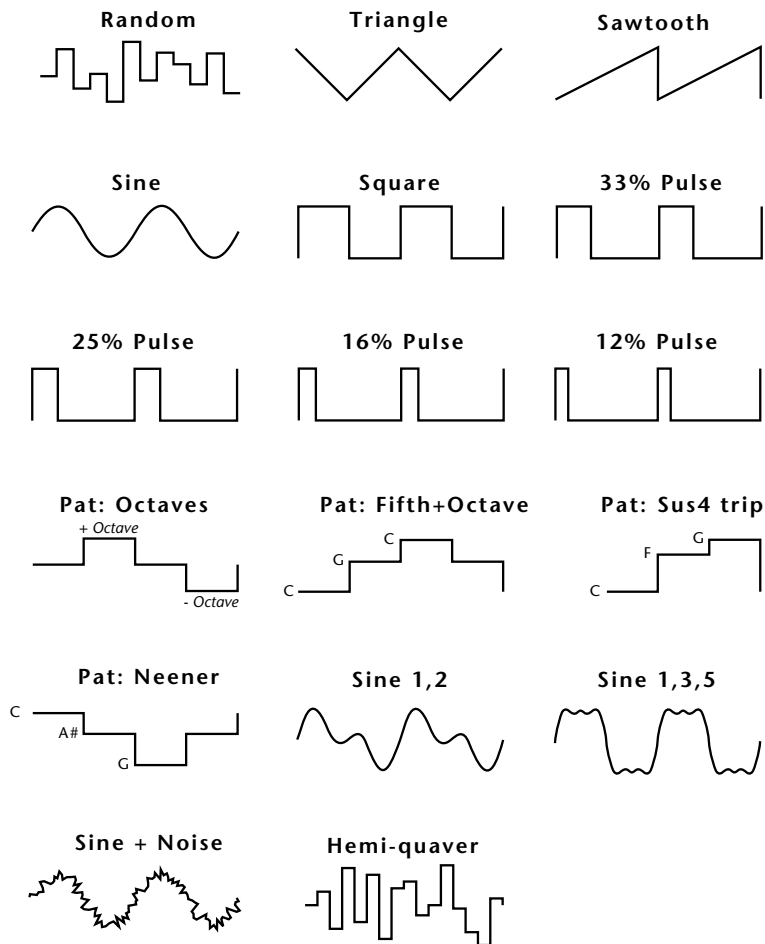

By examining the diagram of the LFO waveforms, you can see how an LFO affects a modulation destination. The shape of the waveform determines the result. Suppose we are modulating the pitch of an instrument. The sine wave looks smooth, and changes the pitch smoothly. The square wave changes abruptly and abruptly changes from one pitch to another. The sawtooth wave increases smoothly, then changes back abruptly. The sound's pitch follows the same course. Controlling the pitch of an instrument is an easy way to hear the effects of the LFO waves.

Like the Auxiliary Envelope, LFOs can be routed to control any real-time function such as Pitch, Filter, Panning, or Volume. A common use for the LFO is to control the pitch of the sound (LFO -> Pitch). This effect is called vibrato and is an important performance effect. Many presets use this routing with the modulation wheel controlling "how much" LFO modulation is applied. Another common effect, Tremolo, is created by controlling the volume of a sound with the LFO (LFO -> Volume).

You might use the LFOs to add a slight bit of animation to the sound by routing the LFO to control the filter. For this effect, set the LFO “amount” low for a subtle effect.

When a PatchCord amount is a negative value, the LFO shape is inverted. For example, inverting the sawtooth wave produces a wave that increases abruptly, then smoothly glides down.

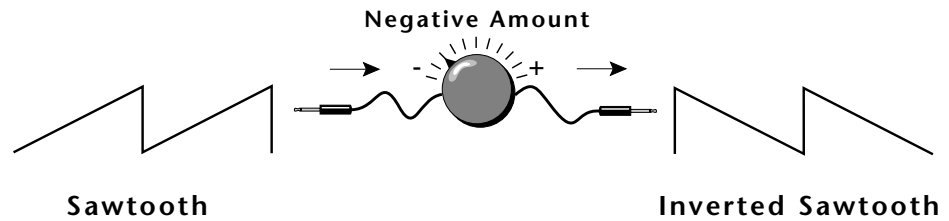

## Clock Modulation

 Envelopes are triggered on the positive going edge of the clock. LFOs are triggered on the negative going edge of the clock.

 The tempo of the master clock is set in the Master menu.

You can use the Master Clock as a modulation source, to trigger the Filter or Auxiliary Envelope generators, trigger Sample Start, synchronize the LFOs, or directly as a square wave modulation source. The Clock source is available in eight divisions (octal whole note, quad whole note, double whole note, whole note, half note, quarter note, eighth note, sixteenth note). You can use the different rates separately or in conjunction to create complex “synchro-sonic” rhythm patterns. You can also use a MIDI Clock as the Master Clock to synchronize to an external MIDI device such as a drum machine or sequencer. (See *Master Tempo* in the *Master* menu.)

Clocks are routed exactly like the other modulations sources using the PatchCords. The PatchCord Amount MUST be positive (+) for the clock to pass. By modulating the PatchCord Amount, you can route the divided clocks using real-time controllers or other modulation sources.

When an LFO is triggered by a clock, the LFO wave resets to zero every time the clock wave goes low. If the LFO rate is close to the clock rate, the LFO virtually synchronizes with the clock. If the two rates are far apart, the waveform of the LFO will be mildly or radically altered.

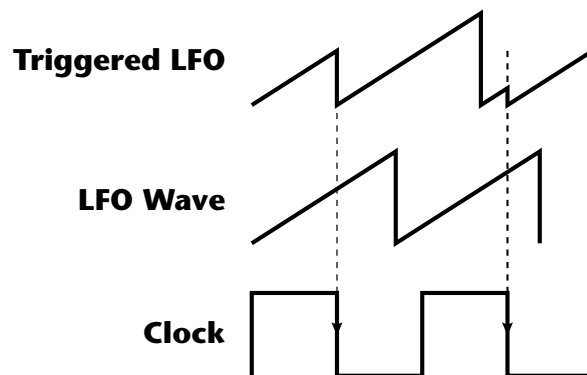

LFO Trigger causes the LFO to reset each time the clock waveform goes low.



LFO Synced to 1/4 Note Clock

LFOs can also be perfectly synchronized with the clock at any of 25 note divisions. This allows you to create very cool “synchro-sonic” effects that work perfectly at any tempo. Choosing one of the note divisors in the LFO rate screen selects the synced LFO function.

There are many possibilities for clock modulation and retrigger. For example, you can create a repeating six segment curve of any shape by triggering the Filter or Auxiliary Envelope generators with the clock. A few other possibilities are listed below.

- Turn different voice layers on and off using different clock divisors.
- Switch between Auxiliary and Filter Envelope retriggering using a slider or footswitch.
- Retrigger LFOs or Envelopes using noise or other LFOs to create random or semi random effects.
- Alter the LFO waveform by modulating the rate of a triggered LFO.
- Route multiple clocks with different divisors to the same destination (such as pitch) to create complex patterns. (*Hint: Adjust the PatchCord Amounts.*)

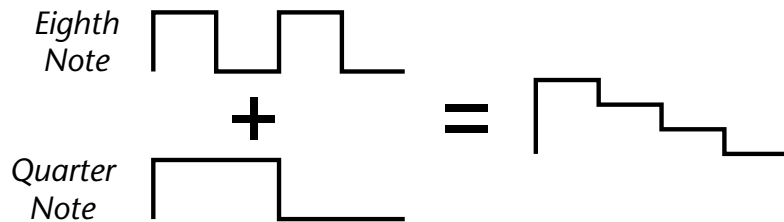

Adding these two clocks together in equal amounts produces a stairstep waveform.

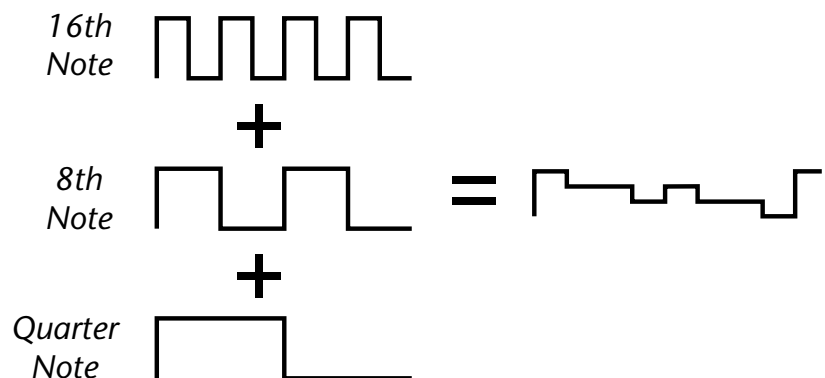

Adding multiple clocks with unequal amounts produces complex repeating patterns.

# Modulation Destinations

The PatchCords section of the Edit menu is where you connect sources to destinations. Each PatchCord has an amount associated with it which controls how much modulation is applied.

|    |           |              |
|----|-----------|--------------|
| L1 | PATCHCORD | #01          |
|    | ModWhl -> | RTXfade +036 |

The PatchCords screen above and the diagram below show how modulation sources are connected to destinations. The modulation sources can control any of the destinations in the layer.

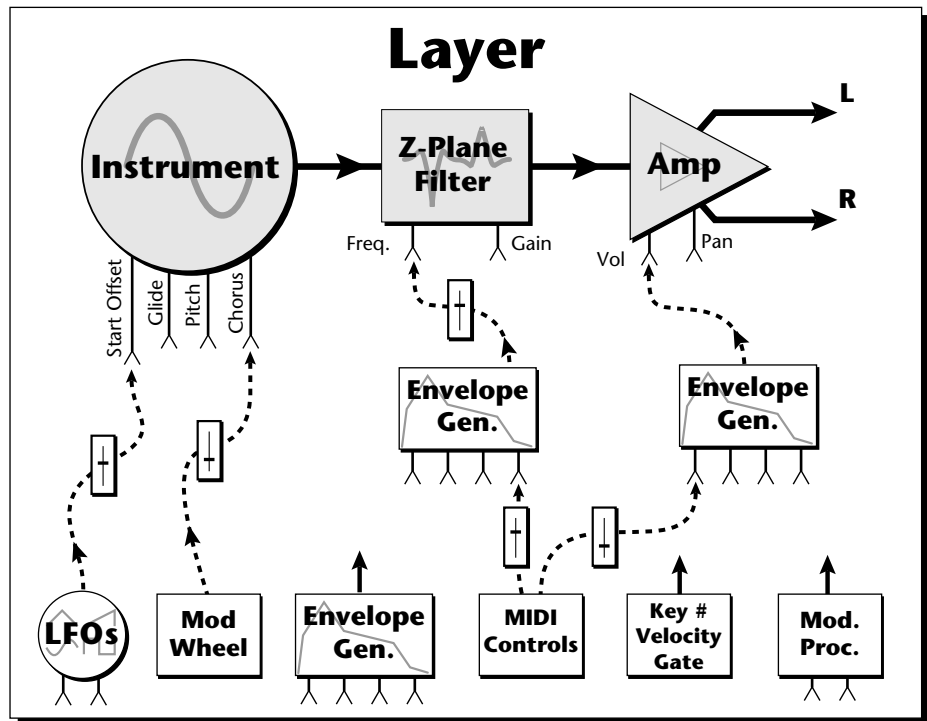

- Note-on modulation sources, such as key, velocity and gate output a single value at note-on time. Realtime modulation sources such as LFOs, envelope generators and modulation wheels can be varied continuously.

The possible modulation routings are completely flexible as shown in the diagram above. Multiple sources can control the same destination, or a single source can control multiple destinations.

## Modulation Processors

Modulation processors are devices which can modify modulation sources such as LFOs and envelope generators before they are applied to a destination. Modulation processors let you create patches and do tricks which would not be possible otherwise. Vintage Pro implements the following modulation processors:

### Switch

Outputs a digital “1” when the input is greater than “0”.

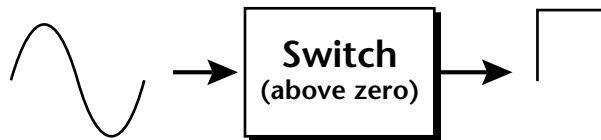

### Summing Amp

Lets you add several modulation signals together before applying them to a destination. This processor can save PatchCords when routing the output to multiple destinations.

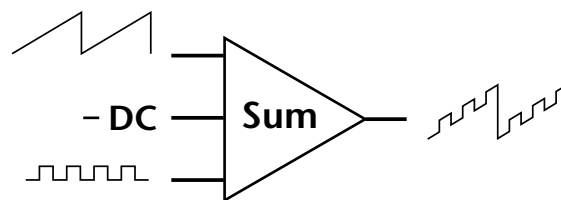

### Lag Processors

Slows down rapid changes in the input signal. The output “lags” behind the input at a pre-programmed rate. There are two lag processors, Lag 0 and Lag 1. Lag 1 has a longer lag time than Lag 0.

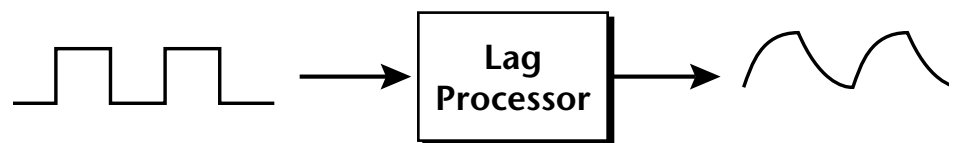

### Absolute Value

This function inverts negative input values and outputs only positive values. This device is also called a full wave rectifier.

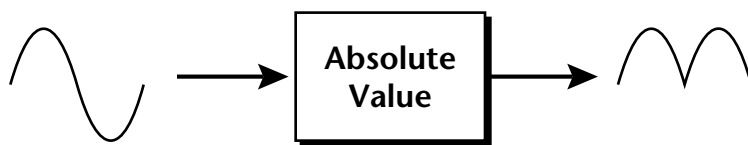

### Diode

The diode blocks negative input values, passing only positive values.

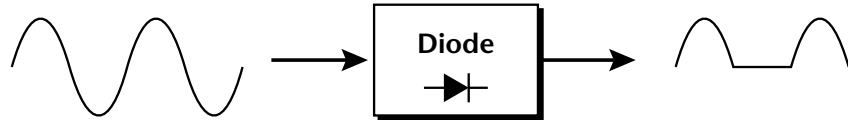

### Flip-Flop

The output of this processor alternates between a digital "1" and digital "0" each time the input goes positive from zero or a negative value. With an LFO input, the output will be a square wave of half the input frequency.



 The value of a digital "1" is equal to the PatchCord amount.

### Quantizer

With the input PatchCord set to 100%, the output value is limited to 16 discrete values. The value of the input PatchCord controls the number of steps. The value of the output PatchCord controls the size of the steps.

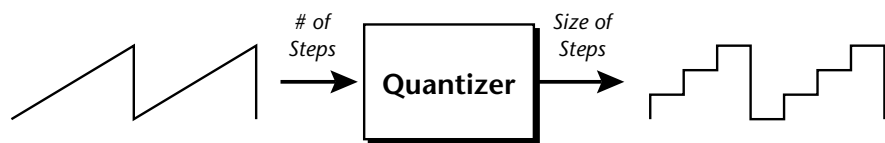

### 4x Gain

This processor amplifies the modulation source by a factor of 4.

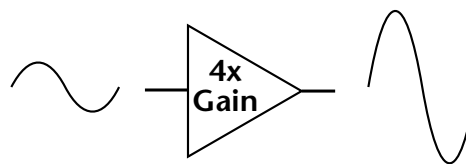

### Lag Inputs

The Lag processors can be used as 2 additional summing amps. Lag0sum and Lag1sum are modulation sources which equal the sum of PatchCords connected to the Lag in destination. The summing amp is located before the lag processor as shown in the following illustration.

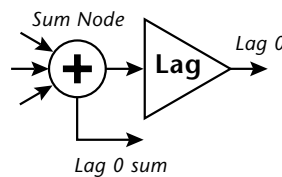



# Preset Modulation Processors



*Preset Modulation Processors start working as soon as the preset is selected. The Layer Modulation Processors take effect only when a key is pressed.*

There are also two “Preset Level” modulation processors located in the “Preset Patchcords” screen of the Edit menu. It is important to understand that although the preset processors *originate* at the *Preset Level PatchCords*, their output is used in the *Layer PatchCords*.

## Preset Lag

Like the Layer Lag processors (*described on page 93*) the Preset Lag slows down rapid changes in the input signal. The output “lags” behind the input at a pre-programmed rate. Unlike the layer level lag processors, the *preset lag* takes effect as soon as the preset is selected. In contrast, the layer level lag processors begin acting only after a keyboard key has been depressed. The Preset Lag also has a *Lag Amount* input which controls the lag time. Positive lag amounts increase the lag time. A MIDI controller (*such as a front panel knob*) is commonly used to control lag amount.

The preset lag could be used to “spin-up” and “spin-down” an LFO, which is controlling some other effect, perhaps left/right panning, pitch, or the filter. A MIDI footswitch could be used as the input to the lag which acts to slow down the instantaneous change of the switch. The slowly changing output value is then routed using a layer patchcord to crossfade between layers or change the speed of an LFO.

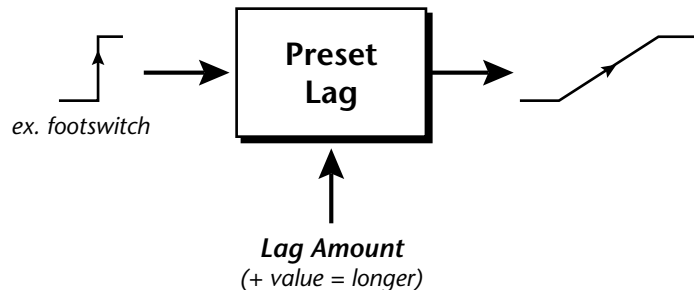

## Preset Ramp

This processor generates a positive or negative going slope whenever the **first** key is depressed on the MIDI channel.

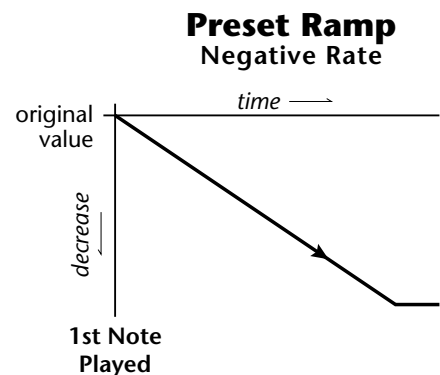
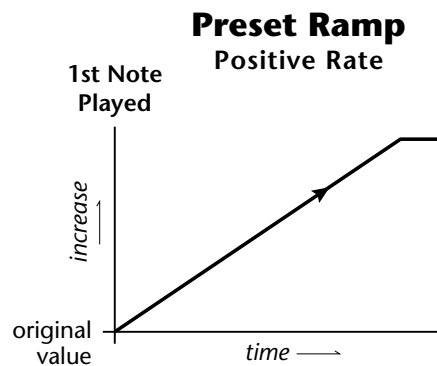

The preset ramp instantly resets when all notes have been released and the next *first key* on the MIDI channel is pressed. The Ramp Rate polarity (+ or -) determines if the ramp will be positive or negative going. The value of the ramp rate sets the increment. Large values produce fast ramps and small values produce slow ramps. Multiple inputs can be connected to the ramp rate (just like all the other destinations in Vintage Pro).

The patch below shows an application for the Preset Ramp which generates an adjustable decay envelope ONLY on the first note played to bring in the sound from another layer. Instead of routing the output to the Amp Volume you could just as easily route it to control Pitch, LFO Speed or any other destination you can think of. Study this patch if you want to learn a few new tricks using the patchcords.

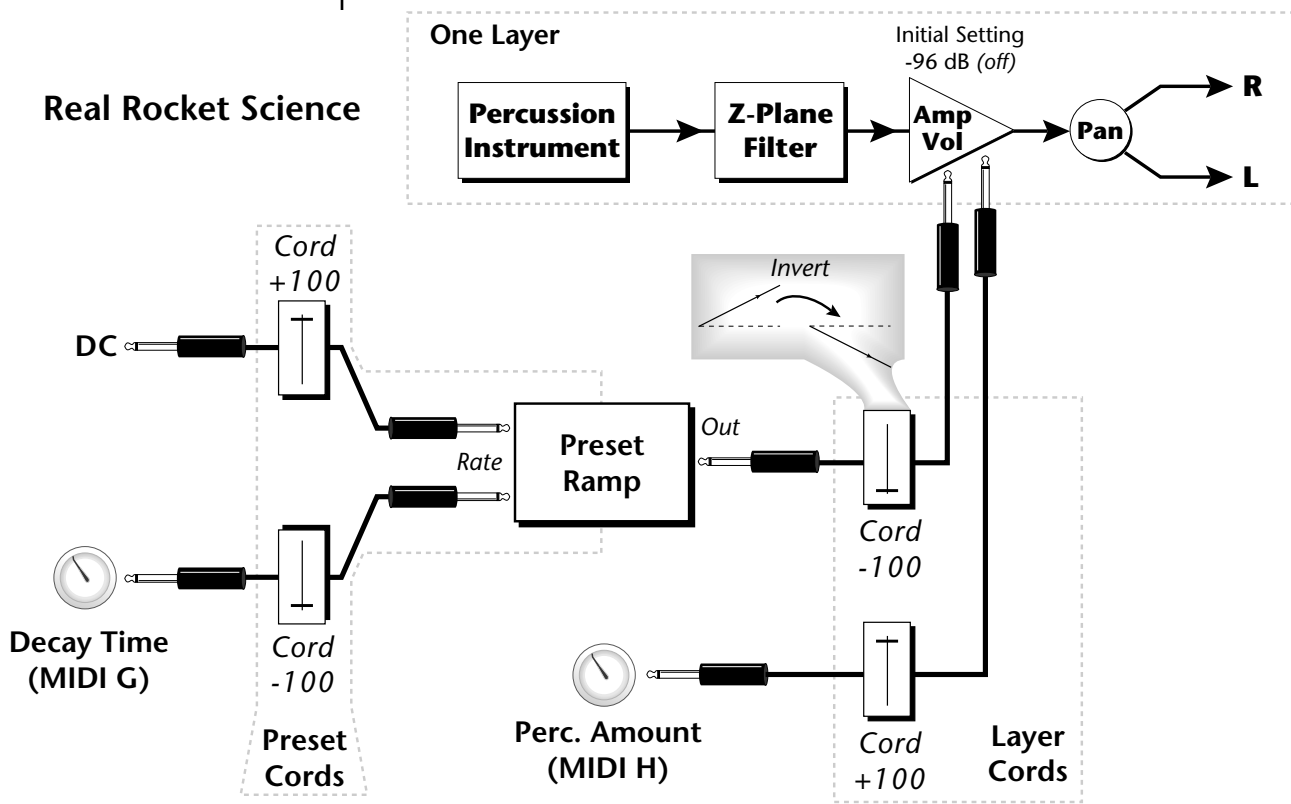

 The combination of the DC & Perc. Decay Time Cords has the effect of reversing the Percussion Decay Time knob. The decay time increases as the knob is turned up.

1. DC - Sets initial ramp Fast-Positive (+100)
2. Decay Knob - Inverted value slows ramp as the knob value is increased.
3. Ramp Out Cord - Inverts Ramp slope (downward).
4. Amp Vol - Initial setting is Off (-96dB). Ramp cannot overcome this negative bias.
5. Perc. Amt - When this knob is turned up, the positive bias on the Amp is restored so that so that the Ramp can now affect Amp Volume.
6. Volume Envelope - Fast Attack, Full Sustain, No Release

## Using the Modulation Processors

Modulation processors are inserted into a modulation routing as shown in the following diagram.

The modular analog synthesizers of yesteryear were incredibly flexible, partly because processing devices could be connected in any order. Modulation processors are designed according to this modular concept. They can be linked and used in a wide variety of ways limited only by your imagination. Consider the following example:

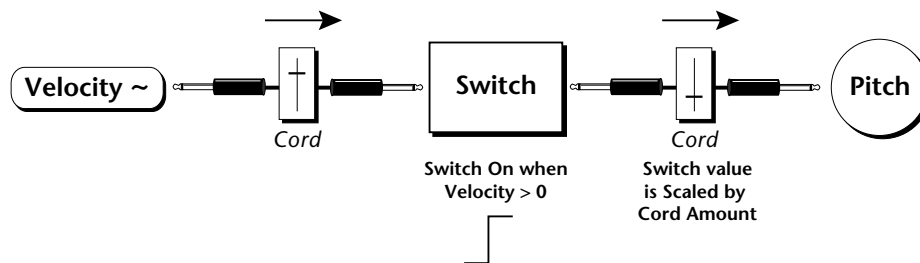

The patch illustrated above is programmed by setting the PatchCord screens as shown below.

|                 |      |
|-----------------|------|
| L1 PATCHCORD    | #01  |
| Vel+- -> Switch | +100 |

|                 |      |
|-----------------|------|
| L1 PATCHCORD    | #02  |
| Switch -> Pitch | +022 |

This particular modulation shifts the overall pitch up a fifth when the key velocity exceeds 64. Velocities below 64 play at normal pitch. Notes with velocities of 64 and above are raised a perfect fifth. The Velocity “~” source scales the played velocity around zero. In other words, low velocities (below 64) will have negative values and high velocities (64 and above) will be positive. A velocity of 64 would be zero. The Switch module only outputs a “1” if the input value is greater than zero. This digital “1” value can be scaled through the attenuator on the PatchCord to raise or lower the pitch by any amount. In this case, a scaling value of +22 raises the pitch by a perfect fifth. The amount of the PatchCord on the input to the switch is unimportant because ANY velocity value equal or greater than 64 will flip the switch. If the input PatchCord amount were a negative value however, the action of the velocity would be reversed and velocities less than 64 would raise the pitch and velocities equal or greater than 64 would play the original pitch.

But what if you want the velocity switch point to be something other than 64? Thanks to modulation processors, it can be done. Here's how.

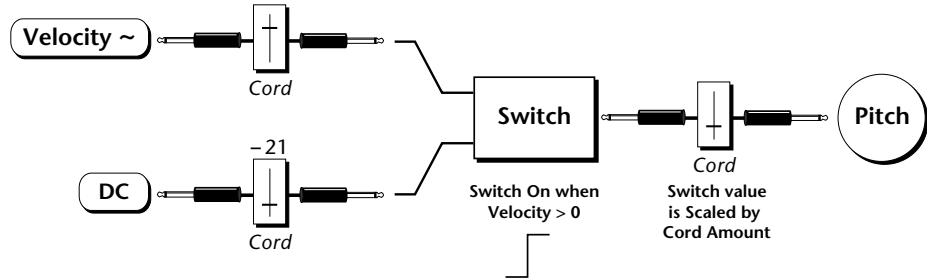

Connect the DC level to the input of the switch along with the velocity value. Note that more than one modulation source can be applied to the input of a processor.

DC offset adds a fixed value based on the PatchCord Amount setting. If applied to the switch along with the velocity, it changes the velocity value required to trip the switch. By setting the DC amount to a negative amount, higher velocity values are required to trip the switch. Setting the DC value to a positive value would bring the velocity switch point down. The PatchCord screens for this patch are shown below.

|                 |      |
|-----------------|------|
| L1 PATCHCORD    | #01  |
| Vel+- -> Switch | +100 |

|              |      |
|--------------|------|
| L1 PATCHCORD | #02  |
| DC -> Switch | -021 |

|                 |      |
|-----------------|------|
| L1 PATCHCORD    | #03  |
| Switch -> Pitch | +022 |

## More Examples

To derive a smooth random function you could route the Pink Noise generator through one of the Lag Processors. A smooth random wave is useful in small amounts to add a degree of natural variation to timbre when routed to filter cutoff. Normal pink noise is low pass filtered audio frequency noise with a 3 dB/octave slope to give equal energy per octave. Vintage Pro pink noise is actually more like very low frequency filtered noise, but it is perfect for use as a random control source.

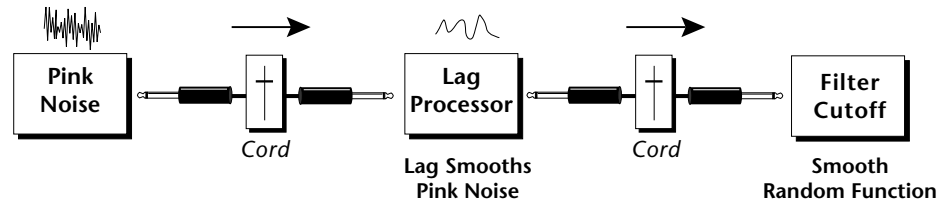

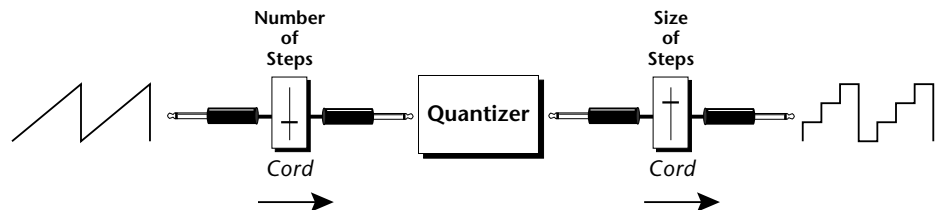

The **Quantizer** can generate interesting whole-tone scales when envelope generators or LFOs are routed to the input. The quantizer turns a smoothly changing input signal into a series of steps. By routing the output of the quantizer to Pitch and adjusting the PatchCord amounts, you can control both the number of steps and the pitch interval of each step.

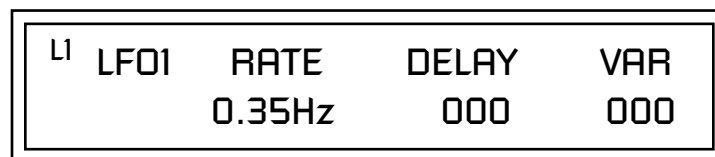
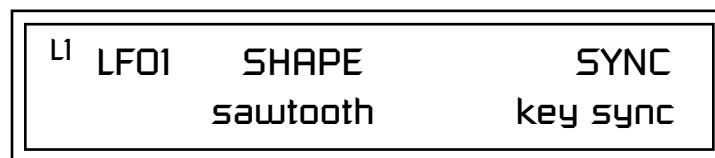

The input PatchCord amount controls how many steps will be generated. With a sawtooth wave (LFO+) feeding the input and the PatchCord amount set to 100%, sixteen steps are generated. The output PatchCord amount controls the size (or interval) of the steps.

Try setting up the following patch exactly as shown below using your favorite preset as a starting point.



 The 4x Amp can be used to get more steps or increase the interval of the Quantizer.

|       |             |      |
|-------|-------------|------|
| L1    | PATCHCORD   | #01  |
| LFO1+ | -> Quantize | +030 |

|          |           |      |
|----------|-----------|------|
| L1       | PATCHCORD | #02  |
| Quantize | -> Pitch  | +100 |

|    |           |      |
|----|-----------|------|
| L1 | PATCHCORD | #03  |
| DC | -> Pitch  | -050 |

 Experiment with this patch by connecting other sources and destinations to the Quantizer.

This patch generates an ascending arpeggio every time a key is pressed. A diagram of the patch is shown below. The patch is very straightforward except for the DC offset which was added to bring the pitch down into tune. (Sometimes you have to fix a problem, but using the mod processors there's usually a way around it to achieve the desired result.)

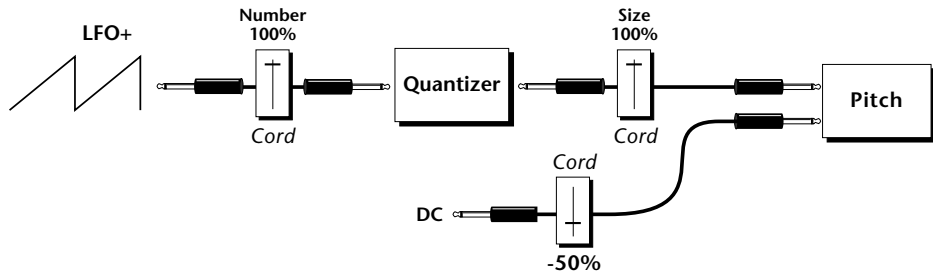

You can start to see some of the possibilities (and there are many). Whenever you find yourself wishing for some esoteric type of control, take a minute to think and see if there is a way to achieve the desired result using the modulation processors.

# Dynamic Filters

The block diagram of the Vintage Pro's signal path is shown below.

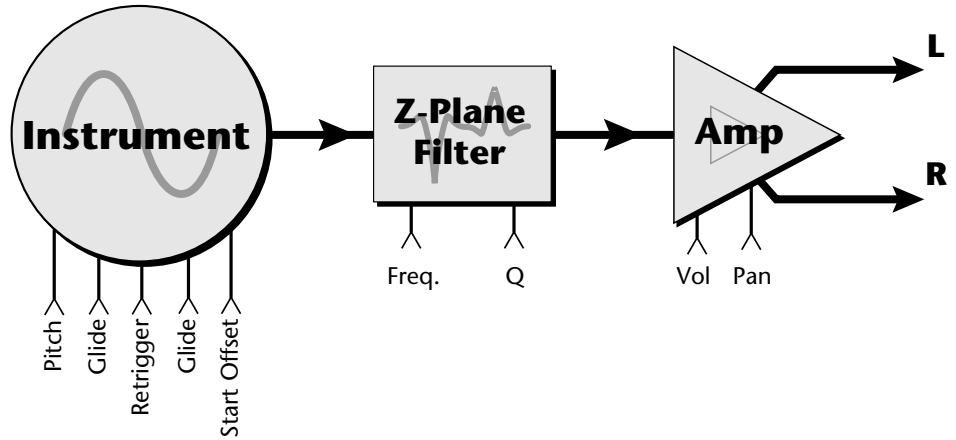

To understand how a filter works, we need to understand what makes up a sound wave. A sine wave is the simplest form of sound wave. Any waveform, except a sine wave, can be analyzed as a mix of sine waves at specific frequencies and amplitudes.

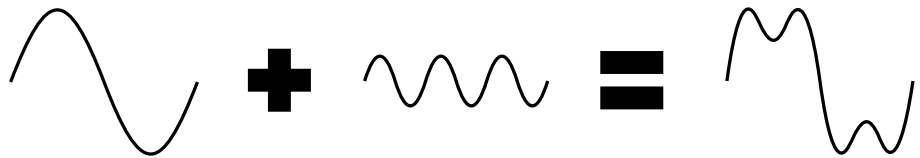

Any waveform can be analyzed as a mixture of sine waves.

One way to represent complex waveforms is to use a chart with frequency on one axis and amplitude on the other. Each vertical line of the chart represents one sine wave at a specific amplitude and frequency.

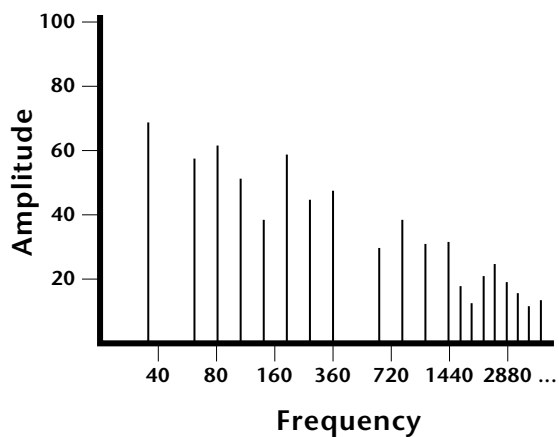

## What is a Filter?

Most sounds are complex waves containing many sine waves of various amplitudes and frequencies. A **filter** is a device which allows us to **remove certain components of a sound depending on its frequency**. For example, a *low-pass filter* lets the low frequencies pass and removes only the high frequencies as illustrated in the following diagram.

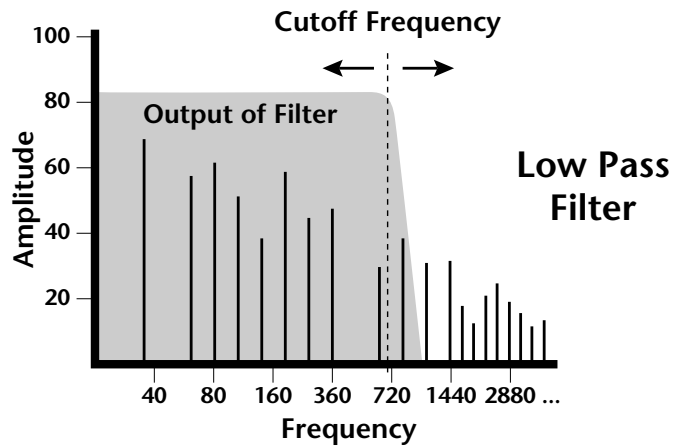

A filter that lets only the high frequencies pass is called a *high-pass filter* as illustrated in the following diagram.

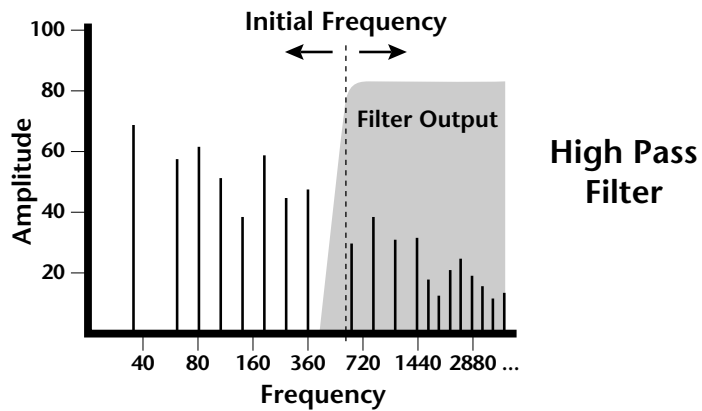



A filter which only lets a certain band of frequencies pass is called a *band-pass filter*.

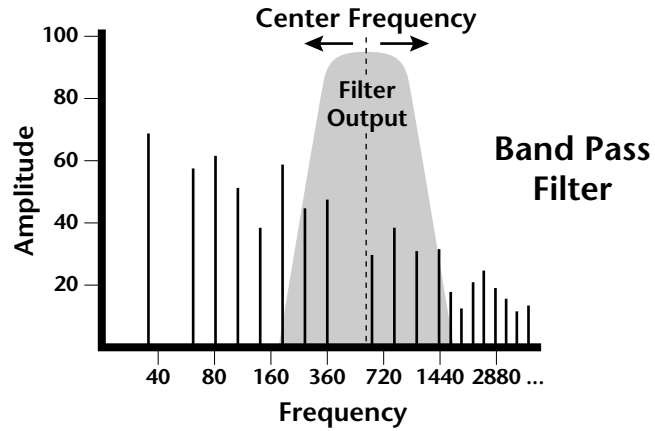

A *notch filter* is just the opposite of a band-pass filter and is used to eliminate a narrow band of frequencies.

Another control found on traditional filters is called Q or resonance. A lowpass filter with a high Q emphasizes the frequencies around the cutoff frequency. The following chart shows how different amounts of Q affect the low-pass filter response. In terms of sound, frequencies around the cutoff tend to "ring" with high Q settings. If a filter with high Q is slowly swept back and forth, various overtones are "picked out" of the sound and amplified as the resonant peak sweeps over them. Bells and gongs are real world examples of sounds which have a high Q.

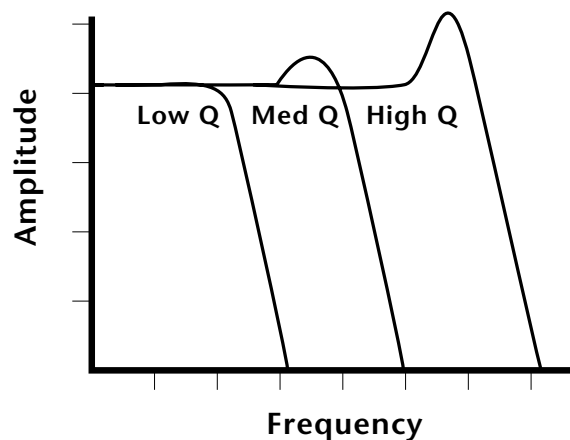

Another characteristic of a filter is the number of poles it contains. Traditional synthesizer filters were usually either 2-pole or 4-pole filters. The Vintage Pro has selectable 2, 4, and 6-pole low-pass filters. The number of poles in a filter describes the steepness of its slope. The more poles, the steeper the filter's slope and the stronger the filtering action. The tone controls on your home stereo are probably one-pole or two-pole filters. Parametric equalizers are usually either two-pole or three-pole filters.

In terms of vintage synthesizers, Moog and ARP synthesizers used 4-pole filters, Oberheim and E-MU synthesizers were famous for their 2-pole filter sound.

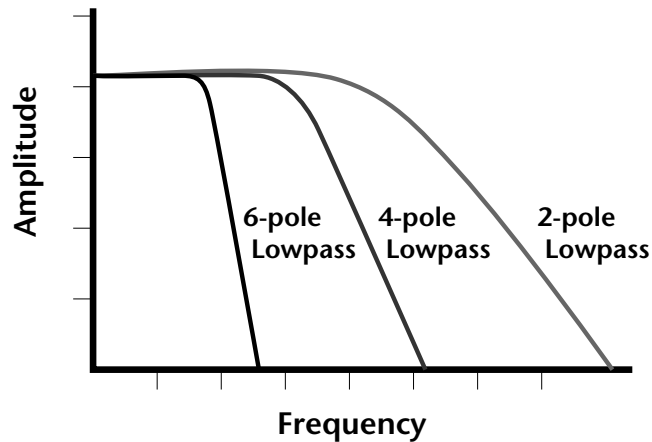

Using a filter, we have a way to control the harmonic content of a sound. As it turns out, even a simple low-pass filter can simulate the response of many natural sounds.

For example, when a piano string is struck by its hammer, there are initially a lot of high frequencies present. If the same note is played softer, there are fewer high frequencies generated by the string. We can simulate this effect by routing keyboard velocity to control the low-pass filter. The result is expressive, natural control over the sound.

If you use an envelope generator to control the cutoff frequency of a filter, the frequency content can be varied dynamically over the course of the note. This adds animation to the sound as well as simulates the response of many natural instruments.

## Parametric Filters

A more complex type of filter is called a parametric filter or *Swept EQ*. A parametric filter allows control over three basic parameters of the filter. The three parameters are: *Bandwidth*, *Frequency* and *Gain*. The Bandwidth allows you to select the width of the range of frequencies to be boosted or cut, the Frequency defines the center frequency of the bandwidth, and the Gain parameter either boosts or cuts the frequencies within the selected band by a specified amount. Frequencies not included in the selected band are left unaltered. This is different from a band-pass filter which attenuates (reduces) frequencies outside the selected band.

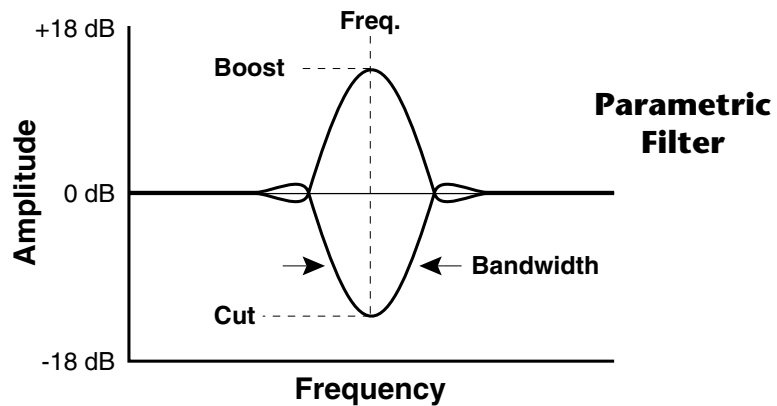

The parametric filter is quite flexible. Any range of frequencies can be either amplified or attenuated. Several parametric sections are often cascaded in order to create complex filter response curves.

If four parametric filter sections were cascaded, it would be possible to create the following complex filter response.

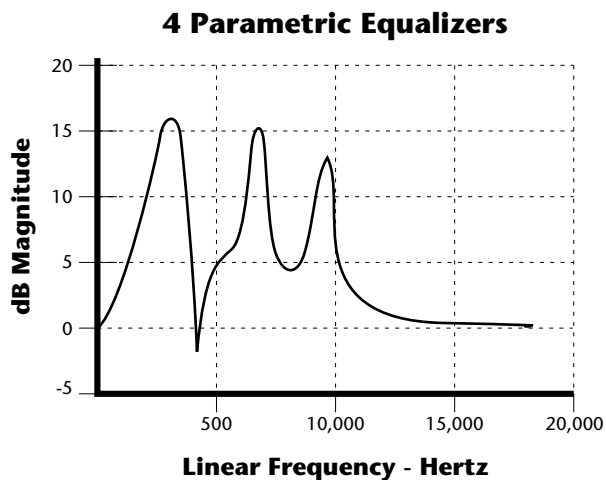

Many natural instruments have complex resonances which are based on their soundboard or tube size. The resonance shown above would be impossible to create using a normal synthesizer filter.

## The Z-Plane Filter

A Z-plane filter is a filter which can change its function over time. In a Z-plane filter, we start with two complex filter types and interpolate between them using a single parameter. See the following diagram.

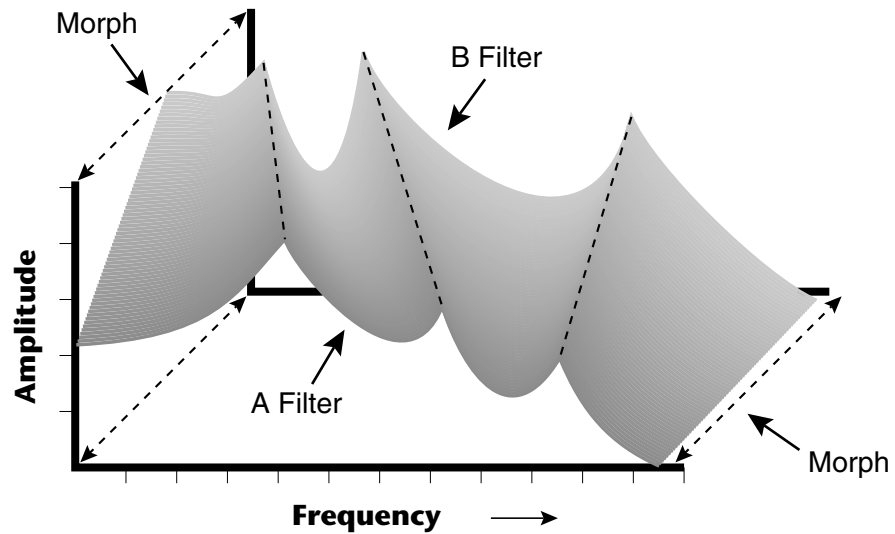

The Z-plane filter has the unique ability to change its function over time.

Filters A and B represent two different complex filters or “frames.” Changing a single parameter, the Morph, changes many complex filter parameters simultaneously. Following along the Morph axis you can see that the filter response smoothly interpolates between the two filters. This is the essence of the Z-plane filter. Through the use of interpolation, many complex parameters are condensed into one manageable entity.

Consider, as an example, the human vocal tract, which is a type of complex filter or resonator. There are dozens of different muscles controlling the shape of the vocal tract. When speaking, however, we don't think of the muscles, we just remember how it feels to form the vowels. A vowel is really a configuration of many muscles, but we consider it a single object. In changing from one vowel to another, we don't need to consider the frequencies of the resonant peaks. You remember the shape of your mouth for each sound and interpolate between them.

This Z-plane filter sweep can be controlled by an envelope generator, an LFO, modulation wheels or pedals, keyboard velocity, key pressure, and so on. In fact, any of the modulation sources can control the Z-plane filter.

Because creating the complex filtering is difficult and very time consuming, we have created 50 different types of filters and installed them permanently in ROM for your use. You simply select and use the filters in a manner similar to choosing an instrument. Because there are so many types of instruments and filters to choose from, the number of possible permutations is staggering.

## Signal Flow

Going back to the Signal Path diagram for a single channel we can reexamine the complete signal path.

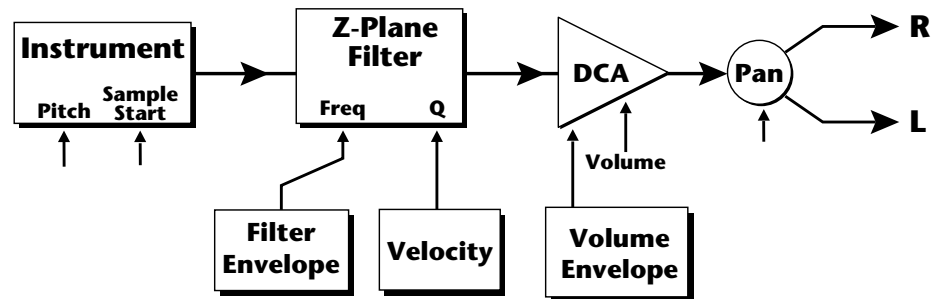

### Instrument

This is the sampled sound wave. The pitch of the instrument can be modulated by any modulation source. The sample start point can be changed only at the time the note is played.

### Z-Plane Filter

The Z-Plane Filter is used to shape the harmonic content of an instrument. The filter envelope is commonly used to shape the harmonic content dynamically over time but the filter frequency can be modulated by any source. The Q parameter can be modulated only at note-on time. There are 50 types of filters available. See “Vintage Pro Filter Types” on page 136 for a complete list of the filters.

### Digitally Controlled Amplifier (DCA)

Together with the Volume Envelope, the DCA is used to shape the volume contour of a sound. The DCA can be controlled by any modulation source. Velocity is often used as a modulation source for the DCA so that the harder you play, the louder the sound becomes.

### Pan

Adjusts the balance of sound to the left and right channels. Pan can be modulated by any modulation source.

## MIDI Channels & Real-time Controls

The MIDI real-time controllers may seem confusing at first, but they are really very simple once you understand them. You already know that there are 16 MIDI channels per MIDI cable. (*Vintage Pro has two MIDI input ports and so can accept a total of 32 MIDI channels.*) Each MIDI channel uses three basic types of messages; note on/off, preset changes, and continuous controller messages. Your MIDI keyboard, in addition to telling Vintage Keys which note was played, can also send real-time control information, which simply means control occurring in real-time or “live.” (You may be using a MIDI device other than a keyboard, but for simplicity's sake we'll presume that you *are* using a keyboard.) Real-time control sources include such things as pitch wheels or levers, modulation wheels or levers, control pedals and aftertouch and are used to add more expression or control.

Your MIDI keyboard sends out real-time controller information on separate continuous controller numbers. There is a set of 32 continuous controller numbers for each MIDI channel. Some of the controllers, such as the modulation wheel, volume, and pan have standardized numbers. For example, volume is usually sent on continuous controller #7. Your keyboard may have other real-time controls such as a control pedal or data sliders which can also be programmed to control the Vintage Pro.



The following MIDI controls are automatically routed in Vintage Pro:

|                    |     |
|--------------------|-----|
| Pitch Wheel        | pwh |
| Modulation Wheel   | 01  |
| Old DX7 Aftertouch | 03  |
| Pedal              | 04  |
| Volume             | 07  |
| Pan                | 10  |
| Expression         | 11  |

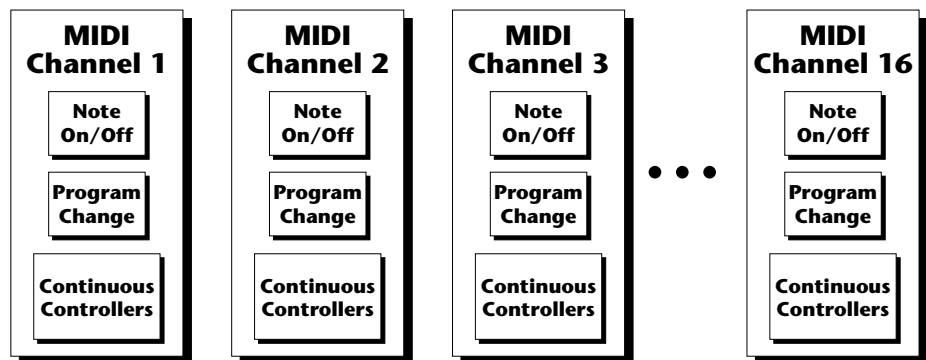

Any MIDI controller can be routed to any modulation destination. First, you have to know which controller numbers your keyboard transmits. Most modern MIDI keyboards let you select a controller number for each control on the keyboard. For example, it may let you select a number from 0-31 for the data slider. The realtime controller numbers that the keyboard transmits must match the numbers Vintage Pro is receiving, otherwise nothing will happen when you move the controls.

Suppose you wanted to send the four data sliders on your master keyboard. Vintage Pro can handle 12 MIDI controllers (A-L) of your choosing. “MIDI A-L” are simply names for the internal connections that link external MIDI continuous controllers to the PatchCord section of Vintage Pro. There are two parts to the connection. First, MIDI controller numbers are assigned to the letters A-L in the Master menu. Next, the letters A-L are connected to synthesizer control parameters in the PatchCord section of the Edit menu. The PatchCord Amount scales the amount of each controller by a positive or negative value.

The factory presets have the MIDI A-L controls connected to standard synthesizer functions (marked on the front panel of Vintage Pro). By choosing any four of the eight standard functions, your four sliders will work the same on every preset. The chart below shows how this might work if your keyboard transmitted the slider settings on MIDI controllers 12-15.

| Control  | MIDI Controller # | Routing | Standard Function         |
|----------|-------------------|---------|---------------------------|
| Slider 1 | 12                | A       | Controls Filter Frequency |
| Slider 2 | 13                | B       | Controls Filter Resonance |
| Slider 3 | 14                | G       | Controls Movement         |
| Slider 4 | 15                | L       | Controls FXB Amount       |

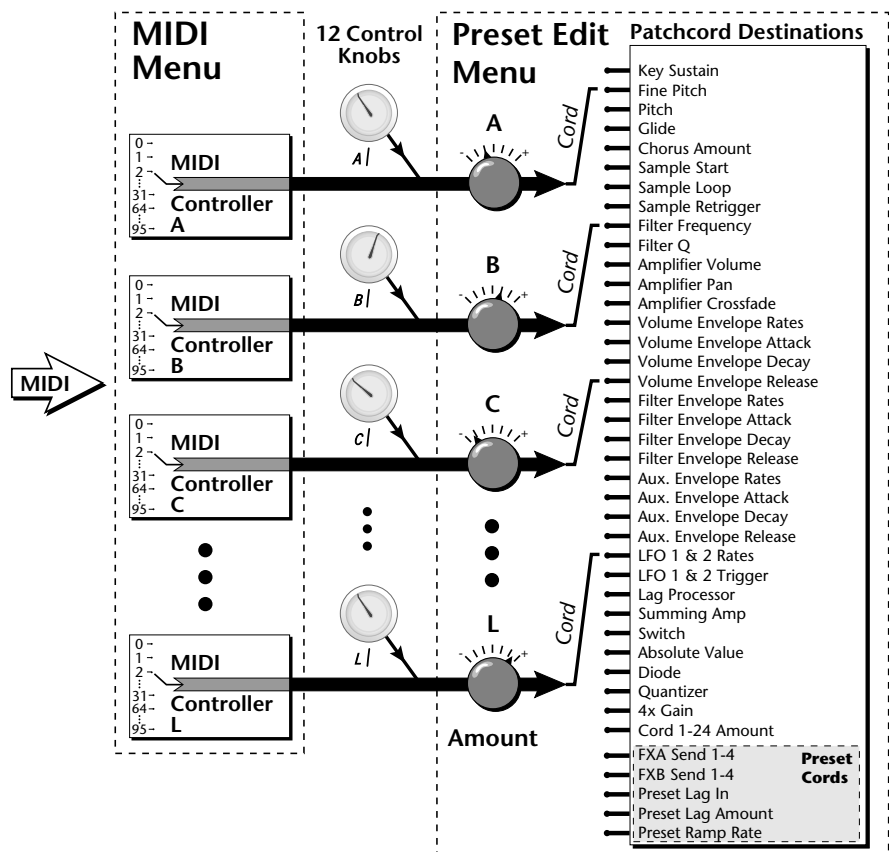

MIDI A-L are internal connections which simultaneously carry front panel controller knob data and MIDI continuous controller data.

The four controller knobs on the Vintage Pro front panel work just like MIDI real-time controllers. The four controller knobs are permanently assigned to controllers A-L. Pressing the control button adjacent to the row of knobs selects A-D, E-H or I-L functions for the knobs. The front panel knob (A-L) and incoming MIDI controller messages assigned to that letter, both control the same parameter that you select in the PatchCord screen.

## Bank Select Commands

When the original MIDI specification was developed, synthesizers had only 8 to 40 preset locations. At that time being able to select up to 128 presets didn't seem like much of a limitation. So it was that the original MIDI specification provided for the selection of up to 128 presets.

Musicians screamed "MORE" and so the MIDI specification was later amended to include **Bank Select Commands**. It was decided that Bank Select Commands would use Continuous Controllers 0 and 32 to allow the selection of up to 16,384 banks of 128 presets (over two million presets).

Because Bank Selects are implemented using Continuous Controllers, the Bank Selections can be made *per channel*. (This is getting better and better.) For each MIDI channel, you can select any of 16,384 banks and then one of the 128 presets in the bank. Of course no synthesizer has 16,384 banks (yet), but hey, it's nice to know it's possible (for that really BIG project).

Continuous Controller (CC) 0 is the MSB (most significant byte) and CC 32 is the LSB (least significant byte). Normally you send both the MSB and LSB controllers to implement a bank change.

Vintage Pro remembers the MSB and the LSB that were last sent (or last changed from the front panel). For example, if you have already set the Bank MSB to 18, you need only send the LSB to change banks within the Vintage Pro sound set. See the MIDI Bank Select chart below.

The selected bank remains selected until you change it (either via MIDI or by changing the bank from the front panel). Standard MIDI Program Change commands select from 128 presets within the selected bank.

 When you press the Audition button, the Bank Select MSB and LSB are displayed on the top line of the display.

| <b><u>MIDI BANK SELECT</u></b> |             |             |        |
|--------------------------------|-------------|-------------|--------|
|                                | <b>MSB</b>  | <b>LSB</b>  |        |
|                                | <b>cc00</b> | <b>cc32</b> |        |
| <b>USER</b>                    | 00          | 00          | Bank 0 |
| <b>USER</b>                    | 00          | 01          | Bank 1 |
| <b>USER</b>                    | 00          | 02          | Bank 2 |
| <b>USER</b>                    | 00          | 03          | Bank 3 |
| <b>VROM</b>                    | 18          | 00          | Bank 0 |
| <b>VROM</b>                    | 18          | 01          | Bank 1 |
| <b>VROM</b>                    | 18          | 02          | Bank 2 |
| <b>VROM</b>                    | 18          | 03          | Bank 3 |



## Stereo Mix Outputs

Vintage Pro has three sets of polyphonic stereo outputs (Main, Sub 1 and Sub 2). The channels used by a particular preset (or a particular MIDI channel) can be directed to appear at any one of these three stereo outputs. This feature is useful for adding signal processing (EQ, reverb, etc.) of individual sounds prior to final mixdown. By panning a preset completely left or right, it can be routed to a single output jack.

All presets are automatically routed to the Main outputs unless plugs are inserted into the Sub 1 or Sub 2 outputs.

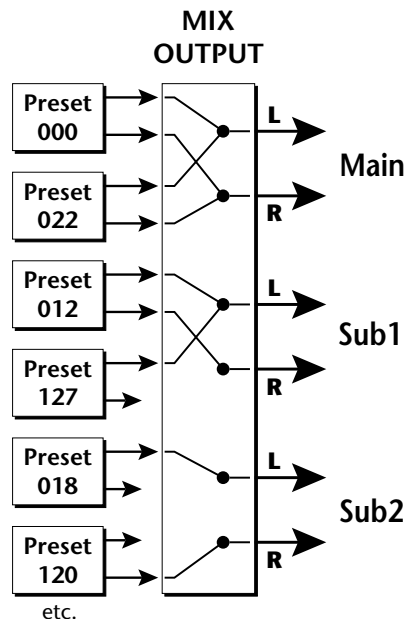

Each preset can be routed to one (and only one) set of stereo outputs. A preset can be routed to a single output using the pan control.

The routing can be performed according to MIDI channel from the Mix Output screen in the Master menu. Simply assign each channel to the desired output.

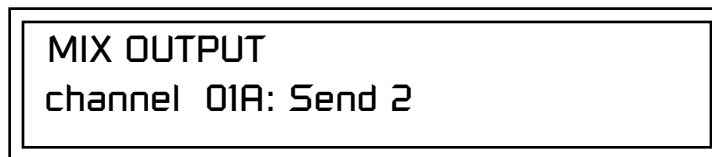

Sends DO NOT correspond to the same numbered Submix output numbers.

### SEND ROUTINGS

**Send 1** - Main Outputs

**Send 2** - Submix 1 (or Main Outs if no plug is inserted into Submix jack)

**Send 3** - Submix 2 (or Main Outs if no plug is inserted into Submix jack)

**Send 4** - Main Outputs

To route a particular preset to a Submix output, first go to the Mix Output screen in the Master menu and set the MIDI channel to "Preset".



Next set the Mix Output routing in the preset to the desired output (for each layer). Yes, you can send each layer to a different output if you want.

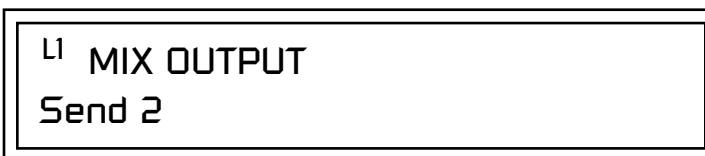

Why have a Send 4 routing at all if it only goes to the Main output? The answer lies in the dual function of the Sends. Sends can be used either as *Effect Sends* or as *External Output* routing busses. Send 4 is only used as an effect send, while Sends 2 and 3 can be used as effect sends **or** external routing busses.

By sending different amounts of presets to the effects, subtle or striking effects can be achieved using the two effect processors. This feature allows you to get the most out of two effects since you can have eight different mixes.

For more information, See "*Mix Output*" on page 66.

# Edit Menu



*While the Edit menu is activated, all incoming MIDI preset changes on the selected channel are ignored.*



*If there is no "A" option in the Layer field, you must enable the "Edit All Layers" function in the Master Menu.*

The Edit Menu contains four layers of preset parameters that you can modify and then save as preset information in one of the user preset locations.

There are four instrument layers in the Edit menu. See the illustration on page 115 for a description of the Preset Layer model.

## ► To Access the Edit Menu

Press the Edit button, lighting the LED. The Edit Menu screen displays the menu page most recently selected since powering up Vintage Pro. The cursor appears below the first character of the screen heading on line one.

## ► To Scroll through Layers

Place the cursor below the layer field. Rotate the Data Entry Control to select a layer (1-4).

You can also select **All Layers** by choosing "A" in the layer field. When All Layers is selected, the existing parameter value for any field will be displayed if the values of all four layers are equal. If the values of all four layers are NOT equal, the value of layer 1 will be displayed with flashing characters. If you change the parameter value, all layers will assume the new value and the display will stop flashing.

## ► To Scroll through Pages

Place the cursor below the page title field. This will automatically be done when you press the Home/Enter button. Rotate the Data Entry Control to scroll through the pages.

## ► To Change a Parameter

Place the cursor below the parameter field. Rotate the Data Entry Control to change the parameter value.

## Preset Name

The Preset names consists of two parts: a 3 letter preset category and a 12 letter preset name. Position the cursor under the character location and use the data entry control to change the character.

The preset category is used in conjunction with the Sound Navigator feature. Using the Sound Navigator, a category is selected and the presets in that category are listed in alphabetical order. Creating categories makes it easier to find specific sounds when you need them. For more information on Sound Navigator, see Sound Navigator in Chapter 2: Operations.



The keyboard can also be used to select character. The charts below show the keyboard character assignments.

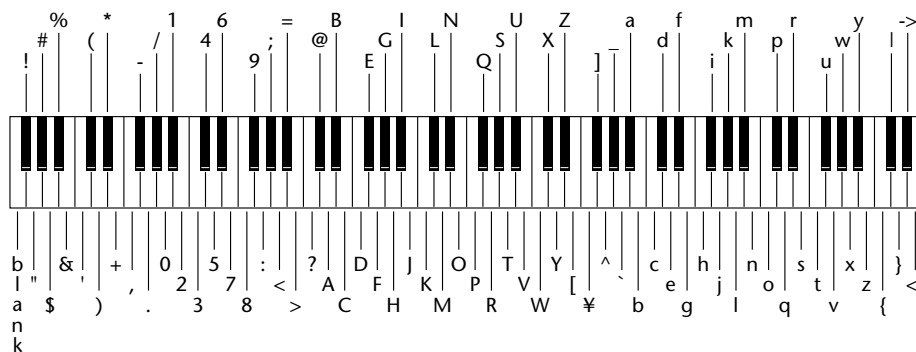

|    | C | C#  | D | D# | E | F     | F# | G | G# | A  | A# | B | Pitch |
|----|---|-----|---|----|---|-------|----|---|----|----|----|---|-------|
| -2 |   |     |   |    |   | blank | !  | " | #  | \$ | %  | & |       |
| -1 | ' | ( ) | * | +  | , | -     | .  | / | 0  | 1  | 2  |   |       |
| 0  | 3 | 4   | 5 | 6  | 7 | 8     | 9  | : | ;  | <  | =  | > |       |
| 1  | ? | @   | A | B  | C | D     | E  | F | G  | H  | I  | J |       |
| 2  | K | L   | M | N  | O | P     | Q  | R | S  | T  | U  | V |       |
| 3  | W | X   | Y | Z  | [ | ¥     | ]  | ^ | _  | `  | a  | b |       |
| 4  | c | d   | e | f  | g | h     | i  | j | k  | l  | m  | n |       |
| 5  | o | p   | q | r  | s | t     | u  | v | w  | x  | y  | z |       |
| 6  | { |     | } | →  | ← |       |    |   |    |    |    |   |       |

Octave

## Four Layer Architecture

Vintage Pro provides a 4 layer instrument structure. Each layer is a complete synthesizer voice with 50 filter types, over 64 modulation sources, more than 64 modulation destinations and 24 PatchCords to connect everything together. In addition, the four layers can be crossfaded or switched by key position, velocity or any real-time modulation source.

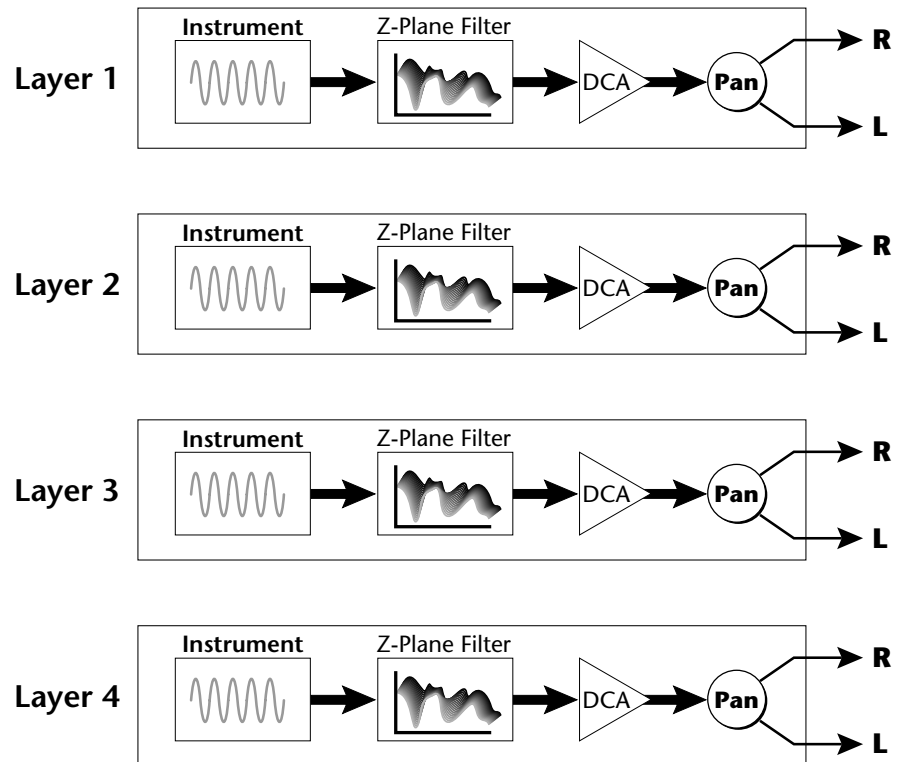

### Selecting Layers

In most of the Edit screens, the selected layer is shown in the upper left corner of the display. Layers 1-4 or All can be selected by positioning the cursor on this field and using the Data Entry Control to change the layer. In the screen shown below, Layer 1 is selected.

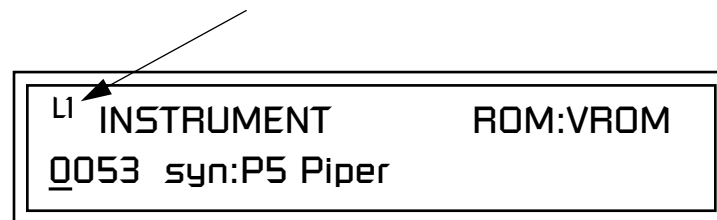

When "All Layers" (A) is selected, the existing parameter value for any field will be displayed if all layers are equal. If the layer parameter values are NOT equal, the value of Layer 1 will be displayed with flashing characters. If you move the Data Entry Control all values will be equal to this new value and the parameter value will no longer flash.

## Defining Layer Parameters

### Selecting an Instrument

The Edit menu parameters define the four layers and include the instrument assigned to the layer, the ranges of the layer, tuning, envelopes, filters, and patch cords. These parameters are defined for each layer on an individual basis (based on the currently selected layer). See “Common Preset Parameters” on page 147 for global preset settings.

The Instrument parameter defines which of the available instrument sounds is played by the current layer.

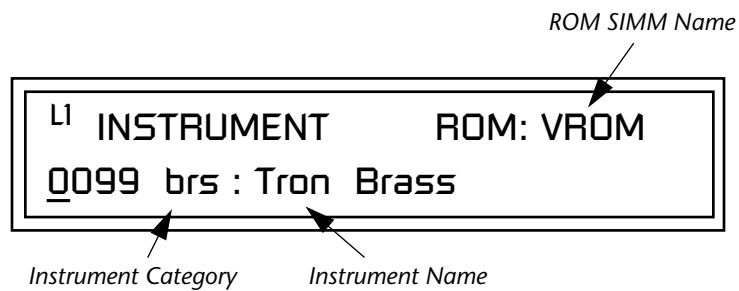

To select an instrument for the selected layer(s), move the cursor to the bottom line of the display and change the instrument using the Data Entry Control.

### Sound Navigator

Sound Navigator also works to help select Instruments although the category names are predefined. When the cursor is on the Instrument Category field, turning the Data Entry Control selects different instrument categories. The Name Field will change to show the first instrument in each category. Move the cursor to the instrument name to select instruments in the selected category.

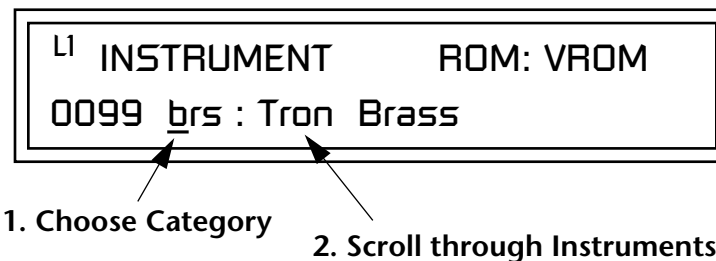

Selecting Categories of Instruments using Sound Navigator.

## Defining Key Range

The Key parameter defines the range on the keyboard used by the current layer. The Key range is from C-2 through G8.

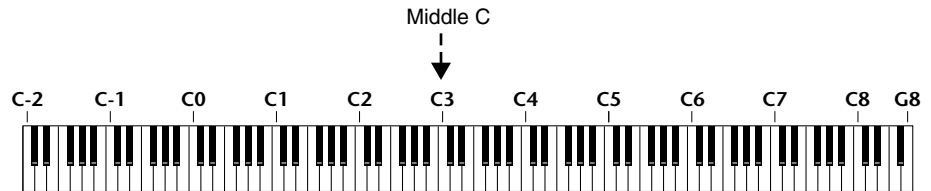

To define the range, set the low key value and the high key value.

You can select key numbers by simply pressing the desired keyboard key when the cursor is positioned on the low or high key field in the display.

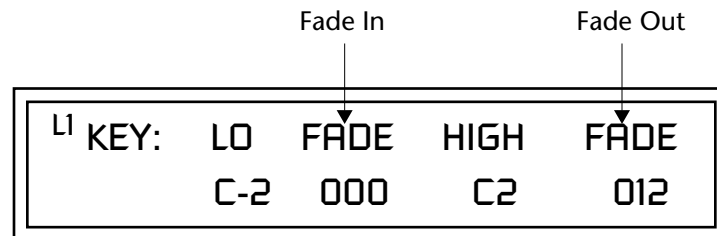

Layers can be crossfaded according to key position by adjusting the Low and High Fade parameters. The first Fade field determines how many semitones it takes the layer to Fade In from the low key. The second Fade field determines how many semitones it takes the layer to Fade Out to the high key. The screen shot above and the diagram below show Layer 1 being faded out over a one octave range.

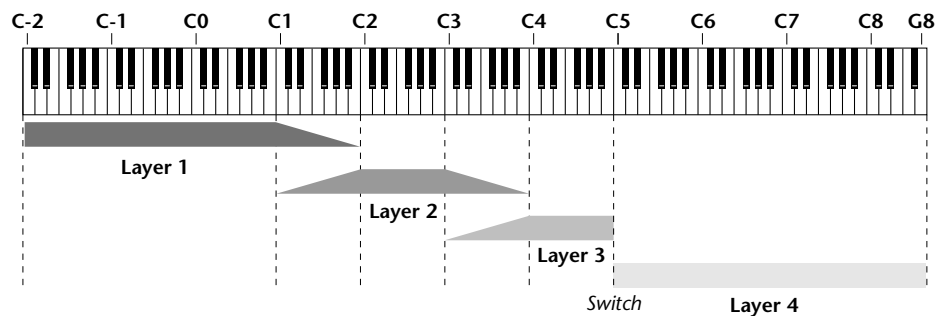

With a High Fade value of zero (as in layer 3 of the diagram), the layer simply switches off at the high key.

► To Switch Layers According to Key Position

The Key Range parameter allows you to create a “split” keyboard with up to four sounds adjacent to each other on the keyboard. This is shown in the diagram below.

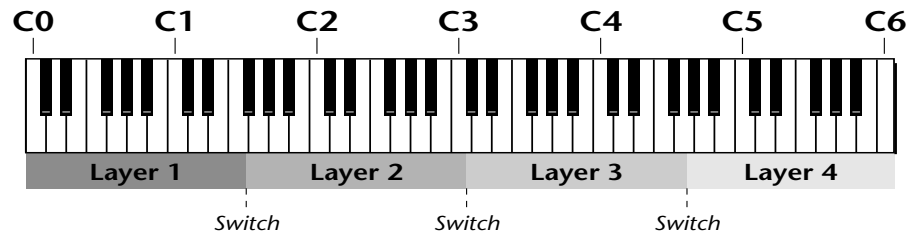

Just assign the low and high key range for each of the four layers with Fade set to zero. Set the Low and High Keys so they don't overlap other layers.

 You can select key numbers by simply pressing the desired keyboard key when the cursor is positioned on the low or high key field in the display.

|            |      |      |      |
|------------|------|------|------|
| L1 KEY: LO | FADE | HIGH | FADE |
| <u>C</u> 0 | 000  | F1   | 000  |

|             |      |      |      |
|-------------|------|------|------|
| L2 KEY: LO  | FADE | HIGH | FADE |
| <u>F</u> #1 | 000  | C3   | 000  |

|             |      |      |      |
|-------------|------|------|------|
| L3 KEY: LO  | FADE | HIGH | FADE |
| <u>C</u> #3 | 000  | F#4  | 000  |

|            |      |      |      |
|------------|------|------|------|
| L4 KEY: LO | FADE | HIGH | FADE |
| <u>G</u> 4 | 000  | C6   | 000  |

If two layers do overlap, both will play as shown in the next example.



► **To Stack Layers**

If the ranges of two or more Layers overlap it is called *stacking layers*. All Layers assigned to a key sound when the key is played. This is shown in the following diagram. It's very easy to stack layers. Simply duplicate the key ranges for any layers you want to stack.

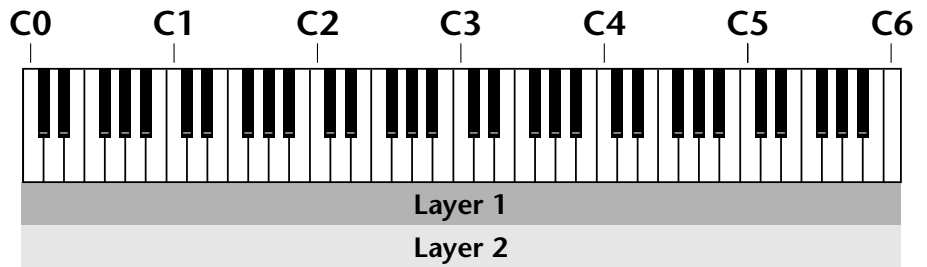

|                     |            |      |      |      |
|---------------------|------------|------|------|------|
| L <sup>1</sup> KEY: | LO         | FADE | HIGH | FADE |
|                     | <u>C</u> 0 | 000  | C6   | 000  |

|                     |            |      |      |      |
|---------------------|------------|------|------|------|
| L <sup>2</sup> KEY: | LO         | FADE | HIGH | FADE |
|                     | <u>C</u> 0 | 000  | C6   | 000  |

## Defining the Velocity Crossfade Range

Velocity is a measure of how hard the key is pressed. Velocity Range lets you control the volume of the layers using velocity. Using this function you can crossfade or cross-switch between layers according to how hard you play the keyboard.

Set the velocity range of the layer by defining the high and low velocity values. Values range from 0 (off) to 127 (hardest).

|                     |           |      |      |      |
|---------------------|-----------|------|------|------|
| L <sup>2</sup> VEL: | LO        | FADE | HIGH | FADE |
|                     | <u>36</u> | 012  | 96   | 012  |

The Fade fields define the velocity crossfade range for the currently selected layer. The first Fade field defines the Fade In range for the low velocity value. The second defines the Fade Out range for the high velocity value.

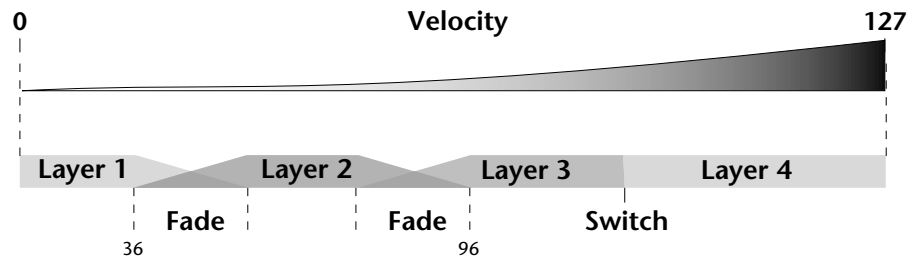

With soft playing, Layer 1 sounds. As you play harder, Layer 1 gradually fades out and Layer 2 fades in. When the keyboard is played hard, Layer 3 plays.

► To Set Up a Velocity Crossfade Between Layers

Set the velocity fades so that layer 1 fades out with higher key velocity, while layer 2 fades in. At a velocity of 64, the two sounds are equal volume. You may want to adjust the fade in and fade out points to achieve a natural sounding crossfade. These parameters vary depending on the sounds.

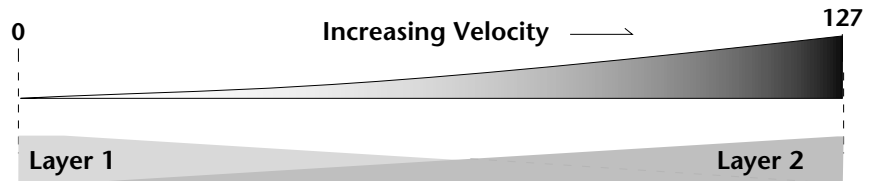

|                     |            |      |      |      |
|---------------------|------------|------|------|------|
| L <sup>1</sup> VEL: | LO         | FADE | HIGH | FADE |
|                     | <u>000</u> | 000  | 127  | 127  |

|                     |            |      |      |      |
|---------------------|------------|------|------|------|
| L <sup>2</sup> VEL: | LO         | FADE | HIGH | FADE |
|                     | <u>000</u> | 127  | 127  | 000  |

## Defining the Real-time Crossfade Range

The Real-time Crossfade window lets you control the volume of the four layers using a real-time controller such as a front panel knob, a pedal or an LFO or Envelope generator. The controller is defined by the PatchCord parameter (see “PatchCords” on page 143).

The Fade fields define the crossfade range in velocity for the currently selected layer. The first Fade field defines the Fade In amount for the low Real-time Control value. The second defines the Fade Out amount for the high Real-time Control value. The Fade value range is from 0 to 127.

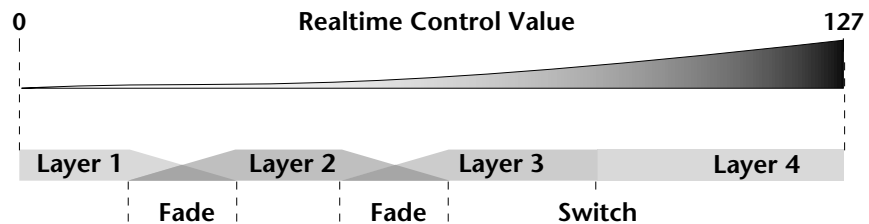

After the Ranges and Fades have been adjusted for each layer in the Real-time Crossfade screen, you must assign a real-time controller to RTXfade (Real-time Crossfade) on each Layer in the PatchCord screen. Set the PatchCord Amounts to +100.

### ► To Set Up a Real-time Crossfade Between Two Layers

As the real-time control (knob, pedal, LFO, etc.) is increased, Layer 1 fades out as Layer 2 fades in. This example only uses two of the possible four layers. Refer to the screen diagrams below.

|    |     |     |      |      |      |
|----|-----|-----|------|------|------|
| L1 | RT: | LO  | FADE | HIGH | FADE |
|    |     | 000 | 000  | 127  | 127  |

|    |     |     |      |      |      |
|----|-----|-----|------|------|------|
| L2 | RT: | LO  | FADE | HIGH | FADE |
|    |     | 000 | 127  | 127  | 000  |

1. Select a preset.
2. Press the Edit button to access the Edit menu.
3. Go to the Instrument page and select instruments for Layers 1 and 2.

4. Press Enter, then use the Data Entry Control to advance to the Real-time Crossfade page.
5. Define the High and Low range of each Layer. In this example the entire range of 0-127 is used.
6. Define the Fades for each Layer. This is just an initial setting. The Range and Fade parameters may have to be adjusted later to get a smooth crossfade.
7. Press Home/Enter and use the Data Entry Control to advance to the PatchCord page. Select Layer 1.
8. Select the modulation source for the crossfade (knob, pedal, LFO, Envelope) and set the destination to RTXfade. Set the Cord Amount to +100.
9. Select Layer 2. Select the same source and destination for the crossfade and set the Cord Amount to +127.

|                  |      |
|------------------|------|
| L1 PATCHCORD     | #01  |
| MidiA -> RTXfade | +100 |

10. Play the keyboard while adjusting the real-time controller. Go back to the Real-time Crossfade screens to fine tune the crossfade if necessary. Decreasing the fade size will narrow the region where both layers are sounding.

► **To Randomly Cross-Switch Between Four Layers**

In certain situations, you may want to switch between several layers randomly. **Crossfade Random** is a modulation source specifically designed to handle this situation. Unlike the other random sources, Crossfade Random generates one random number for all layers each time a key is pressed.

To set up a four layer Cross-Switch, simply assign each of the four layers to a different Real-time Crossfade range, then assign XfdRnd to RTXfade in the PatchCords for each layer.

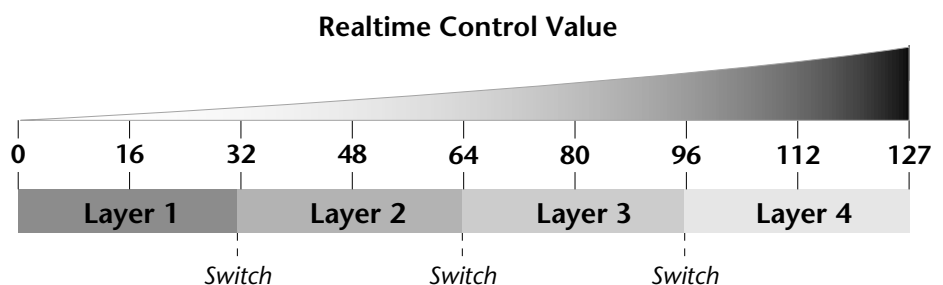

1. Press the Edit button to access the Edit menu.
2. Go to the Instrument screen and select Instruments for Layers 1 through 4.
3. Press Enter, then use the Data Entry Control to advance to the Real-time Crossfade page.

|    |     |     |      |            |      |
|----|-----|-----|------|------------|------|
| L1 | RT: | LO  | FADE | HIGH       | FADE |
|    |     | 000 | 000  | <u>031</u> | 000  |

|    |     |            |      |      |      |
|----|-----|------------|------|------|------|
| L2 | RT: | LO         | FADE | HIGH | FADE |
|    |     | <u>032</u> | 000  | 063  | 000  |

|    |     |            |      |      |      |
|----|-----|------------|------|------|------|
| L3 | RT: | LO         | FADE | HIGH | FADE |
|    |     | <u>064</u> | 000  | 095  | 000  |

|    |     |             |      |      |      |
|----|-----|-------------|------|------|------|
| L4 | RT: | LO          | FADE | HIGH | FADE |
|    |     | 09 <u>6</u> | 000  | 127  | 000  |

4. Define the High and Low range of each Layer as shown above.
5. Press Home/Enter and use the Data Entry Control to advance to the PatchCord page. Select Layer 1.
6. Select XfdRnd as the modulation source and RTXfade as the destination. Set the Cord Amount to +100.
7. Repeat step 6 for the remaining three layers.

*Transposing the Instrument*

```
L1 PATCHCORD #01
XfdRand -> RTXfade +100
```

8. That's it! Now set each Layer up the way you want. Try radically different instruments, filter settings, or tunings. Or you can make each layer just slightly different for a more natural effect. Try adjusting the Fades or overlapping the ranges if you want more than one layer to play at once.

The Transpose parameter lets you transpose the key of the current layer's Instrument. Transpose works by shifting the keyboard position in semitone intervals relative to middle C. Use this parameter to transpose different layers apart by semitone intervals. For example, by transposing one layer by +7 semitones, it will track other layers at a perfect fifth interval.

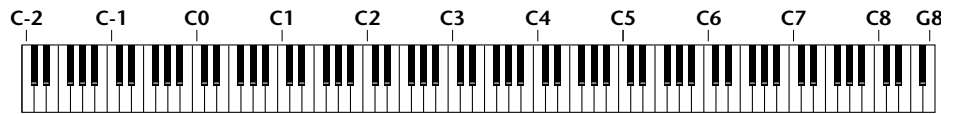

The range of transposition is -36 to +36 semitones.

```
L1 TRANSPOSE
+36 semitones
```

## Tuning

The Tuning parameter changes the pitch of the key in semitone and 1/64 semitone intervals.

|                   |     |       |     |
|-------------------|-----|-------|-----|
| L1 <u>T</u> UNING |     |       |     |
| Coarse:           | +36 | Fine: | +63 |

Use the Coarse field to shift the tuning by semitone intervals. Use the Fine field to shift tuning by 1/64 semitones (or 1.56 cents) intervals.

### Background: Transpose vs. Coarse Tuning

Transpose works by shifting the keyboard assignment of the Instrument (as if you were sliding the keyboard up and down with the Instrument remaining in the same position). Coarse Tuning keeps the instrument placement on the keyboard and actually tunes the samples up using a digital process called interpolation. Use Course Tuning on drum instruments to change the pitch while keeping sample placement constant. Coarse Tuning can also be useful to slightly change the timbre of the instrument.

## Amplifier

This parameter sets the initial volume and pan position of the current layer. These values can be changed using any Real-time Controller set up in the PatchCords. The value range for the volume is from -96 dB to +10 dB. 0 dB is the default setting. Routinely turning the volume up to +10 dB is not recommended because it doesn't allow other modulation sources to increase the volume further.

|                      |       |      |     |
|----------------------|-------|------|-----|
| L1 <u>A</u> MPLIFIER |       |      |     |
| Volume:              | +10dB | Pan: | 48L |

This field determines the initial Pan value for the current layer. The value range for Pan is from 64L to 0 (left) and 0 to 63R (right). Pan adjusts the volume into the left and right output channels relative to the Pan setting in the main Preset Select screen (see "Channel Pan" on page 27). So, if you, for example, set the Pan value in the Preset Select screen to 64L and set this Pan value to 63R, the actual pan amount would be 0 as these two pan parameters are relative to each other.



## Volume Envelope

 *Factory Mode is useful for Instruments containing multiple drums, since each drum can have its own envelope settings.*

 *If two adjacent segments have the same level in a “time-based” envelope, the segment will be skipped. Adjacent segments must have different levels for the rate control to work.*

An envelope can be described as a “contour” which is used to shape the sound over time. The *Volume Envelope* controls the volume of the sound in the current layer over time. The way the volume of a sound evolves has a profound effect on how we perceive the sound.

Each instrument has its own Factory preset Volume Envelope setting. The Volume Envelope allows you to program your own envelope settings.

### Selecting the Mode

The Mode field determines whether the layer will use the instrument’s default envelope (Factory) or use the user-programmed Volume Envelope. There are three mode options and repeat.

- **Factory:** Uses the factory preset envelope contained in each instrument. If you select the “Factory” mode, the Volume Envelope parameters are disabled and the factory defined settings are used instead.

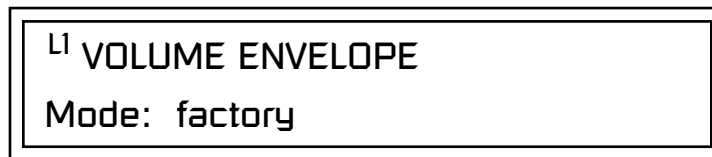

- **Time-based:** Defines the Volume Envelope rates from 0 to 127 (approximately 1 ms to 160 seconds). The Master clock has no affect on time-based rates.
- **Tempo-based:** The Volume Envelope times vary based on the master tempo setting. Note values are displayed instead of a number when the time corresponds to an exact note value. Tempo-based envelopes are useful when using external sequencers and arpeggiators because the envelope rates compress and expand according to the Master Tempo setting, keeping the envelopes in sync with the sequence or arpeggio.

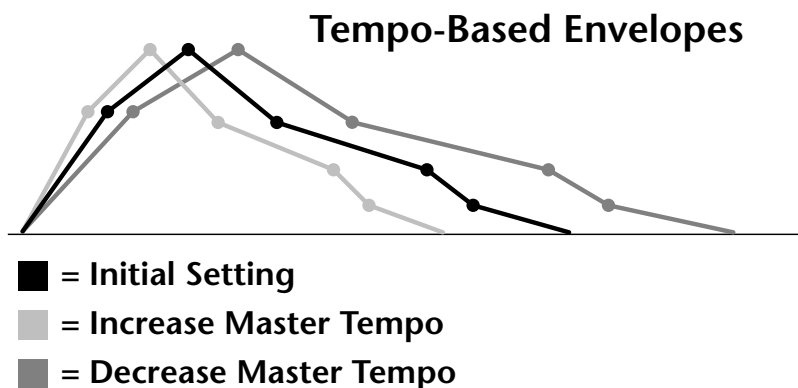

Tempo-based envelope rates change according to the Master Tempo rate.

 See the Programming Basics section of this manual for detailed information about how the Envelopes work.

### Defining the Volume Envelope

The Volume Envelope controls the volume of the layer over time. The Volume Envelope has six stages to the contour: Attack 1, Attack 2, Decay 1, Decay 2, Release 1 and Release 2. When a key is pressed, the Envelope goes through the first four stages. If you continue to hold down the key, the envelope holds at the Decay 2 level. When the key is released, the envelope continues through the Release stages ending at the Release 2 level.

| L1 | VOL ENV          | RATE | LEVEL |
|----|------------------|------|-------|
|    | <u>A</u> ttack 1 | 84   | 100%  |

As soon as the Attack 1 level is reached, the Attack 2 phase begins. When the Attack 2 Level is reached, the Decay 1 phase begins. When the key is released, the envelope immediately jumps to the Release 1 stage, then the Release 2 stage finally ending at the Release 2 level.

If you have selected the factory mode, the Volume Envelope parameter screen looks like the following illustration.

| L1 | VOL ENV                  | RATE | LEVEL |
|----|--------------------------|------|-------|
|    | (using factory envelope) |      |       |

 If the Release 2 level is set at a value other than zero, the note will continue to sound after the key is released. This might be useful for drone effects, but the channel won't stop sounding until all channels are used up.

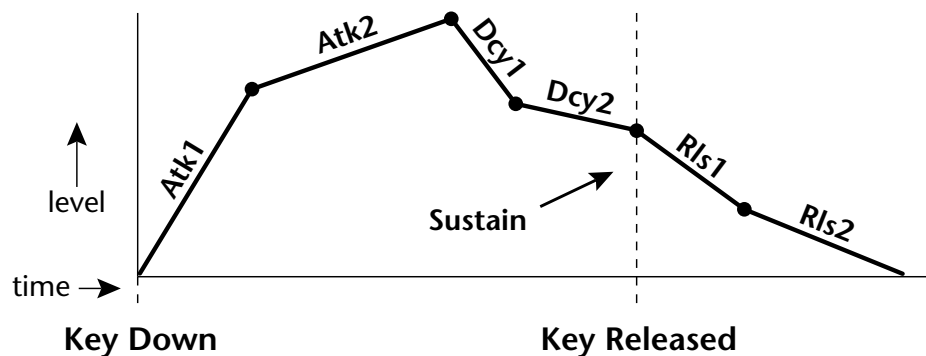

On the Volume Envelope, levels can only be set to positive values. The value range is from 0 to +100.

## Chorusing the Layer



**WARNING:** Because it works by doubling instruments, Chorusing halves the number of notes you can play.

Chorusing “thickens” the sound by doubling the sound in stereo and then detuning it. Every layer with chorus turned on uses twice the polyphony for that layer.

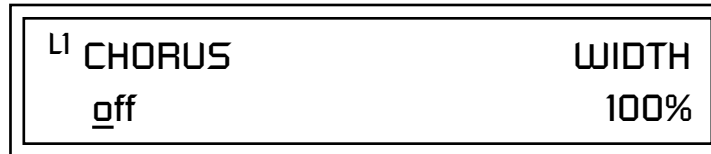

The first field in this screen turns Chorus On or Off and allows you to adjust the amount of detuning (1 to 100%). The *Width* parameter controls the stereo spread. 0% reduces the chorus to mono and 100% provides the most stereo separation.

## Sound Start Offset and Delay

**Sound Start** sets where the instrument begins playing when you hit a key. Setting the Start Offset amount to “0” plays the sample from the beginning. Higher values move the Sample Start Point further into the sample toward the end. There is also a PatchCord source which can be used to change the Sound Start point at note-on time.

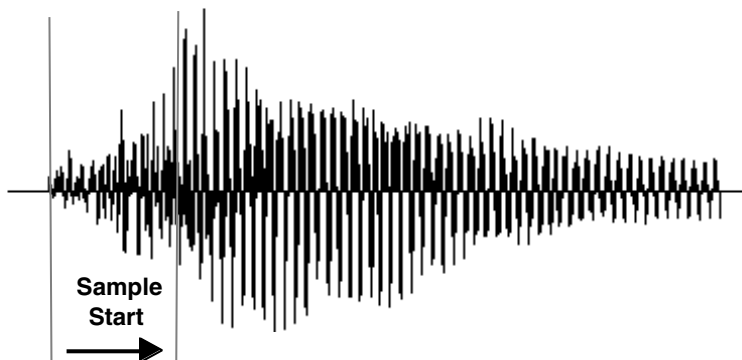
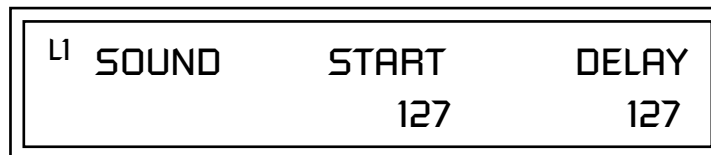

Controlling the Sound Start using Key Velocity (< Amt -) brings in the attack of the wave only when you play hard. This is especially effective with percussion instruments.

**Delay** defines the time between when you hit a key (note-on) and the onset of the current layer’s note and the start of the envelopes (if applicable). Delay values below zero are *Tempo-based* values, meaning the time is based on the Master Tempo setting. Note values are displayed by adjusting the Delay Time value below zero. The sound will be delayed by the selected note value based on the master clock.

## Non-Transpose Mode

This function turns keyboard transposition On or Off for the current layer. With Nontranspose “on,” the keyboard will not control the pitch of the instrument. This is a useful function for drones, attack “chiffs,” or other sound effects which you may not want to track the keyboard.

L1 NONTRANSPOSE  
off

## Solo Mode

Provides the playing action of a monophonic instrument such as a lead synthesizer by preventing more than one note from sounding at once. There are eight different solo modes provided. Try setting up different layers with different solo mode and glide rates or combine solo mode with polyphonic playing modes.

L1 SOLO MODE  
synth (low)



In order to define a monophonic glide (see the Portamento parameter), you must be in Solo mode.

The Solo modes are:

**Multiple Trigger:** Last note priority. No key-up action. Retrigger envelopes and samples when a key is pressed.

**Melody (last):** Last note priority. No key-up action.

*First solo note:* Envelopes start at Attack segment from zero. Samples start at the beginning.

*If previous note is releasing:* Envelopes start at Attack segment, but from current level. Samples start at the beginning.

*When playing “Legato”:* Envelopes continue from current segment and level. Samples start at the loop or the beginning if unlooped.

**Melody (low):** Same as Melody (last), but with low note priority. Newly played keys which are higher than the lowest solo key held do not sound.

**Melody (high):** Same as Melody (last), but with high note priority. Newly played keys which are lower than the highest solo key held do not sound.

**Synth (last):** Similar to Melody (last) but this mode has key-up action. When you release the currently sounding solo key while holding other keys down, the highest held solo key sounds in a Legato fashion.

## Assign Group

**Synth (low):** Same as Synth (last) but with low note priority. When you release the currently sounding solo key while holding other keys down, the lowest held solo key sounds in a Legato fashion (MiniMoog).

**Synth (high):** Same as Synth (last) but with high note priority. When you release the currently sounding solo key while holding other keys down, the highest held solo key sounds in a Legato fashion.

**Fingered Glide:** Same as Synth (last), except that Glide is disabled when playing Staccato, enabled when playing Legato.

Use the Assign Group parameter to assign a certain number of channels to each layer. By assigning all voices in the preset to assign groups, important parts are protected from being “stolen” by more recently played keys. Or you can assign a voice, such as an open high hat, to a mono channel so it is cancelled by a closed high hat on the same mono channel. Layers rotate within their assigned “bin” of channels, not interfering with other bins.



The modes are:

**Poly All:** Notes are played polyphonically with dynamic channel assignment using all 32 channels.

**Poly 16 A-B:** Two bins of 16 channels each. Notes are played polyphonically with dynamic channel assignment using no more than 16 channels.

**Poly 8 A-D:** Four bins of 8 channels each. Notes are played polyphonically with dynamic channel assignment using no more than 8 channels each.

**Poly 4 A-D:** Four bins of 4 channels each. Notes are played polyphonically with dynamic channel assignment using no more than 4 channels each.

**Poly 2 A-D:** Four bins of 2 channels each. Notes are played polyphonically with dynamic channel assignment using no more than 2 channels each.

**Mono A-I:** Nine monophonic channels, Any layers assigned to the same letter interrupt each other without affecting other layers.

## Glide

Glide creates a smooth transition from one note to the next instead of the normal instantaneous change in pitch when a new key is pressed. This effect is commonly heard on slide guitars, synthesizers and violins.

|           |                   |              |
|-----------|-------------------|--------------|
| <b>L1</b> | <b>GLIDE RATE</b> | <b>CURVE</b> |
|           | 0.000 sec/oct     | linear       |

The **Glide Rate** parameter defines the time it takes to glide to the new pitch (the larger the value, the slower the glide rate) The glide rate value range is from 0 through 32.738 seconds (zero means off).

The **Glide Curve** describes how the glide accelerates as it slides between notes. Because of the ear's non-linear response to pitch, a linear glide sounds slow at the beginning and speeds up toward the end. Exponential curves actually sound smoother and more linear. Eight exponential curves are provided. Choose one that suits your style.

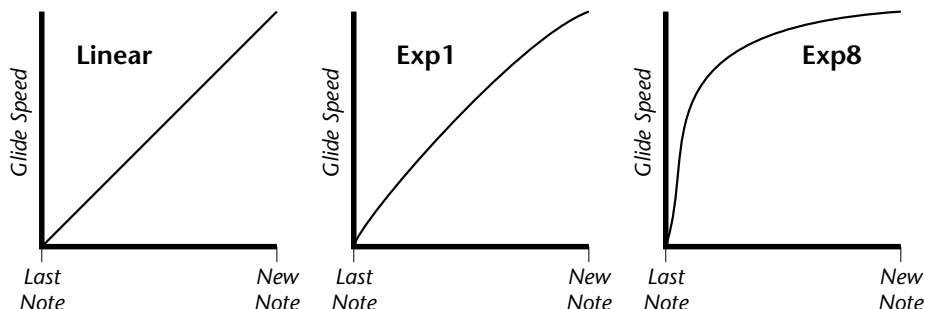

Glide can be either polyphonic or monophonic depending of the state of *Solo Mode*.

## Z-Plane Filters

A filter is a device which changes the output of a signal (sound) by removing certain elements of the signal based on the frequency and amplitude. The "Order" of a filter defines the number of filter elements it contains. The more elements, the more complex the filter.

Vintage Pro contains 50 different types of E-MU's celebrated Z-plane filters. In addition to the standard Low pass, High pass and Band pass filters, Vintage Pro contains Swept Octave Equalizers, Phasers, Flangers, Vocal Formant Filters, and digital models of classic synthesizer filters.

In the filter chart below you will notice that the "Order" of the filters varies from 2nd to 12th order. Higher order filters have more sections and can produce more complex formants. Vintage Pro's filter chips can implement

128 filters of 2nd to 6th order complexity or 64 filters of 12th order complexity. Therefore, if you decided to use all 12th order filters, Vintage Pro would be limited to 64 voices. Filters are dynamically allocated according to their usage so that the maximum number of voices is always available. See page 102 for more information about filters.

### Filter Types

This screen allows you to choose the type of filter for the current layer.

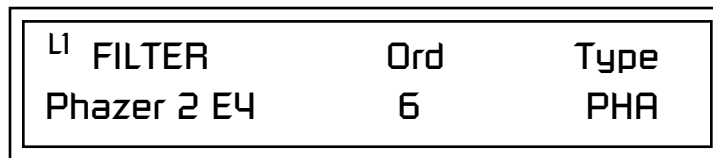

| Filter Types |                   |
|--------------|-------------------|
| LPF          | Low-pass filter   |
| HPF          | High-pass filter  |
| BPF          | Band-pass filter  |
| EQ+          | EQ boost          |
| EQ-          | EQ cut            |
| VOW          | Vowel / formant   |
| PHA          | Phaser            |
| FLG          | Flanger           |
| REZ          | Special resonance |
| WAH          | Wah-wah           |
| DST          | Distortion        |
| SFX          | Special Effect    |

| Filter Name | Order | Type | Description   |
|-------------|-------|------|---|
| Smooth      | 02    | LPF  | Typical OB type low-pass filter with a shallow 12 dB/octave slope.                                    |
| Classic     | 04    | LPF  | 4-pole low-pass filter, the standard filter on classic analog synths. 24 dB/octave rolloff.           |
| Steeper     | 06    | LPF  | 6-pole low-pass filter which has a steeper slope than a 4-pole low-pass filter. 36 dB/octave rolloff! |
| MegaSweepz  | 12    | LPF  | “Loud” LPF with a hard Q. Tweeters beware!  |
| EarlyRizer  | 12    | LPF  | Classic analog sweeping with hot Q and Low end.   |
| Millennium  | 12    | LPF  | Aggressive low-pass filter. Q gives you a variety of spiky tonal peaks.                               |
| KlubKlassik | 12    | LPF  | Responsive low-pass filter sweep with a wide spectrum of Q sounds                                     |
| BassBox-303 | 12    | LPF  | Pumped up lows with TB-like squelchy Q factor.  |
| Shallow     | 02    | HPF  | 2-pole high-pass filter. 12 dB/octave slope.  |
| Deeper      | 04    | HPF  | Classic 4-pole high-pass filter. Cutoff sweep progressively cuts 4th Order High-pass.                 |
| Band-pass1  | 02    | BPF  | Band-pass filter with 6 dB/octave rolloff on either side of the passband and Q control.               |
| Band-pass2  | 04    | BPF  | Band-pass filter with 12 dB/octave rolloff on either side of the passband and Q control.              |
| ContraBand  | 06    | BPF  | A novel band-pass filter where the frequency peaks and dips midway in the frequency range.            |
| Swept1>1oct | 06    | EQ+  | Parametric filter with 24 dB of boost or cut and a one octave bandwidth.                              |

| Filter Types |                   |
|--------------|-------------------|
| LPF          | Low-pass filter   |
| HPF          | High-pass filter  |
| BPF          | Band-pass filter  |
| EQ+          | EQ boost          |
| EQ-          | EQ cut            |
| VOW          | Vowel / formant   |
| PHA          | Phaser            |
| FLG          | Flanger           |
| REZ          | Special resonance |
| WAH          | Wah-wah           |
| DST          | Distortion        |
| SFX          | Special Effect    |

| Filter Name | Order | Type | Description   |
|-------------|-------|------|---|
| Swept2>1oct | 06    | EQ+  | Parametric filter with 24 dB of boost or cut. The bandwidth of the filter is two octaves wide at the low end of the audio spectrum, gradually changing to one octave wide at the upper end of the spectrum.   |
| Swept3>1oct | 06    | EQ+  | Parametric filter with 24 dB of boost or cut. The bandwidth of the filter is three octaves wide at the low end of the audio spectrum, gradually changing to one octave wide at the upper end of the spectrum. |
| DJAlkaline  | 12    | EQ+  | Band accentuating filter, Q shifts "ring" frequency.  |
| AceOfBass   | 12    | EQ+  | Bass-boost to bass-cut morph  |
| TB-OrNot-TB | 12    | EQ+  | Great Bassline "Processor."   |
| BolandBass  | 12    | EQ+  | Constant bass boost with mid-tone Q control.  |
| BassTracer  | 12    | EQ+  | Low Q boosts bass. Try sawtooth or square waveform with Q set to 115.   |
| RogueHertz  | 12    | EQ+  | Bass with mid-range boost and smooth Q. Sweep cutoff with Q at 127.   |
| RazorBlades | 12    | EQ-  | Cuts a series of frequency bands. Q selects different bands.  |
| RadioCraze  | 12    | EQ-  | Band limited for a cheap radio-like EQ  |
| AahAyEeh    | 06    | VOW  | Vowel formant filter which sweeps from "Ah" sound, through "Ay" sound to "Ee" sound at maximum frequency setting. Q varies the apparent size of the mouth cavity.   |
| Ooh-To-Aah  | 06    | VOW  | Vowel formant filter which sweeps from "Oo" sound, through "Oh" sound to "Ah" sound at maximum frequency setting. Q varies the apparent size of mouth cavity.   |
| MultiQVox   | 12    | VOW  | Multi-Formant, Map Q To velocity.   |
| Ooh-To-Eee  | 12    | VOW  | Oooh to Eeee formant morph.   |
| TalkingHedz | 12    | VOW  | "Oui" morphing filter. Q adds peaks.  |
| Eeh-To-Aah  | 12    | VOW  | "E" to "Ah" formant movement. Q accentuates "peakiness."  |
| UbuOrator   | 12    | VOW  | Aah-Uuh vowel with no Q. Raise Q for throaty vocals.  |
| DeepBouche  | 12    | VOW  | French vowels! "Ou-Est" vowel at low Q.   |
| PhazeShift1 | 06    | PHA  | Recreates a comb filter effect typical of phase shifters. Frequency moves position of notches. Q varies the depth of the notches.   |



**Filter Types**

|            |                   |
|------------|-------------------|
| <b>LPF</b> | Low-pass filter   |
| <b>HPF</b> | High-pass filter  |
| <b>BPF</b> | Band-pass filter  |
| <b>EQ+</b> | EQ boost          |
| <b>EQ-</b> | EQ cut            |
| <b>VOW</b> | Vowel / formant   |
| <b>PHA</b> | Phaser            |
| <b>FLG</b> | Flanger           |
| <b>REZ</b> | Special resonance |
| <b>WAH</b> | Wah-wah           |
| <b>DST</b> | Distortion        |
| <b>SFX</b> | Special Effect    |

| <b>Filter Name</b> | <b>Order</b> | <b>Type</b> | <b>Description</b>  |
|--------------------|--------------|-------------|---|
| PhazeShift2        | 06           | PHA         | Comb filter with slightly different notch frequency moving the spacing of notches. Q varies the depth of the notches. |
| FreakShifta        | 12           | PHA         | Phasey movement. Try major 6 interval and maximum Q.  |
| CruzPusher         | 12           | PHA         | Accentuates harmonics at high Q. Try with a sawtooth LFO.   |
| FlangerLite        | 06           | FLG         | Contains three notches. Frequency moves frequency and spacing of notches. Q increases flanging depth.                 |
| AngelzHairz        | 12           | FLG         | Smooth sweep flanger. Good with vox waves. eg. I094, Q =60  |
| DreamWeava         | 12           | FLG         | Directional Flanger. Poles shift down at low Q and up at high Q.  |
| MeatyGizmo         | 12           | REZ         | Filter inverts at mid-Q.  |
| DeadRinger         | 12           | REZ         | Permanent "Ringy" Q response. Many Q variations.  |
| ZoomPeaks          | 12           | REZ         | High resonance nasal filter.  |
| AcidRavage         | 12           | REZ         | Great analog Q response. Wide tonal range. Try with a sawtooth LFO.   |
| BassOMatic         | 12           | REZ         | Low boost for basslines. Q goes to distortion at the maximum level.   |
| LucifersQ          | 12           | REZ         | Violent mid Q filter! Take care with Q values 40-90.  |
| ToothComb          | 12           | REZ         | Highly resonant harmonic peaks shift in unison. Try mid Q.  |
| EarBender          | 12           | WAH         | Midway between wah & vowel. Strong mid-boost. Nasty at high Q settings.   |
| FuzziFace          | 12           | DST         | Nasty clipped distortion. Q functions as mid-frequency tone control.  |
| BlissBatz          | 06           | SFX         | Bat phaser from the Emulator 4.   |
| KlangKling         | 12           | SFX         | Ringing Flange filter. Q "tunes" the ring frequency.  |

## Vintage Pro Filter Types

### Filter Parameters

The Freq and Q parameters control various elements of the filter depending on the type of filter used. See the table in the *Filter Types* section for details about what the Freq and Q fields control in each filter.

|       |             |    |     |
|-------|-------------|----|-----|
| L1    | FILTER      |    |     |
| Freq: | <u>2</u> 55 | Q: | 019 |

## Filter Envelope

The Filter Envelope is normally used to control the filter frequency and has six stages. Unlike the Volume Envelope, the Filter Envelope must be patched to the Filter Frequency using a PatchCord. In this respect, it can be thought of as a general purpose envelope generator which is normally patched to control the filter. The Filter Envelope Levels can be negative as well as positive.

There are three mode options:

- **Time-based:** Defines the Filter Envelope rates from 0 to 127 (approximately 1 ms to 160 seconds). The Master clock has no affect on time-based rates.

|          |          |            |       |
|----------|----------|------------|-------|
| L1       | FILT ENV | RATE       | LEVEL |
| Attack 1 |          | <u>8</u> 4 | 100%  |

- **Tempo-based:** The Filter Envelope times vary based on the master tempo setting and are displayed in values such as 1, 2, 3, etc. Note values are displayed instead of a number when the time corresponds to an exact note value. Tempo-based envelopes are useful when using arpeggiators and sequencers because the envelope rates compress and expand according to the Master Tempo setting, keeping the envelopes in sync with the music. See the illustration on page 88.

|          |          |             |       |
|----------|----------|-------------|-------|
| L1       | FILT ENV | RATE        | LEVEL |
| Attack 1 |          | <u>1</u> /4 | 100%  |

### Envelope Repeat

The Envelope Generators can also be made to repeat. When the envelope repeat function is On, the Attack (1&2) and Decay (1&2) stages will continue to repeat as long as the key is held. As soon as the key is released, the envelope continues through its normal Release stages (1 & 2). For more information, see “Envelope Repeat” on page 88.

#### ► To Turn on Envelope Repeat:

1. Move the cursor until it is underneath the Mode field as shown below.



2. Turn the data entry control clockwise. The lower line changes to:



3. Move the cursor underneath the on/off field, then turn the data entry control clockwise so that Repeat is On.

 See the Programming Basics section of this manual for detailed information about how the Envelopes work.

 The default PatchCord settings connect the Filter Envelope to Filter Frequency but the envelope can be routed to any real-time control destination using a PatchCord.

### Defining the Filter Envelope

The Filter Envelope controls the filter frequency of the layer over time. The Envelope has six stages to the contour: Attack 1, Attack 2, Decay 1, Decay 2, Release 1 and Release 2. When a key is pressed, the Envelope goes through the first four stages. If the key continues to be held, the envelope holds at the Decay 2 level. When the key is released, the envelope immediately jumps to the Release 1 stage, then the Release 2 stage finally ending at the Release 2 level.

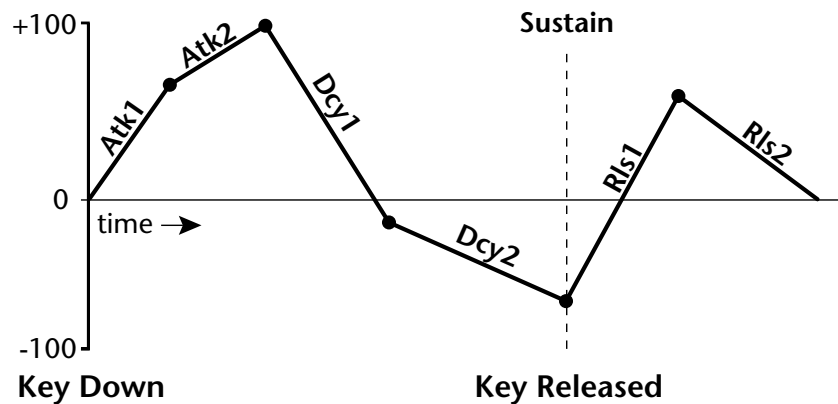

### Auxiliary Envelope

The Auxiliary Envelope is a supplementary general purpose envelope that can be routed to any real-time control destination in the PatchCords. It is identical to the filter envelope generator. See “Filter Envelope” on page 136 for full details.

### Low Frequency Oscillators (LFOs)

A Low Frequency Oscillator or LFO, is simply a wave that repeats at a slow speed. Vintage Pro has two LFOs per layer identified on the display as LFO1 and LFO2.

An LFO can be routed to any real-time control destination using a PatchCord. LFOs have a myriad of uses, some of which probably haven’t been thought of yet. The following examples show a few common uses.

- Control the pitch of the sound (LFO -> Pitch). This effect is called “vibrato” and is an important performance tool. Many presets use this routing with the modulation wheel controlling “how much” modulation is applied.
- Create a “tremolo” effect by routing the LFO to control the volume (LFO -> AmpVolume).
- Add a bit of animation to the sound by routing the LFO to control the filter. Set the PatchCord amount low for a subtle effect.

The LFOs have five parameters: Shape, Sync, Rate, Delay and Variation.

### Shape

LFO waveforms have different shapes. The shape of the waveform determines the effect of the LFO. LFOs have traditionally been used to add vibrato or repeating movement to a sound. These new shapes offer a lot of new programming possibilities.

If you modulate the pitch of an instrument, it's easy to visualize the shape of the waveform. For example, the sine wave has a smooth, rolling shape that changes the pitch smoothly. The square wave changes between two pitches abruptly. A sawtooth waveform increases the pitch smoothly, then abruptly changes back down. The available waveforms are shown below.

#### LFO Tricks & Tips:

- The Random LFO wave is truly random and is different for each voice and layer.
- The Pattern (Pat) waveforms will sound the same on different layers and voices.
- Sine + Noise is very useful for simulating trumpet and flute vibrato.

#### ★ When routing Hemi-quaver to Pitch:

- +38 = major scale
- 38 = phrygian scale
- +76 = whole tone scale
- (+38) + (+76) = diminished (two cords)
- odd amount = S+H sound

**Note:** References to musical intervals in the pattern LFO shapes are with the LFO routed to pitch and a PatchCord amount of +38.

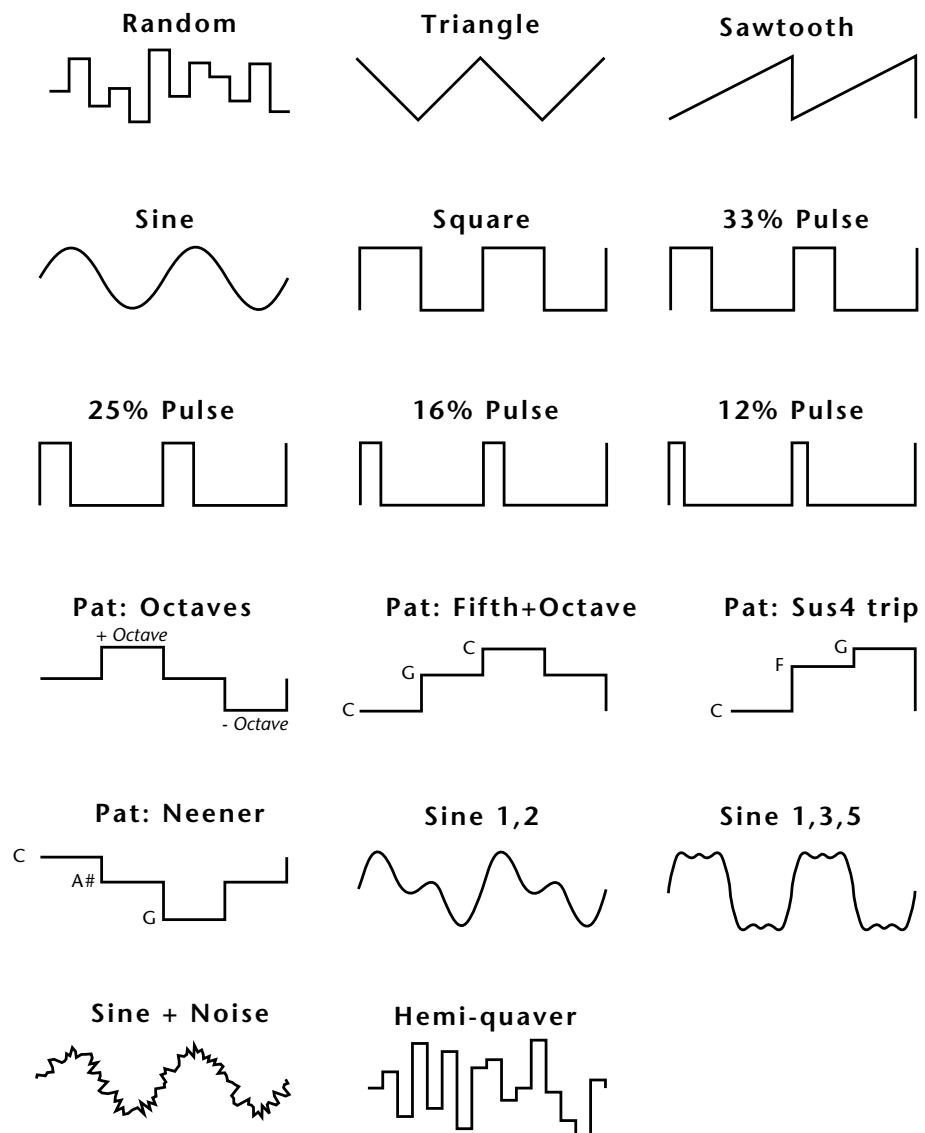

|    |      |          |                 |
|----|------|----------|-----------------|
| L1 | LFO1 | SHAPE    | SYNC            |
|    |      | sawtooth | <u>key</u> sync |



LFO Synced to 1/4 Note Clock

### Sync

The Sync field specifies whether the LFO is synchronized to a key stroke or is Free Running. Key Sync starts the LFO wave at the beginning of its cycle each time you press a key on the controller. In Free Run mode, the LFO wave begins at a random point in its cycle each time you press a key on the controller.

### Rate

The Rate field determines the LFO speed in absolute frequency rate values or tempo-based note values. All values equal to or greater than zero specify absolute frequency values from 0.08 Hz to 18.14 Hz.

Values less than zero specify tempo-based rates. If you modulate the rate of a tempo-based LFO, the rates will jump between the tempo-based note values with each PatchCord increment of "1". As an example: if the LFO rate was set to 8/1 and you patched the Mod Wheel to control rate with a PatchCord amount of +1, turning the Mod Wheel to maximum would change the LFO rate to 4/1d. Refer to the chart below.

|    |      |                |       |     |
|----|------|----------------|-------|-----|
| L1 | LFO1 | RATE           | DELAY | VAR |
|    |      | <u>0</u> .08Hz | 60    | 020 |

| Tempo-based Rates<br>(based on Master Tempo) | Display |
|--|---------|
| octal whole note                             | 8/1     |
| dotted quad whole note                       | 4/1d    |
| octal whole note triplet                     | 8/1t    |
| quad whole note                              | 4/1     |
| dotted double whole note                     | 2/1d    |
| quad whole note triplet                      | 4/1t    |
| double whole note                            | 2/1     |
| dotted whole note                            | 1/1d    |

| <b>Tempo-based Rates<br/>(based on Master Tempo)</b> | <b>Display</b> |
|--|----------------|
| double note triplet                                  | 2/1t           |
| whole note   | 1/1            |
| dotted half note                                     | 1/2d           |
| whole note triplet                                   | 1/1t           |
| half note  | 1/2            |
| dotted quarter note                                  | 1/4d           |
| half note triplet                                    | 1/2t           |
| quarter note   | 1/4            |
| dotted 8th note                                      | 1/8d           |
| quarter note triplet                                 | 1/4t           |
| 8th note   | 1/8            |
| dotted 16th note                                     | 1/16d          |
| 8th note triplet                                     | 1/8t           |
| 16th note  | 1/16           |
| dotted 32nd note                                     | 1/32d          |
| 16th note triplet                                    | 1/16t          |
| 32nd Note  | 1/32           |

### Delay

The Delay parameter defines the amount of time between hitting a key on the controller and the onset of the LFO modulation. Delay can be used to simulate an effect often used by acoustic instrument players where the vibrato is brought in only after the initial note pitch is established. The following illustration demonstrates how delay works.

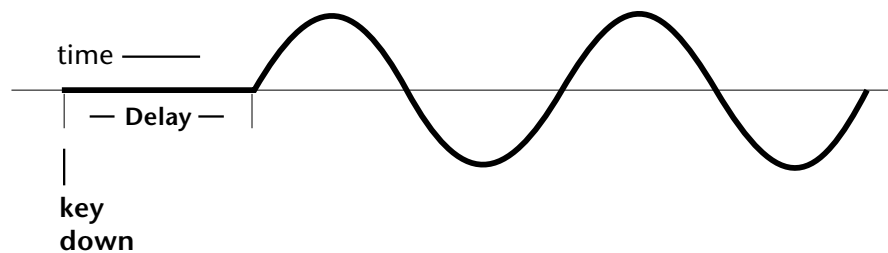

All Delay values equal to or greater than zero specify absolute time rates from 0 to 127. Values less than zero specify Tempo-based mode. Refer to the previous table for times and tempo-based rates.

### Variation

LFO Variation sets the amount of random variation of the LFO each time you press a key on the controller. This creates a chorus or ensemble effect since each note played has a slightly different modulation rate. The higher the value entered, the greater the note to note variation in the LFO.

The Variation value range is from 0 through 100.



*Variation is disabled when a Tempo-Based LFO is selected.*

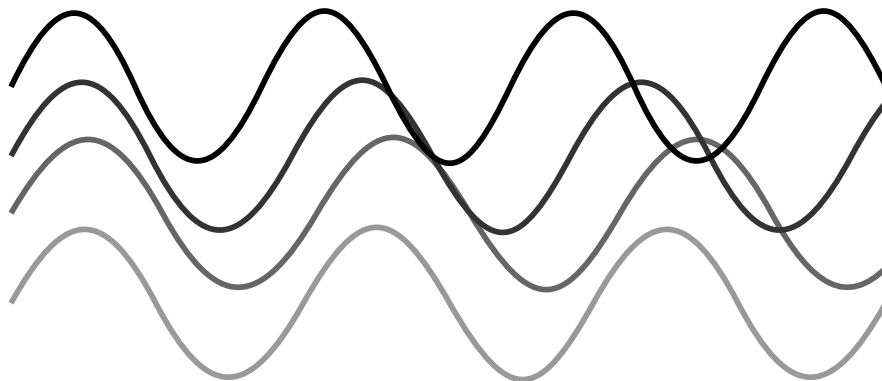

LFO variation changes the rate of each note to create an “ensemble” effect.



## PatchCords

PatchCords tie everything together by connecting modulation sources to destinations. Each PatchCord has its own *Amount* control which can be positive or negative (negative amounts invert the signal). In addition, the PatchCord amounts themselves can be controlled by any modulation source. Vintage Pro provides 24 patches for each layer.

There are three permanently connected control routings: volume envelope to amplifier, pitch wheel to pitch and key to pitch. All other connections must be made using the PatchCords.

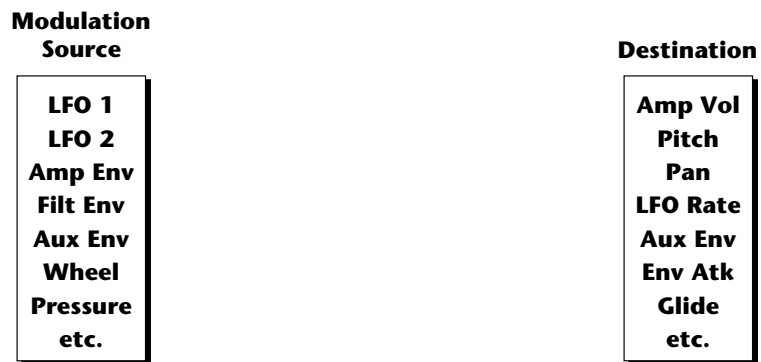
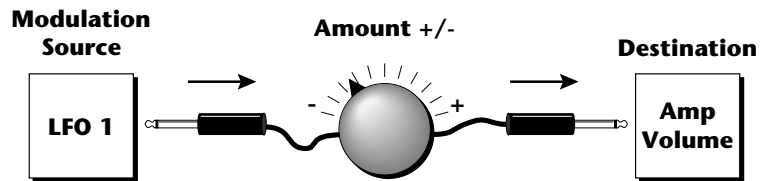

Each patch has an amount field which determines how much modulation is applied to the destination. The modulation amount can be positive or negative. Negative values invert the input. The amount value range is from -100 to +100.

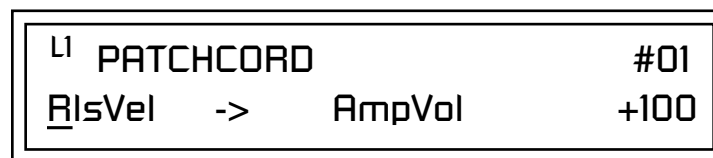

### Modulator Polarity

You will notice that some of the modulation sources have symbols following their names. For example, there are three Velocity modulation sources, Vel +, Vel ±, and Vel <.

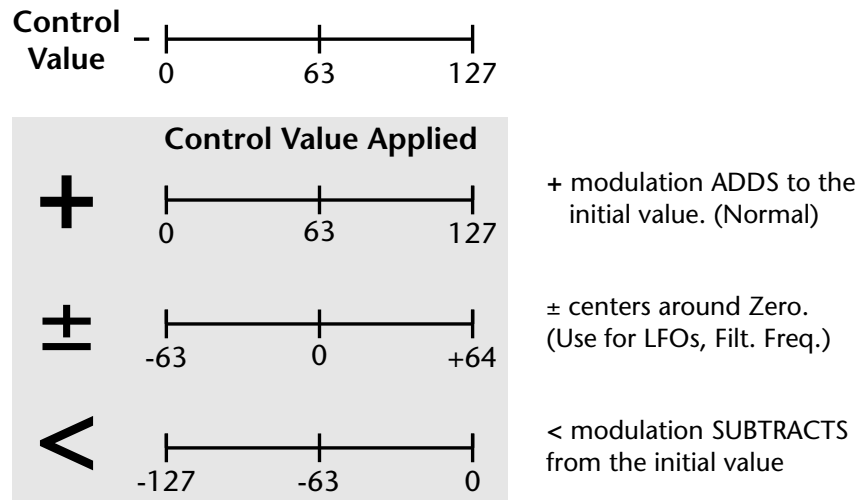

**“+” Modulation:** Uses only the positive half of the range, adding to the current value. For example, if the filter frequency were set to 100 and you patched Vel+ to the filter, the filter frequency would increase from 100 as velocity was applied.

**“±” Modulation:** Uses both sides (full) range and both adding and subtracting from the current value. For example, if the filter frequency were set to 100 and you patched Vel ± to the filter, the filter frequency would decrease from 100 with key velocities of 63 or less and increase from 100 with key velocities of 64 and above. Therefore with medium velocity, the Filter frequency is approximately where you set it at 100.

An LFO ± works the same way; on the positive half of the cycle it increases the initial amount and on the negative half of the cycle it decreases the initial amount. With a ± modulation source, a value of 64 equals 0.

**“<” Modulation:** Uses only the negative half of the range, subtracting from the current value. For example, if the Amplifier Volume were set to +3 dB and you patched Vel < to AmpVol, the volume would be at +3 dB only when maximum key velocity were applied. Lower key velocities would scale back the volume. In general, < modulation is the proper choice when modulating Volume.

Refer to the following table for a list of modulation sources and destinations available in the Vintage Pro.

**Modulation Sources:**

Off  
 Key (+, ±)  
 Velocity (+, ±, <)  
 RlsVel (Release Velocity)  
 Gate  
 Pressure  
 PitchWhl (Pitch Wheel)  
 ModWhl (Modulation Wheel)  
 Pedal  
 MIDI A-L  
 PLagOut (Preset Lag Out)  
 PRampOut (Preset Ramp Out)  
 FootSw1 - 3 (Foot Switch 1-3)  
 FootnFF (Flip-Flop Foot Switch 1 -3)  
 MIDI Volume (Controller 7)  
 MIDI Pan (Controller 10)  
 KeyGlide  
 VolEnv +, ±, < (Volume Envelope)  
 FilEnv +, ±, < (Filter Envelope)  
 AuxEnv +, ±, < (Auxiliary Envelope)  
 LFO 1 & 2 (+, ±)  
 White (White Noise)  
 Pink (Pink Noise)  
 XfdRand (Crossfade Random)  
 KeyRand 1 & 2 (Key Random)  
 Lag 0 sum (summing amp out)  
 Lag 1 sum (summing amp out)  
 Lag 0 & 1 (Lag Processor)  
 Clk Divisors (Octal, Quad, Double  
 Whole, Whole, Half, Qtr, 8th,16th)  
 DC (DC Offset)  
 Summing Amp  
 Sum  
 Switch  
 Absolute Value  
 Diode  
 Flip-Flop  
 Quantizer  
 4x Gain

**Modulation Destinations**

Off  
 KeySust (Key Sustain)  
 FinePtch (Fine Pitch)  
 Pitch  
 Glide  
 ChrsAmt (Chorus Amount)  
 'SStart (Sample Start) -note-on)  
 SLoop (Sample Loop)  
 SRetrig (Sample Retrigger)  
 FiltFreq (Filter Frequency)  
 'FiltRes (Filter Resonance -note-on)  
 AmpVol (Amplifier Volume)  
 AmpPan (Amplifier Pan)  
 RTXfade (Real-time Crossfade)  
 VEnvRts (Volume Envelope Rates -all)  
 VEnvAtk (Volume Envelope Attack)  
 VEnvDcy (Volume Envelope Decay)  
 VEnvRls (Volume Envelope Release)  
 FEnvRts (Filter Envelope Rates -all)  
 FEnvAtk (Filter Envelope Attack)  
 FEnvDcy (Filter Envelope Decay)  
 FEnvRls (Filter Envelope Release)  
 FEnvTrig (Filter Envelope Trigger)  
 AEnvRts (Auxiliary Envelope Rates -all)  
 AEnvAtk (Auxiliary Envelope Attack)  
 AEnvDcy (Auxiliary Envelope Decay)  
 AEnvRls (Auxiliary Envelope Release)  
 AEnvTrig (Auxiliary Envelope Trigger)  
 LFO 1 & 2 Rate  
  
 LFO 1 & 2 Trigger  
 Lag Processor In 0 & 1  
 Sum (Summing Amp)  
 Switch  
 Abs (Absolute Value)  
 Diode  
 Quantize  
 Flip-Flop  
 Gain 4x  
 Cord 1-24 Amount

## Pitch Bend Range

Specifies the Pitch Wheel range in semitones for the current layer. Pitch Wheel is a standard synthesizer control which is transmitted as a MIDI continuous controller message used (normally) to bend the pitch up and down.

The PitchBend range is from 0 to  $\pm 12$  semitones or "Master." A setting of "0" turns the pitch wheel Off for the current layer. The Master setting uses the Pitch Bend range defined in the *Master menu*.

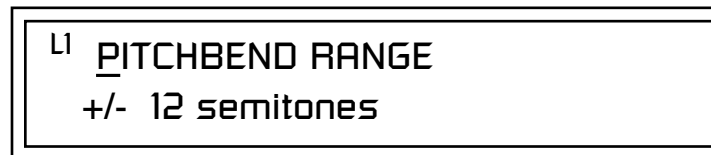

## Mix Output

This feature allows you to program the Effect Send as a part of the preset. Note that for this feature to work, the Mix Output setting in the Master menu MUST be set to "Preset" on the selected MIDI channel. If you want to define output routing by MIDI channel, set it up using the Mix Output page in the Master menu. See "Mix Output" on page 66 for more information.

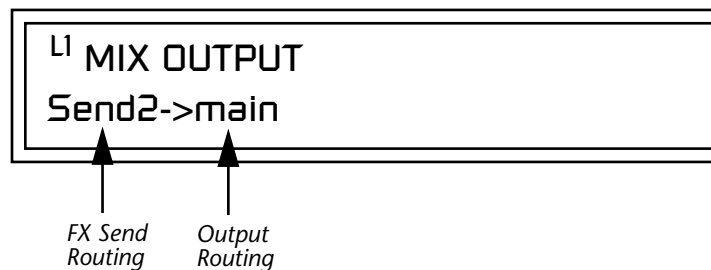

 The entire Send is disconnected from the Effects Processors even if only one plug is inserted into the Submix jack.

The Sends function as effect processor inputs (effect sends). Send 2 and Send 3 are also used to route sounds to the Sub 2 and 3 outputs on the back panel. When a plug is inserted into the associated Submix jack on the back panel, the dry portion of the Send is routed directly to the output jack, bypassing the effects processor.

The Output Routing field shows the true routing of the Sends either to Main (through the effects processor) or directly to a Submix output. If a plug was inserted into a Sub 1 jack, the screen above would change to show, "Send2 -> sub1". This indicates that the preset is routed to the Sub 1 output jacks.

## Common Preset Parameters

### Preset Effects

This section of the Edit menu chapter describes parameters that affect all layers in the preset.

Vintage Pro has two stereo effects processors. When playing presets one at a time, the two processors can be programmed as part of the preset. The diagram below shows how the effects are integrated into the signal path using a parallel effects send/return model, similar to a mixing console.

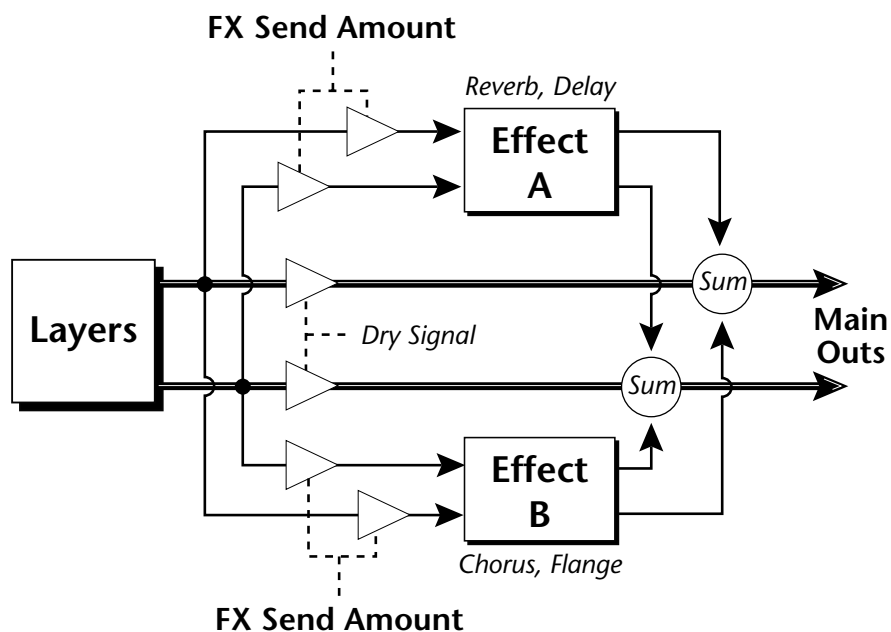

Refer to the Effects chapter for additional information and instructions for setting up both the Preset Effects and the Master Effects.

## OUTPUT SECTION & EFFECTS PROCESSORS

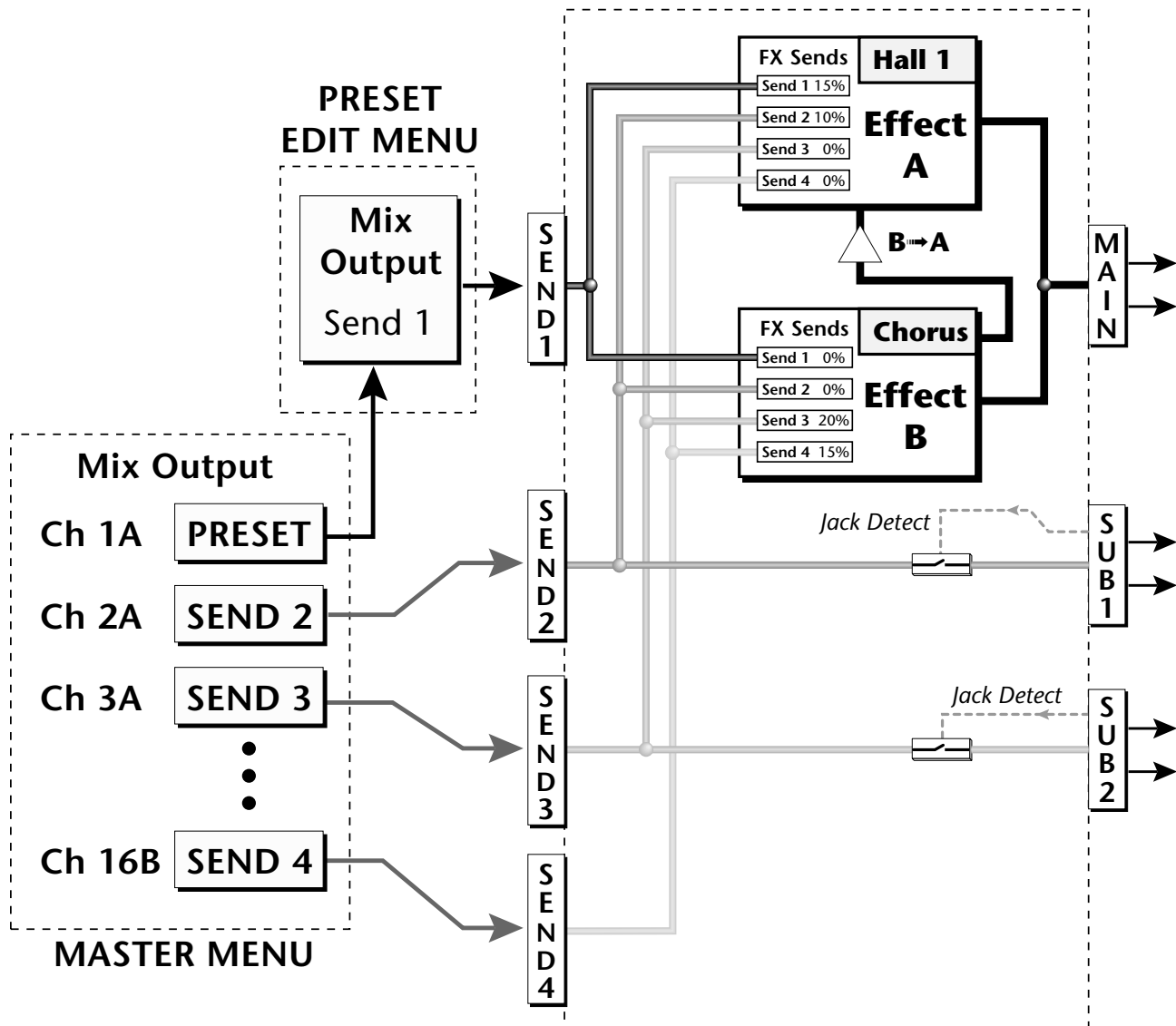

The Mix Output setting in the Master Menu determines if the Preset's Mix Output routing will be used. This allows the Sends to be programmed by either MIDI Channel or by Preset, whichever you prefer.

## FXA Algorithm

This screen selects the effect type for Effect Processor A. The “A” effects consist of different reverb types and digital delays. Move the cursor to the lower line of the display and select the effect you want.

**FXA ALGORITHM**  
**Lg Concert Pan**

### A Effect Types

1. Room 1
2. Room 2
3. Room 3
4. Hall 1
5. Hall 2
6. Plate
7. Delay
8. Panning Delay
9. Multitap 1
10. Multitap Pan
11. 3 Tap
12. 3 Tap Pan
13. Soft Room
14. Warm Room
15. Perfect Room
16. Tiled Room
17. Hard Plate
18. Warm Hall
19. Spacious Hall
20. Bright Hall
21. Bright Hall Pan
22. Bright Plate
23. BBall Court
24. Gymnasium
25. Cavern
26. Concert 9
27. Concert 10 Pan
28. Reverse Gate
29. Gate 2
30. Gate Pan
31. Concert 11
32. Medium Concert
33. Large Concert
34. Large Concert Pan
35. Canyon
36. DelayVerb 1
37. DelayVerb 2
38. DelayVerb 3
39. DelayVerb 4 Pan
40. DelayVerb 5 Pan
41. DelayVerb 6
42. DelayVerb 7
43. DelayVerb 8
44. DelayVerb 9

### FXA Parameters

The FXA parameters are Decay, High Frequency Damping, and the FxB to FxA send. **Decay** sets the length of time it takes an effect to fade out. **HF Damping** causes the high frequency energy to fade away more quickly during the reverb decay. **FxB to FxA** controls the amount of the “B” effect sent through effect “A”. This allows you to place the two effects in series and create setups such as “distortion through reverb” among others. Please refer to the Effects chapter for more information about the effects.

|     |       |        |         |
|-----|-------|--------|---------|
| FXA | DECAY | HFDAMP | FxB>FxA |
|     | 048   | 064    | 000     |

### FXA Send Amounts

These parameters set the effects amounts for each of the four stereo effects busses.

|                  |        |
|------------------|--------|
| FXA SEND AMOUNTS | 1:100% |
| 2: 50%           | 3: 10% |
|                  | 4: 0%  |

### FXB Algorithm

This screen selects the effect type for Effect Processor A. Move the cursor to the lower line of the display and select the effect you want.

|               |
|---------------|
| FXB ALGORITHM |
| Panning Delay |

#### B Effect Types

- |              |                    |                       |
|--------------|--------------------|-----------------------|
| 1. Chorus 1  | 12. Flange 5       | 23. PanDelay Chorus 1 |
| 2. Chorus 2  | 13. Flange 6       | 24. PanDelay Chorus 2 |
| 3. Chorus 3  | 14. Flange 7       | 25. Dual Tap 1/3      |
| 4. Chorus 4  | 15. Big Chorus     | 26. Dual Tap 1/4      |
| 5. Chorus 5  | 16. Symphonic      | 27. Vibrato           |
| 6. Doubling  | 17. Ensemble       | 28. Distortion 1      |
| 7. Slapback  | 18. Delay          | 29. Distortion 2      |
| 8. Flange 1  | 19. Delay Stereo   | 30. Distorted Flange  |
| 9. Flange 2  | 20. Delay Stereo 2 | 31. Distorted Chorus  |
| 10. Flange 3 | 21. Panning Delay  | 32. Distorted Double  |
| 11. Flange 4 | 22. Delay Chorus   |                       |



## FXB Parameters

The FXB parameters are Feedback, LFO Rate and Delay. **Feedback** sends the output of the effect back into the input. This creates multiple echoes on a delay effect and intensifies a chorus or flange effect. **LFO Rate** allows you to change the speed of the modulation oscillator for flange and chorus effects. **Delay** sets the length of the delay line. This affects the time between echoes, or the tone of flange effects.

|     |        |         |       |
|-----|--------|---------|-------|
| FXB | FEEDBK | LFORATE | DELAY |
|     | 032    | 003     | 200ms |

## FXB Send Amounts

These parameters set the effects amounts for the four stereo effects busses.

|                  |        |
|------------------|--------|
| FXB SEND AMOUNTS | 1:100% |
| 2: 50%           | 3: 10% |
|                  | 4: 0%  |

## Preset Patchcords

Preset PatchCords give you real-time control of global parameters. The effect processors are a powerful synthesis tool and this feature lets you control and use them in exciting new ways. There are 12 effects PatchCords per preset with a source, a destination and an amount control. The amount can be set from -100 to +100. The effects PatchCord controls are **added** to the FX Send Amounts set in the Master or Edit menus.



The FX Cords allow you to crossfade between effects.

- 1) Set FXA Send 1 to 100%.
- 2) Set FXB Send 1 to 0%.
- 3) Set FX Cord #1 to FXA Send 1 at -100.
- 4) Set FX Cord #2 to FXB Send 1 at +100.

Increasing the controller amount will crossfade from FXA to FXB.

|              |             |      |
|--------------|-------------|------|
| PRESET CORDS |             | #    |
| Pedal        | -> FXBSend2 | +100 |

### Modulation Sources:

Off  
 PitchWhl (Pitch Wheel)  
**Channel Pressure**  
 ModWhl (Mod Wheel - Controller 1)  
 Pedal (Controller 4)  
 MIDI Volume (Controller 7)  
 MIDI Pan (Controller 10)  
 MIDI A-L  
 Footswitch 1

### Modulation Destinations

Off  
 Effect A Send 1  
 Effect A Send 2  
 Effect A Send 3  
 Effect A Send 4  
 Effect B Send 1  
 Effect B Send 2  
 Effect B Send 3  
 Effect B Send 4

**Modulation Sources:**

Flip-Flop Footswitch 1  
Footswitch 2  
Flip-Flop Footswitch 2  
Footswitch 3  
Flip-Flop Footswitch 3  
DC

**Modulation Destinations**

Preset Lag In  
Preset Lag Amount  
Preset Lag Rate  
Preset Ramp Rate  
Arp Rate  
Arp Extension  
Arp Velocity  
Arp Gate  
Arp Interval  
Beats Velocity, Group 1-4  
Beats Transpose (Xps) Group 1-4  
Beats Busy  
Beats Variation

### Initial Controller Amount

This parameter sets the initial value of MIDI controllers A-L when the preset is first selected. The front panel Control Knobs can be thought of as front panel MIDI controllers because in the Vintage Pro, they are treated just as if they originated from an external MIDI device. Refer to the following diagram. There are three Initial Controller Amount screens (A-D, E-H, I-L).

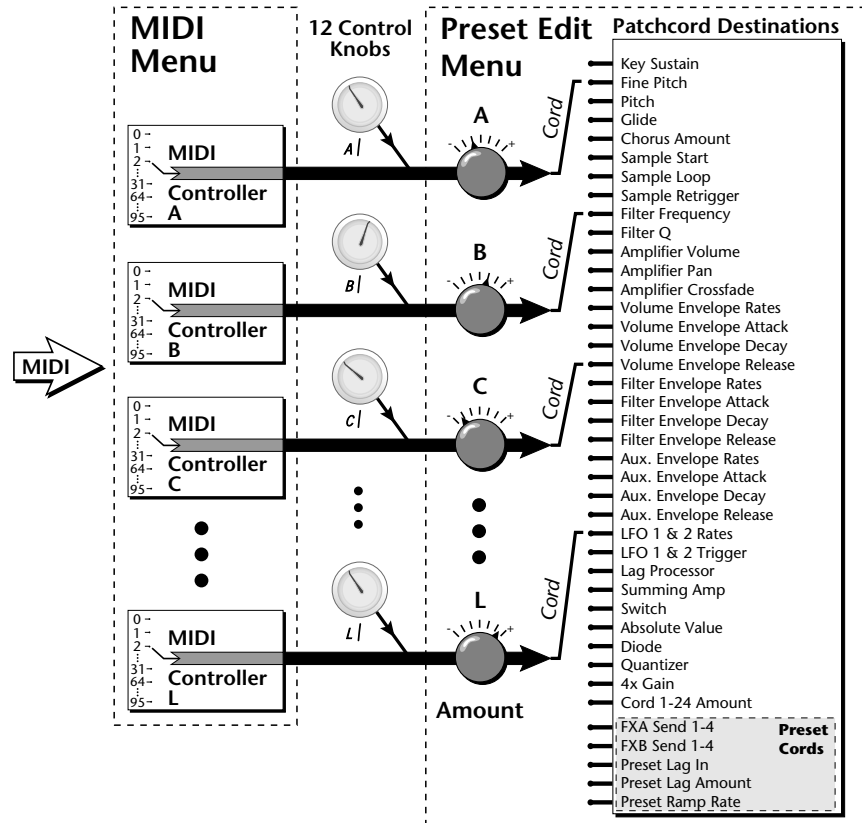

External MIDI controller numbers are assigned to the Letters A-L in the Master menu. The Initial Controller Amount value is sent to the PatchCord destination when the Preset is first selected. If you move the Control Knob, then that value replaces the initial value. If MIDI controller data is received it will similarly replace the knob or initial setting.

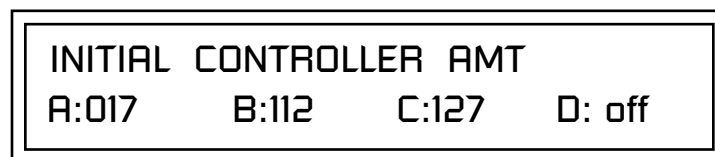

The Initial controller amounts can be set from 000-127 or they can be turned Off. If set to Off, the current controller value is used when the preset is first selected. Setting the Initial Amount to "off" uses the values from the previously selected preset.

## Keyboard Tuning

In addition to the standard equally divided octave tuning, Vintage Pro contains twelve factory programmed tunings and 12 user-definable tunings. The Keyboard Tuning parameter selects which tuning is used by the current preset. The User Tuning tables are defined in the Master menu.

The factory Keyboard Tuning tables are described in the following table.

| <b>Tuning Tables</b>     | <b>Description</b>  |
|--------------------------|---|
| <b>Equal Temperament</b> | Standard Western tuning (12 equally spaced notes per octave)  |
| <b>Just C</b>            | Just intonation. (Based on small interval ratios. Sweet and pure, non-beating intervals.)   |
| <b>Vallotti</b>          | Valotti & Young non-equal temperament. (Similar to 12 tone equal temperament. Each key has a different character for a given scale.)              |
| <b>19-Tone</b>           | 19 tone equal temperament. (19 notes per octave. Difficult to play, but works well with a sequencer.)   |
| <b>Gamelan</b>           | 5 tone Slendro and 7 tone Pelog. (Javanese. Pelog are white keys, Slendro are black keys. Exotic tunings of Gamelan flavor.)                      |
| <b>Just C2</b>           | Allows you to play the following chords in the key of C: C, E, F, G, A, B, C#m, D#m, Em, F#m, G#m, Am, Bm   |
| <b>Just C-minor</b>      | Allows you to play the following chords in the key of C: C, E, F, G, A, B, Em, Am, Bm, C#m, D#m, G#m  |
| <b>Just C3</b>           | Allows you to play the following chords in the key of C: C, D, F, Bb, C#m, Dm, Em, F#m, G#m, Am   |
| <b>Werkmeister III</b>   | A "well" temperament developed in the 17th century. Although you can play in all keys, each key sounds slightly different.                        |
| <b>Kirnberger</b>        | Another well temperament developed by Johann Philipp Kirnberger where no pitch is more than 12 cents off from equal temperament.                  |
| <b>Scarlatti</b>         | A variant of Meantone tuning which was used from the 15th to 18th centuries.  |
| <b>Repeating Octave</b>  | Middle C octave is repeated up and down the keyboard. Link with a preset in equal temperament to form unusual inversion up and down the keyboard. |
| <b>User 1-12</b>         | Define your own tuning tables ( <i>Master menu</i> ).   |

Refer to "User Key Tuning" on page 81 in the Master Menu chapter for instructions on how to define your own Keyboard Tunings.

 Vintage Pro implements the MIDI Tuning Dump protocol which allows you to create tuning tables on your personal computer and download them via MIDI. There are several computer applications available on the internet which let you create and download alternate tuning tables via MIDI.

### The Just C Tuning Tables

Well Tempered and Just were standard keyboard tunings up until the 20th-century when the current “equal tempered” scale became prevalent. In an equal tempered scale, the octave is equally divided into 12 parts. In Just or Well Tempered scales, the 12 notes are separately tuned to produce pure chords. However, in Just tunings you are limited to playing certain chords and if you play the wrong chord it may sound very BAD!

Vintage Pro allows you to modulate between keys by providing you 12 user tuning tables. Tuning tables can be changed as you play using a program change (create several presets with the same sound and different tuning tables), by MIDI SysEx command (using a programmable MIDI footswitch or other device), or using a continuous controller (link 2 presets and crossfade between them using a controller). The Just C2, Just C min, Just C3 Tuning Tables

These new tuning tables take the concept of just intonation a step beyond previous E-MU products. Fully explaining the mysteries of just intonation is beyond the scope of this manual, but the subject is covered exhaustively in Hermann Helmholtz's On the Sensations of Tone, available at most libraries and bookstores.

The new tables are called Just C2, Just C3, and Just C Minor. Try playing in the key of C/Cm using each table. You'll quickly discover both the wonders and the frustrations of just intonation! In Just C, for example, you'll find that the chords C, Em, F, G, and Am sound beautiful. If you hold one of these chords, you'll hear no “beating”. After playing for a few minutes, switch back to Equal Temperament for a rude awakening!

At this point you might wonder why anyone would use Equal Temperament to begin with. For the answer to that question, play a D, Dmi, or Bb chord!. The intervallic ratios that make the C & G chords sound so pure make the D chord sound horribly out of tune. That's why we had to include Just C3. In this tuning, D, Dmi and Bb sound in tune, but the G chord will sound wrong.

Each of the 4 tables allows you to play a different group of common chords in just intonation. Sadly, there is no single 12 note tuning that will allow all of the common chords to be in tune, and of course that's why they invented the equal temperament tuning system that we use today.

#### Just C

Play these chords: C, E, F, G, A, Cm, C#m, Em, F#m, Gm, Am

#### Just C2

Play these chords: C, E, F, G, A, B, C#m, D#m, Em, G#m, Am, Bm

#### Just C2 minor

Play these chords: C, D<sup>b</sup>, D, E<sup>b</sup>, G, A<sup>b</sup>, Cm, Em, Fm, Gm

#### Just C3

Play these chords: C, D, F, B<sup>b</sup>, C#m, Dm, Em, F#m, G#m, Am

## Preset Links

You can link presets to other presets to create layering or keyboard splits. The current preset can be linked with up to two other presets (Links 1 & 2). Each linked preset can be assigned to a specific range in order to create keyboard splits or can be assigned a velocity range to switch links according to key velocity. In addition, you can specify Volume, Pan, Transpose and Delay settings for each Link. The modulation parameters specified in each preset remain in effect for each preset in the link.

|                              |      |
|------------------------------|------|
| LINK 1 Preset                | VROM |
| 000 <sup>2</sup> Preset Name |      |

|        |     |         |
|--------|-----|---------|
| LINK 1 | KEY | VEL     |
| RANGE  | C-2 | G8      |
|        |     | 000-127 |

|        |        |     |
|--------|--------|-----|
| LINK 1 | VOLUME | PAN |
|        | +0dB   | 00  |

|        |           |       |
|--------|-----------|-------|
| LINK 1 | TRANSCOPE | DELAY |
|        | +00       | 0     |

Links provide an easy way to create new sounds by combining the existing presets. Or, you can create your own custom stacked presets with up to 12 layers! We're talking LARGE sounds here. Of course Links can also be used when you just want to stack up two sounds.

As an example, let's stack two presets to create a big sound. Start with a preset you like, then go into the Links screen and start scrolling through the preset list while you play to hear both presets together. When you find a winner, simply Save the preset and you're finished!

- You can "Split" the keyboard up to 12 ways by using combinations of the Layers and Links.
- By adjusting the Velocity for the link, you can bring in the link by playing hard.
- Transposing the Link can radically change the sound.
- The delay parameter lets you create surprise effects, echoes or cascades of sound as you continue to hold the keys.

### *Preset Tempo Offset*

This function allows you to double or halve the Master Tempo as it applies to this preset. When playing or sequencing several presets in Multimode, the Master Tempo may be too fast or slow for one preset. Using this feature, you can adjust the tempo for the misbehaving preset. The Tempo Offset can use the **current tempo** or be set to **half** or **twice** the current tempo.

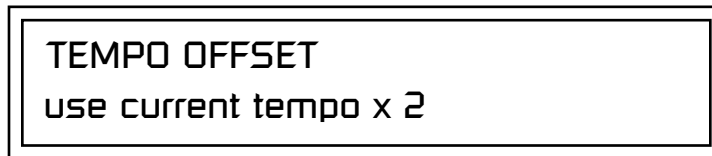

### *Audition Riff Selection*

This function allows you to assign a Riff to a Preset to be played when the front panel Audition button is pressed. A Riff is a short pre-recorded musical phrase designed to demonstrate the presets. A Riff can also be a single note. The Riffs themselves cannot be modified.

Listening to the Riffs is a quick way to learn the sounds in Vintage Pro. Riffs allow the Sound Designers to demonstrate what they had in mind when they designed the preset. If a preset has hidden tricks or controllers, these will be shown off in the Riff.

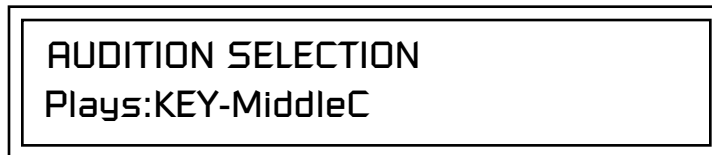

### *Play Solo Layers*

When constructing multilayer sounds it is often useful to turn off one or more of the layers so you can hear what you're doing! This feature allows you to temporarily solo individual layers or listen to them in any combination. This screen differs from the other Edit screens in that it is NOT saved with the preset. The values reset each time you exit the Edit menu.

Solo is activated by setting any layer to On (On = the layer is being Soloed). Any layers set to **On will play** and any layers set to **Off will be muted**. If all layers are set to Off, then Solo mode ends and all layers play normally. When you exit the Edit menu, all layers play normally.

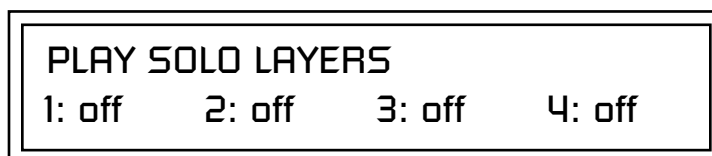





# Programming Tutorial

## Editing Presets

### Changing the Instrument

There is so much you can do with the Vintage Pro it's impossible to describe it all. This chapter will give you some ideas for programming your own custom sounds and contains step-by-step instructions to help you get started. In order to get the most from this chapter, we recommend you actually try each example. Have fun!

One of the easiest ways to make a new preset is to edit an existing preset. This is also an excellent way of becoming familiar with Vintage Pro. If you don't like what you hear, simply select a new preset, then Vintage Pro reverts to the original sound. Changes are not permanent until you Save them (see "Saving a Preset" on page 187).

Let's experiment and modify a few parameters of an existing preset. We'll start with functions that have an obvious effect on the sound: Instrument Select, Tuning, and Chorus.

Changing the instrument is the easiest and most dramatic way to modify an existing preset.

#### ► To Change the Instrument for the Current Layer

1. Choose any cool preset, then press the Edit button.
2. Scroll through the Edit menu until you come to the Instrument page.



3. Move the cursor down to the bottom line (using a Cursor button).
4. Use the Data Entry Control to change the instrument. This changes the instrument for the current layer (in this case it's L1).
5. Play the keyboard as you scroll through the various instruments.

► **To Change the Instrument for any Layer in the Preset**

6. Move the cursor back up to the first field in the first line (the layer).
7. Use the Data Entry Control to select the layer you want.

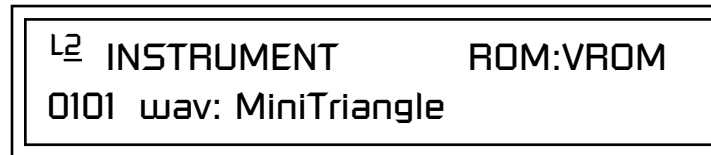

8. Repeat steps 3 and 4 for each selected layer. Find an instrument that sounds good when combined with the previous instruments selected.

With all these great instruments to work with, you really can't go wrong. Now let's play with the tuning.

*Changing the Tuning  
of an Instrument*

Tuning the selected layer of the preset changes the pitch of the key on the controller. If the numbers are "00," it means that the instruments are tuned to concert pitch (A=440 Hz). The Coarse tuning value represents whole semitone intervals. The Fine tuning value shifts the pitch in 1/64 semitones (or 1.56 cents).

► **To Tune the Instrument of the Current Layer**

1. Scroll through the Edit menu until you come to the Tuning page.

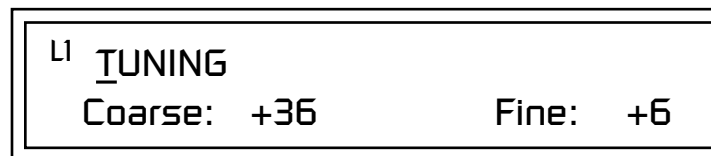

2. Move the cursor to the Coarse field (using the cursor button).
3. Set the value to +12 to shift the pitch up a whole octave. To shift the pitch in smaller units than a semitone, use the Fine field.

Try tuning one of the instruments to a perfect fifth above the other by setting the Coarse value to +7.

Tuning an instrument far out of its normal range completely changes the character of the sound. For example, if you tune a bass guitar up 2 octaves, it's going to sound rather petite. On the other hand, if you tune it down 2 octaves, you can probably rattle plaster off the walls! Experiment with radical pitch shifting. You'll be surprised at the results.

## Chorus



**WARNING:** Since it works by doubling the instruments, Chorus halves the number of notes you can play on Vintage Pro.

This is an easy one. Chorus works by doubling the instruments and detuning them slightly. The larger the chorus value, the more detuning occurs. The Width parameter controls the stereo spread. A Width value of 0% reduces the chorus to mono, a value of 100% provides the most stereo separation. Chorus is useful when you want to “fatten up” a part quickly and easily.

### ► To Chorus a Layer

1. With the cursor on the top line of the display, turn the Data Entry Control until you find the Chorus page.
2. Use the cursor buttons to advance the cursor to the Chorus field (the first field in the bottom line of the display). Use the Data Entry Control to turn on chorus.

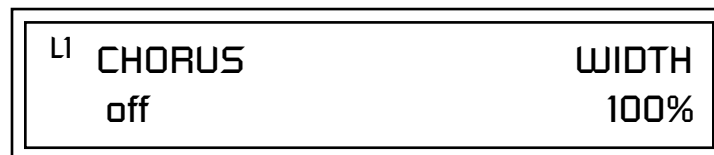

3. Select a Width value based on the amount of detuning you want. Smaller numbers mean less detuning, larger ones more.

You can select various amounts of chorusing for each of the instruments, just play around with the Chorus and Width parameter until you like what you hear.

## Volume Envelope

Every sound you hear, whether it’s a piano note, a drum, or a bell, has a characteristic volume curve or envelope. This Volume Envelope shapes the volume of the sound which grows louder or softer in various ways during the course of the sound. The volume envelope of a sound is one of the clues our brain uses to determine what type of sound is being produced.

An envelope shapes the sound or volume of the sound over time. The envelope generators in Vintage Pro all have six stages to the contour: Attack 1, Attack 2, Decay 1, Decay 2, Release 1 and Release 2. When you press a key on the keyboard, the envelope goes through each of the first four stages, advancing to the next stage when the defined Level for each is reached. As long as you continue to hold the key down, the envelope continues through the first four stages holding at the end of the Decay 2 level until the key is released. When you release the key, the envelope jumps to the Release stages (no matter where the envelope is when you release the key) ending at the Release 2 level.

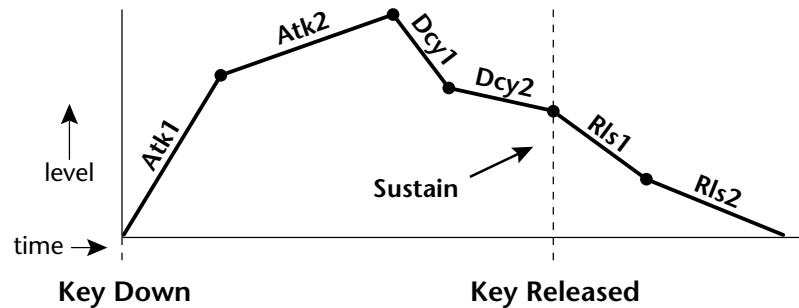
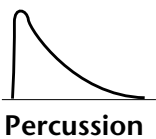
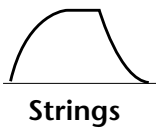
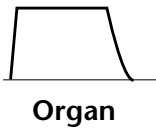
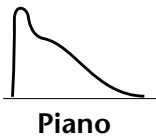

Every instrument in Vintage Pro has its own predetermined volume envelope which is used when the Volume Envelope parameter is set to "factory." By setting the Volume Envelope to "time-based" or "tempo-based," we can reshape the instrument's natural volume envelope any way we want. By reshaping the volume envelope of an instrument, you can dramatically change the way the sound is perceived. For example, you can make "bowed" pianos or backward gongs. The diagrams to the left show the characteristic volume envelopes of a few common sounds.

In preparation for this experiment choose a fairly "normal" preset (like an organ or synth) which continues to sustain when the key is held down. Go to the Instrument page and set it to "None" on all layers except Layer 1. Now you're ready to play with the Volume Envelope.

► **To Setup the Volume Envelope**

1. Go to the Volume Envelope mode screen and set the Volume Envelope mode to "time-based."

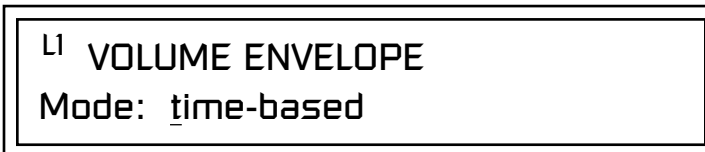

2. Now move on to the next screen to set the Volume Envelope parameters.

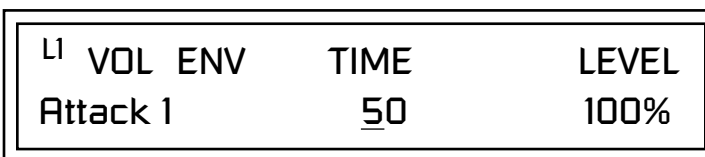

3. Increase the Attack 1 time value and play a note. The attack controls the time it takes for the sound to reach the Attack level when a key is pressed and held.

## Working with Filters

4. Move the cursor to the first field in the bottom line and use the cursor buttons to advance to the Release pages.
5. Increase the Release 1 and 2 times. Note the effect as you release the key on the controller. The Release stages controls the time it takes for the sound to die away when a note is released.

The filters make it possible to remove certain components of the sound. A low pass filter removes the high frequency components or put another way, it “lets the low frequencies pass.” A high-pass filter removes the low frequency components from the sound letting only the high frequencies pass. See “Vintage Pro Filter Types” on page 136 for a complete list of Vintage Pro’s filters and their descriptions.

In preparation for the next tutorial, select preset the “Blank” or “Default” Preset.

1. Go to the Instrument screen and select Instrument #038 - SEM Fuzz. This is a really buzzy sound. Since filters work by removing or accentuating certain frequencies, we want to make sure that we have a lot of frequencies to start with.
1. Advance to the Filter Type screen using the Data Entry Control. Select the VCF Classic filter.

|             |     |      |
|-------------|-----|------|
| L1 FILTER   | Ord | Type |
| VCF Classic | 4   | LPF  |

2. Go to the Filter Frequency and Q screen. Position the cursor in the Freq: field as shown in the following illustration.

|           |        |  |
|-----------|--------|--|
| L1 FILTER |        |  |
| Freq: 255 | Q: 000 |  |

The Frequency parameter determines the filter cutoff frequency or the frequency the filter uses as the highest frequency allowed to pass.

If you play the keyboard now, you should hear the raw Looped Perc 1 sound. Slowly decrease the filter cutoff frequency value as you play the keyboard. The sound gets more and more dull as you remove more and more high frequencies from the sound. At some point, the sound completely disappears. (You have filtered out everything.) The chart on the following page illustrates what you just did.

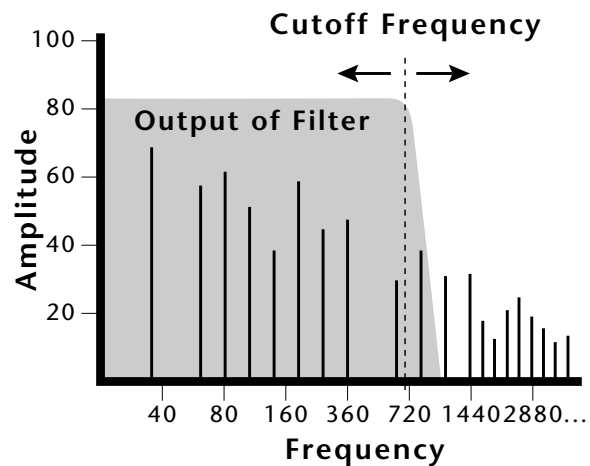

3. Open the filter back up to 255, then move the cursor to the Q field.
4. Set the Q to 10, then move the cursor back under the Freq value. As you change the frequency, notice that the sound now has a sharp, nasal quality. A high Q boosts or amplifies the frequencies at the cutoff frequency (Fc).
5. Reset the cutoff frequency to the lowest setting (0.08Hz) and the Q to 00.

### Adding the Filter Envelope

Now let's modulate the Filter Frequency with the Filter Envelope. The Filter Envelope is a device that can automatically change the filter frequency during the course of the note. Before we define the Filter Envelope, we need to patch the Filter Envelope to the Filter Frequency.

#### ► To Setup the Filter Envelope

1. Go to the PatchCord screen.

|        |           |      |
|--------|-----------|------|
| L1     | PATCHCORD | #01  |
| R1sVel | -> AmpVol | +100 |

2. Move the cursor below the first field in the bottom line of the display. This is the Source field. Use the Data Entry Control to change the Source to "FiltEnv" as shown in the following illustration.
3. Advance the cursor to the next field. This is the Destination field. Use the Data Entry Control to change the destination to "FiltFreq."

4. Move the cursor to the last field in the line. This is the Amount field. The Amount field determines the amount of modulation applied. Set this value to "+100."

|    |                     |          |      |
|----|---------------------|----------|------|
| L1 | PATCHCORD           |          | #01  |
|    | <u>F</u> iltEnv+ -> | FiltFreq | +100 |

This setup connects the Filter Envelope Generator to the Filter Cutoff as shown in the following diagram.

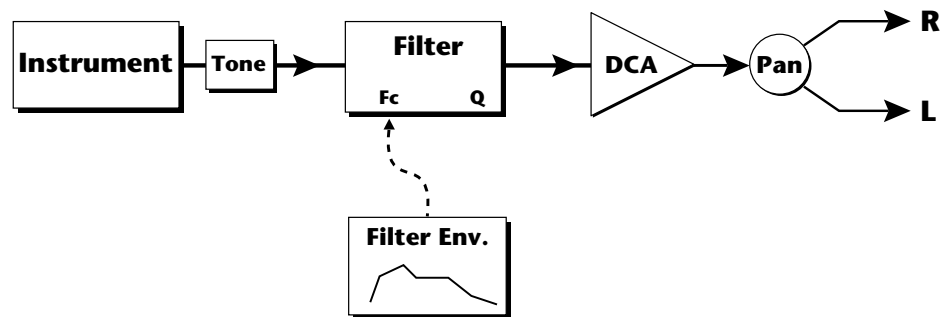

5. Now, return to the Filter Envelope Mode screen. Set the Mode to "time-based."

|    |                          |
|----|--------------------------|
| L1 | FILTER ENVELOPE          |
|    | <u>M</u> ode: time-based |

6. Advance to the Filter Envelope parameter page.

|    |                 |      |              |
|----|-----------------|------|--------------|
| L1 | FILT ENV        | RATE | LEVEL        |
|    | <u>A</u> ttack1 | 50   | <u>1</u> 00% |

7. Move the cursor underneath the time field and change the value to about +50. Now when you press a key the filter slowly sweeps up.

|             |      |       |
|-------------|------|-------|
| L1 FILT ENV | RATE | LEVEL |
| Attack1     | 50   | +88%  |

8. Change the attack rate and note the change in the sound.
9. Set the envelope parameters as shown in the following table.

| Envelope Phase | Time | Level % |
|----------------|------|---------|
| Attack 1       | 40   | 65      |
| Attack 2       | 65   | 100     |
| Decay 1        | 80   | 85      |
| Decay 2        | 25   | 50      |
| Release 1      | 97   | 20      |
| Release 2      | 73   | 0       |

With the above setup, the filter sweeps up, then Decays back down to the Decay 2 Level until you release the key. Then it sweeps down at the Release rates. Play with the envelope parameters for awhile to get a feel for their function. (If you're having trouble understanding the Envelope Generators, please refer to the Programming Basics section in this manual.)

### Changing Filter Types

Go back to the Filter Type screen shown below and move the cursor down the lower line of the display. Change the filter type while playing the keyboard. There are 50 different filter types!

|            |     |      |
|------------|-----|------|
| L1 FILTER  | Ord | Type |
| Aah-Ay-Eeh | 6   | VOW  |

These filters are extremely powerful and have been carefully crafted to offer maximum flexibility and musical control. You may want to change the Envelope (PatchCord) Amount, Q and/or the Filter Frequency to get the right sound for each filter and instrument. These three controls, coupled with the Filter Envelope, are perhaps the most important controls on Vintage Pro. Take the time to learn how they interact with each other and you'll become a synth programming wizard!



## Envelope Repeat

The Envelope Generator can also be made to repeat. When the envelope repeat function is On, the Attack (1&2) and Decay (1&2) stages will continue to repeat as long as the key is held.

### ► To Make the Filter Envelope Repeat:

1. Go to the Filter Envelope **Mode** screen shown below.
2. Move the cursor to the Mode field.



3. Turn the data entry control clockwise. The Mode field will change to Repeat as shown below.



4. Move the cursor to the on/off field and turn Envelope Repeat On.
5. Play a key on the keyboard. You should now hear the envelope repeating.
6. Go back to the envelope parameter page and adjust the Attack 1&2, and Decay 1&2 parameters. The repeating envelope cycles through these four stages as long as the key is held.

## Practice Modulating

- Try modulating the pitch with the Filter Envelope generator
- Use Velocity to modulate the Filter Envelope PatchCord or the Filter Frequency. This brightens the sound as you play harder.
- Program the LFO to modulate Filter Frequency and Volume (Patch-Cord screen).
- Modulate the LFO with the other LFO, with Velocity, and with the Modulation Wheel.
- Think of ten different modulation routings, then try them out. The key to learning how to use Vintage Pro (or any other synth for that matter) is to *experiment*.

## Troubleshooting

A common source of confusion when working with the filter envelope is that the Attack or Release parameters might not seem to be working correctly. If you are not getting the expected result, try to analyze the situation. There will be many times when you will have to stop for a minute and think, "What am I trying to do and why isn't it working?" When this happens (and it will), don't panic. Troubleshooting is a normal part of the synthesis process. Simply examine the various parameters and try to be as analytical as possible as you solve the problem. The solution is usually simple (the filter is already wide open and can't open any more). Learning to play any instrument takes a little patience and practice.

Referring to the diagram below which shows the Vintage Pro signal flow, notice that the DCA comes after the Filter. The DCA controls the final volume of the sound, so if the filter's release is longer than the release for the DCA, you won't hear it, because the DCA has already shut off the sound.

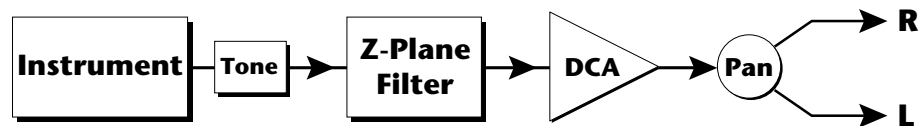

You're getting the general idea by now. Remember not to select a new preset before saving the current one or all your changes will be lost (the preset reverts to the last saved version). If you want to save your creation, select the Save/Copy menu and select a destination preset location for your masterpiece, then press Enter.

Because you can save your work, it's worth spending time to get the sound just right. When designing sounds you become an instrument builder as well as a musician and with Vintage Pro you can design virtually any instrument you want!

## Linking Presets

 See "Preset Links" on page 156 for more information.

Using the Link pages in the Edit menu is a quick and easy way to create new sounds. Use the Links to "layer" presets and to "split" a keyboard into sections containing different sounds.

### ► To Layer Two Presets

1. Select the first preset you want to layer.
2. Press the Edit button. Use the Data Entry Control to move through the screens until you find either the "LINK 1" or "LINK 2" screen shown below.

|        |        |      |
|--------|--------|------|
| LINK 1 | PRESET | VROM |
| off    |        |      |

3. Move the cursor to the second line of the display. Select the preset you want to link with the preset you selected in step 1. Play the keyboard as you scroll through the various presets to hear the results.
4. If you want the link to be a permanent part of the preset, be sure to save the preset. Otherwise, simply change the preset to erase your work.

### ► To Create a Split Keyboard Using Links

1. Follow steps 1 through 4 above.
2. Press Enter and use the Data Entry Control to advance to the next page.

|        |        |         |
|--------|--------|---------|
| LINK 1 | KEY    | VEL     |
| RANGE  | C-2 B4 | 000 127 |

3. Set the keyboard range of the linked preset as desired.
4. Press Enter and use the Data Entry Control to go to the Key Range page (It's one of the first Edit menu pages).

|    |        |      |      |      |
|----|--------|------|------|------|
| L1 | KEY:LO | FADE | HIGH | FADE |
|    | C5     | 000  | G8   | 000  |

5. Set the range of the original preset so it fills the remaining keyboard area. Save the preset.

## Using External Processing

Don't be afraid to use external processing on specific sounds. The submix sends and returns on Vintage Pro are there for just that reason. In many instances, a bit of reverb or EQ will be just the thing an instrument needs to give it a distinct identity. Incidentally, an external fuzz box can work wonders on otherwise harmless sounds. By dedicating one of your old fuzz boxes to a submix out/in, you can have programmable distortion for use on basses, organs, whatever!

Try running a submix out into a guitar amp (*Reduce the volume*). If you think about it, this makes perfect sense if you're looking for an authentic electric guitar or bass sound. You'll be amazed!

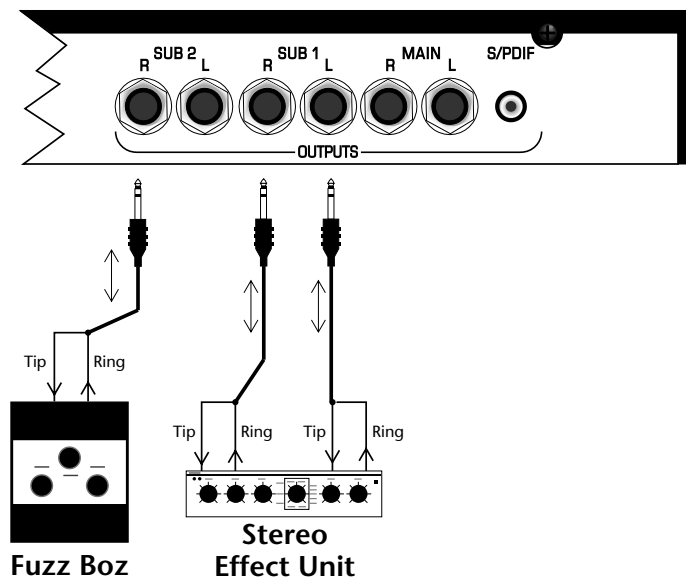

Using the submix outputs and returns, specific presets can be routed through your favorite effects without using up precious mixer channels.\

## Multitimbral Sequencing

“Multitimbral” means that Vintage Pro can play multiple sounds at the same time. For a multitimbral sequence to play back correctly, the proper preset must be selected for each MIDI channel. This could be done by inserting preset changes into each track of your sequence before the sequence starts. Vintage Pro also provides another way to store this “pre-sequence setup” using the Multisetup menu.

Using Multisetups, you’ll set up the preset, volume and pan settings for each MIDI channel as you build your sequence, then save the Multisetup when it’s the way you want it. Sending one preset change command before the sequence starts selects the Multisetup and MIDI settings for all 32 channels.

### ► To Set up Vintage Pro for Multitimbral Operation

1. Set the MIDI mode to “multi mode,” using the MIDI mode function in the Master menu.
2. Decide which MIDI channels you want Vintage Pro to receive (32 channels can be used simultaneously). If you are using 16 MIDI channels or less, just use one of the MIDI ports. Use both MIDI ports if you need more than 16 MIDI channels. You can turn any unused channels OFF using the MIDI Enable function in the Master menu.
3. Select the desired preset for each of the MIDI channels you want the Vintage Pro to receive using the MIDI Channel/Preset selection screen. You can also set the initial Volume and Pan settings for each channel.

1. Select Channel

C01      Vol127      Pan00<sub>R</sub>      User

2. Select Preset

0321<sup>2</sup>      pad: Fem Strings

4. Vintage Pro now responds multitimbrally on each of the MIDI channels you have specified. The volume and pan position parameters can be adjusted dynamically over MIDI (during the sequence).
5. Save the Multisetup.

### ► To Link a Multisetup with your Sequence

1. Insert a MIDI bank and program change in the lead-in measure of your sequence to select the proper Multisetup before the sequence starts.
2. The Multisetup will now be selected before the sequence starts.



# Effects

## Effects Overview

Vintage Pro has two stereo effects processors. When playing presets one at a time, the two processors can be programmed as part of the preset. When the MIDI Mode is set to “multi,” Vintage Pro uses a global effects assignment (Master Effects). The diagram below shows how the effects are integrated into the signal path using a parallel effects send/return model, similar to a mixing console.

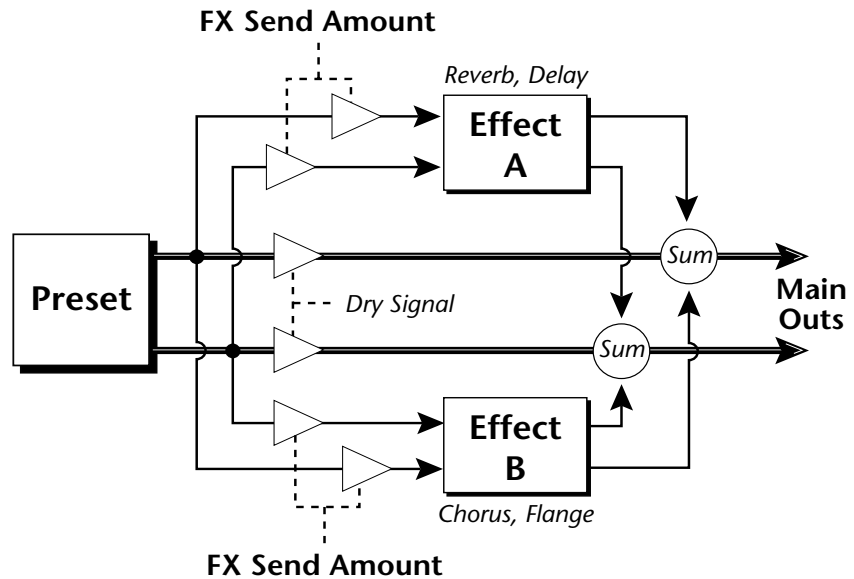

### The Effects Sends

On a mixing console you can control the amount of signal each channel sends to the effect bus. This allows each channel to be placed in a slightly different “sonic space” which creates an airy, open sound.

Vintage Pro uses this basic concept, but works in a slightly different manner. There are four effects busses: Send1-Send4. Each preset or each MIDI channel (you determine which), can be directed to one of the four busses. Each effect processor has four Send Amounts which allow you to set the wet/dry mix on each of the four busses going into the effect. A setting of 0% is completely dry (no effect). A setting of 50% contains an equal mix of affected and normal (dry) signal.

Send 2 and Send 3 are also used to route sounds to the Sub 1 and 2 outputs on the back panel. When a plug is inserted into the associated Submix jack on the back panel, the Dry portion of the Send is disconnected from the effects processor and the Dry signal is routed directly to the output jack. The actual output routing is shown in parenthesis in the display. *The Dry Send is disconnected from the Effects Processors even if only one plug is inserted into a Submix pair.*

The Effects Send is programmed for each layer in the Edit menu. These routings can be overruled in the Master menu *Mix Output* screen by changing the submix setting from “preset”, which uses the preset routing, to Send1-Send4. In the diagram below, MIDI channel 1A is programmed to obey the preset routing which in this case is Send 1.

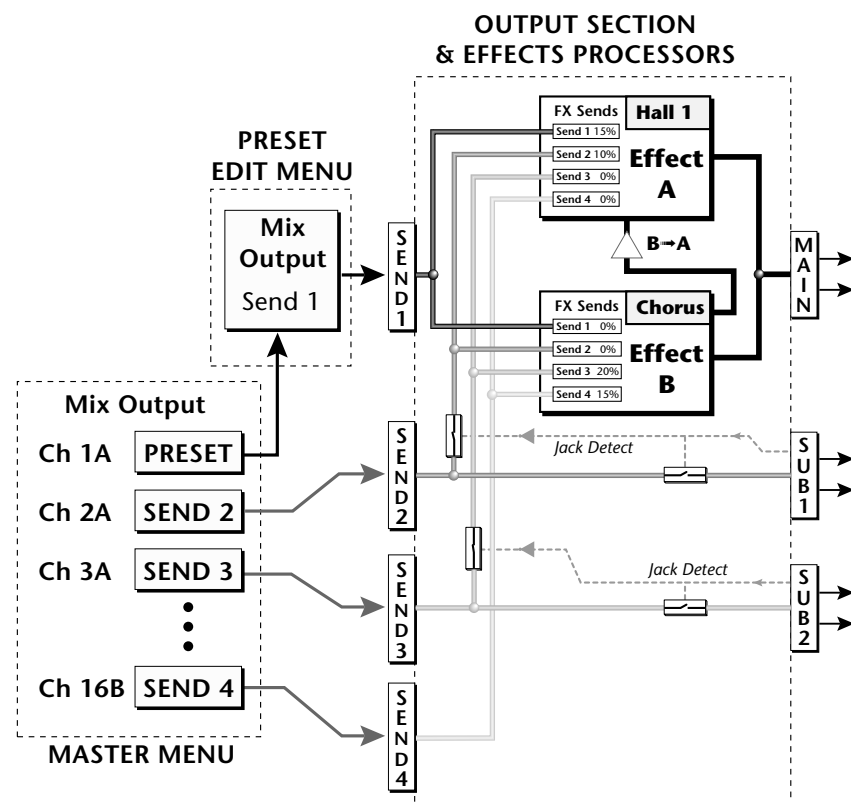

Individual layers or entire MIDI channels can be routed to any of the four busses.

The four Effect Sends allow you to get the most out of the two effect processors. For example, with Effect B set to an echo algorithm, you could route one MIDI channel to Send 3 and set the effect amount to 80%. Another MIDI channel could be routed to Send 4 with an effect amount of only 5%. This is almost like having two different effects!

The Mix Output function is also useful when sequencing since it lets you route specific MIDI channels (and thus sequencer tracks) to specific Sub outputs (on the back panel) where they can be processed with EQ or other outboard effects.



## Effect Types

### A Effect Types

Room 1-3  
Hall 1 & 2  
Plate  
Delay  
Panning Delay  
Multitap 1  
Multitap Pan  
3 Tap  
3 Tap Pan  
Soft Room  
Warm Room  
Perfect Room  
Tiled Room  
Hard Plate  
Warm Hall  
Spacious Hall  
Bright Hall  
Bright Hall Pan  
Bright Plate  
BBall Court  
Gymnasium  
Cavern  
Concert 9  
Concert 10 Pan  
Reverse Gate  
Gate 2  
Gate Pan  
Concert 11

Medium Concert  
Large Concert  
Large Concert Pan  
Canyon  
DelayVerb 1-3  
DelayVerb 4-5 Pan  
DelayVerb 6-9

### B Effect Types

Chorus 1-5  
Doubling  
Slapback  
Flange 1-7  
Big Chorus  
Symphonic  
Ensemble  
Delay  
Delay Stereo  
Delay Stereo 2  
Panning Delay  
Delay Chorus  
Pan Delay Chorus 1 & 2  
Dual Tap 1/3  
Dual Tap 1/4  
Vibrato  
Distortion 1 & 2  
Distorted Flange  
Distorted Chorus  
Distorted Double

### *Effect Parameters*

“A” Effect types contain Reverb and Delay effects. “B” Effect types contain Chorus, Flange and Distortion effects. There are 44 “A” effects and 32 “B” effects. In addition to the effect type, there are user adjustable parameters for each effect. The “A” effects have programmable Decay and High Frequency Damping. The “B” effects have user programmable Feedback, LFO Rate, and Delay Time.

### **Decay**

The Decay parameter is used when setting “A” type effects. Decay sets the length of time it takes an effect to fade out. When setting up reverb effects, Decay controls the room size and the reflectivity of the room. For larger room sizes and greater reflectivity, set the Decay value higher. When setting up delay effects, the Decay parameter controls how many echoes are produced or how long the echoes last. The greater the value, the more echoes and longer lengths of time.

The Decay value range is from 0 through 90.

### **High Frequency Damping**

The HF Damping parameter is used when setting “A” type effects. High Frequency energy tends to fade away first as a sound is dissipated in a room. The HF Damping parameter adjusts the amount of damping applied to the signal’s high frequency elements which, in turn, changes the characteristics of the room. Rooms with smooth, hard surfaces are more reflective and have less high frequency damping. Rooms filled with sound absorbing materials, such as curtains or people, have more high frequency damping.

The value range for High Frequency Damping is from 0 through 127.

### **Feedback**

The Feedback parameter is used when setting “B” type effects. The Chorus and Flange effects have a controllable feedback loop after the delay element. Feeding back a small amount of the signal intensifies the effect by creating multiple cancellations or images. Higher feedback values increase the amount of the Feedback loop.

The Feedback value range is from 0 to 127.

### **LFO Rate**

The LFO Rate parameter is used when setting “B” type effects. Both Chorus and Flange effects use a Low Frequency Oscillator (LFO) to animate the effect. LFO applied to a chorus effect creates the slight changes necessary for a realistic choral effect. Applied to a flanger effect, the LFO moves the comb filter notches and adds animation to the sound.

The LFO Rate value range is from 0 to 127.

### **Delay**

Flanging, chorus and echoes are all based on a delay line where the signal is delayed by some time period and then mixed back with the unaltered signal. This parameter specifies the how much time passes before you hear the delayed signal. On some effects, this value cannot be changed. In this case, the field contains a dash.

The Delay value range is from 0ms to 635ms.

## Effects Programmed in the Preset

Effects are normally programmed as part of the preset, allowing you to have a different effect for each. This section describes how to program and modify Vintage Pro's preset effects.

### ► To Program the Effects as Part of the Preset:

1. Press the Edit button. The LED illuminates and the Edit screen appears.
2. Use the Data Entry Control to select the FXA Algorithm screen.



3. Select an Effect. Do not select the "Master Effect" setting or the global effects set up in the Master menu will be used instead of the Preset Effect settings.
4. Use the Data Entry Control to select the FXA parameter screen.



The FxB -> FxA parameter lets you route the B effect through the A effect. See "Effect B Into Effect A" on page 182.

5. Set the other effect parameters to your preference. Refer to the information in the last section for detailed descriptions of these parameters.
6. Use the Data Entry Control to select the FXB Algorithm screen.

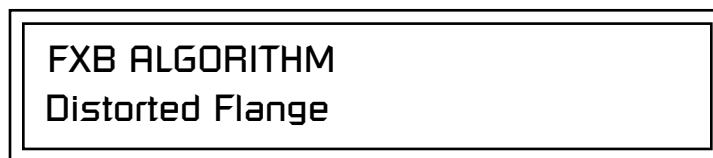

7. Select an Effect. Do not select the "Master Effect" setting or the global effects set up in the Master menu will be used instead of the Preset Effect settings.
8. Use the Data Entry Control to select the FXB parameter screen.

## Master Effects

|     |        |         |       |
|-----|--------|---------|-------|
| FXB | FEEDBK | LFORATE | DELAY |
|     | 127    | 127     | 635ms |

9. Set the other effect parameters to your preference. Refer to the information in the last section for detailed descriptions of these parameters.
10. Save the preset. The programmed effects setting will be saved along with the preset.

You might want the effects to be programmed on a global basis when in Omni or Poly modes. You could choose your favorite reverb, for example, and have it applied to any preset you select.

When playing single presets, the effects are normally programmed as part of the preset. In Multimode, the Master effects are used, since there are only two effect processors to serve 32 MIDI channels.

### ► To Program the Master Effects

1. Press the Master menu button. The LED illuminates and the Master screen appears.
2. Use the Data Entry Control to select the FXA Algorithm screen.

|                |
|----------------|
| FXA ALGORITHM  |
| Lg Concert Pan |

3. Select an Effect.
4. Use the Data Entry Control to select the FXA parameter screen.

|     |       |        |         |
|-----|-------|--------|---------|
| FXA | DECAY | HFDAMP | FxB>FxA |
|     | 90    | 127    | 127     |

The FxB -> FxA parameter lets you route the B effect through the A effect. See "Effect B Into Effect A" on page 182.

5. Set the other effect parameters to your preference. Refer to the information in the last section for detailed descriptions of these parameters.
6. Use the Data Entry Control to select the FXB Algorithm screen.



7. Select an Effect.
8. Use the Data Entry Control to select the FXB parameter screen.

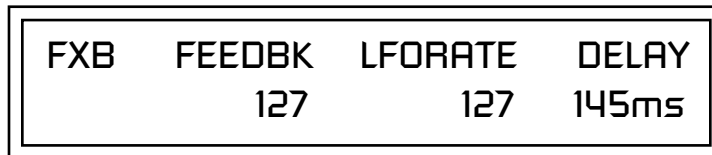

9. Set the other effect parameters to your preference. Refer to the information in the last section for detailed descriptions of these parameters.
10. Press the Edit menu button. The LED illuminates and the Edit menu displays the last screen used.
11. Use the Data Entry Control to access the FXA Algorithm page and select "Master Effect A."



*The MIDI mode (Master Menu) must be set to Omni or Poly mode in order to select the effects in the preset.*



12. Repeat step 11 for the FXB Algorithm
13. Save the preset. The Master effects routing will be saved along with the preset.

## Effects Mode

This control provides a true bypass of the effects engine. Bypass is a useful feature if you are using external effects at the mixing console and want to turn the effects off for all presets.

### ► To Bypass the Effects:

1. Press the Master menu button. The LED lights and the last Master parameter screen used is displayed.
2. Use the Data Entry Control to select the Effects Mode screen.

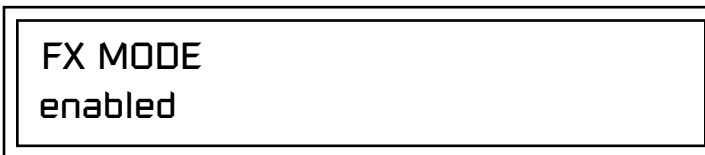

3. Use the cursor button to advance the cursor to the bottom line in the screen.
4. Use the Data Entry Control to change the value.
5. Press the Enter key to save the settings.

The Effects Mode values are “enabled” and “bypassed.” Enabling the Effects Mode turns on effects. Selecting “bypassed” turns off the effects.

## Flexible Effects Control

The effects processor controls are very flexible. The effects can be controlled in three different ways to suit your personal preference and to adapt to different situations.

When in Omni or Poly mode, effects are normally programmed as part of the preset. In Multi mode, the two effects processors can be controlled using the Master settings or by using the effects settings of a preset on a specific MIDI channel. Effects can be programmed in the following ways:

 You can create special “Effects Presets” which are assigned to the FX Multi mode Control channel, then use standard MIDI Program Change commands to switch effects during sequence playback.

1. **Programmed as part of the preset when playing single presets (Omni or Poly Modes).**
2. **Programmed from the Master Effects Section when playing either single presets (preset Effect Type set to “Master”) or when in Multi Mode.**
3. **Programmed from the designated control preset when in Multi Mode.**

Refer to the following diagram to learn how effects can be programmed.

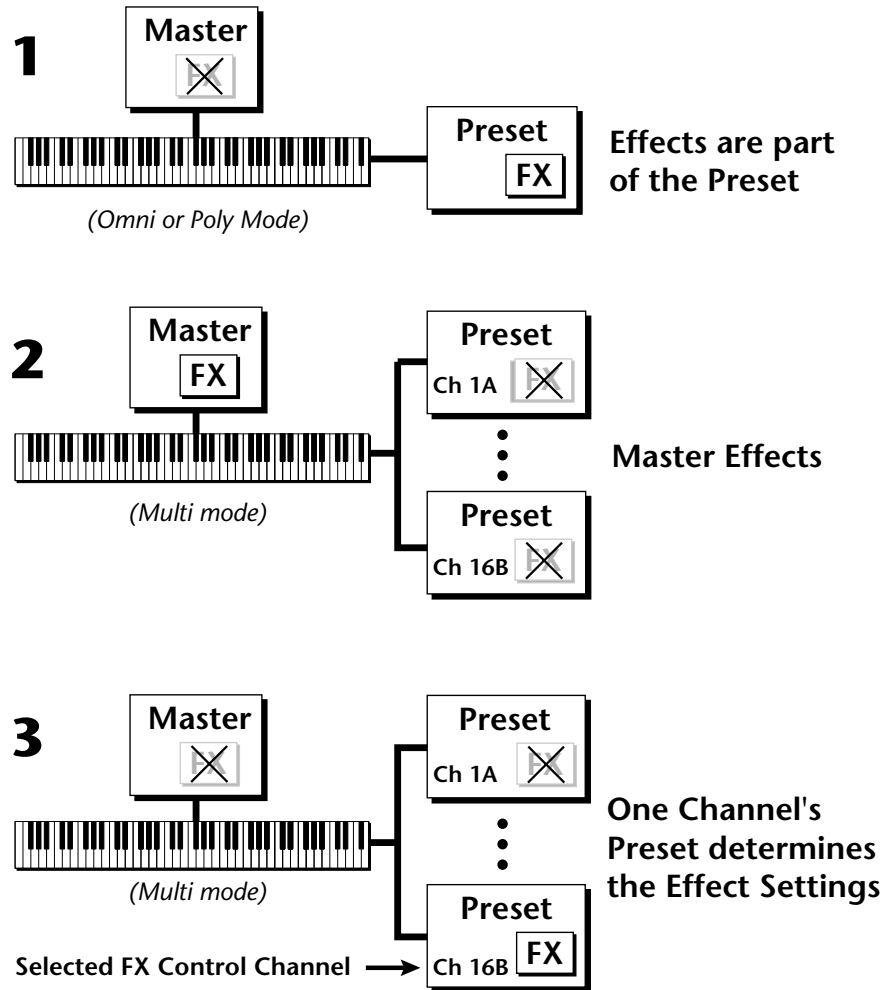

► **To Program the Effects Globally for all Presets in Multi Mode:**

1. Press the Master menu button. The LED illuminates and the Master menu screen appears.
2. Use the Data Entry Control to select the MIDI mode page. Choose "multi" for the mode.

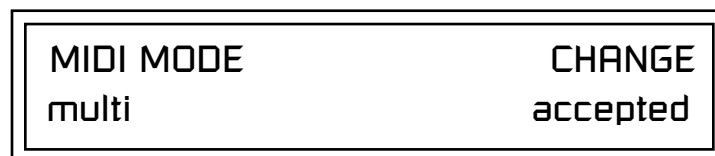

3. Move the cursor to the Multi mode Effects Control page using the Data Entry Control.

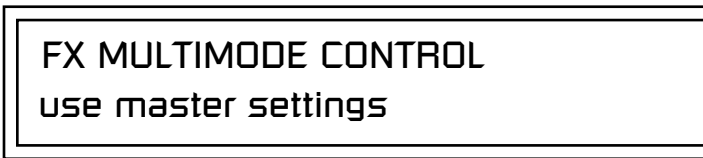

4. Set the Effect Control channel to *use master settings* using the Data Entry Control.
5. Press the Enter key to save the settings and return to the main screen.

### Using the Effects Channel Settings in Multi Mode

In Multi mode, the two effects processors can be controlled from the Master Effects settings or they can follow the effects settings of the preset on a special MIDI channel. The effect settings on this special channel will be applied to all the other MIDI channels. This allows the effects to be changed during a sequence simply by changing the preset on a specified MIDI channel.

#### ► To Program the Effects by Channel Number in Multi Mode

1. Press the Master menu button. The LED illuminates and the Master menu screen appears.
2. Use the Data Entry Control to select the MIDI mode page. Choose “multi” for the mode.
3. Move the cursor to the Multi mode Effects Control field using the Data Entry Control
4. Set the Effect Control to “preset on Channel #” (where # is replaced by the actual channel number from 1A through 16B) using the Data Entry Control.
5. Press Enter to save the settings and return to the main screen.

### Effect B Into Effect A

The output of effects processor B can be routed into effects processor A. This connects the effects in series instead of their normal parallel configuration. Two effects connected in series sound very different than the same two effects in parallel. For example, a chorus patched through reverb can turn a bland string section into a lush wall of sound. The B →A amount can also be controlled for even more flexibility.

#### ► To Send the Output of Effect B through Effect A:

In this example, 100% of Effect B will be sent into Effect A.

1. Access the FXA parameter screen (in either the Master or Edit menus) that contains the FXB →FXA parameter.



|     |       |        |         |
|-----|-------|--------|---------|
| FXA | DECAY | HFDAMP | FxB>FxA |
|     | 127   | 127    | 127     |

- Set this amount to 127. Press the cursor button to return the cursor to the top line in the display.
- Use the Data Entry Control to select the FXA submix routing parameter screen.

|                  |        |
|------------------|--------|
| FXA SEND AMOUNTS | 1: 10% |
| 2: 20%           | 3: 30% |
|                  | 4: 40% |

- Press the cursor buttons to advance the cursor to the Main field.
- Set the Main send amount to any amount other than zero.
- Press the cursor button again to return the cursor to the FXA title. Use the Data Entry Control to advance to the FXB Algorithm page.
- Select an effect.
- Advance to the FXB submix routing page and set the Main FXB send percentage to zero.
- Play the keyboard and you should hear the B Effect running through Effect A. This patch is shown below.

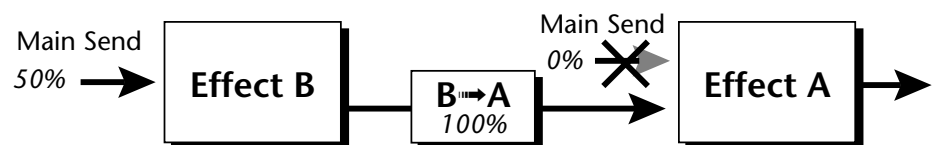

## General Effect Descriptions

### Reverb

Reverberation is a simulation of a natural space such as a room or hall. The reverb algorithms in Vintage Pro simulate various halls, rooms and reverberation plates. In addition, there are several other reverb effects such as Gated Reverbs, Multi Tap (early reflections), Delay and Panning effects. There are two adjustable parameters on the reverb effects - Decay Time and High Frequency Damping.

Decay time defines the time it takes for the reflected sound from the room to decay or die away. The diagram below shows a generalized reverberation envelope.

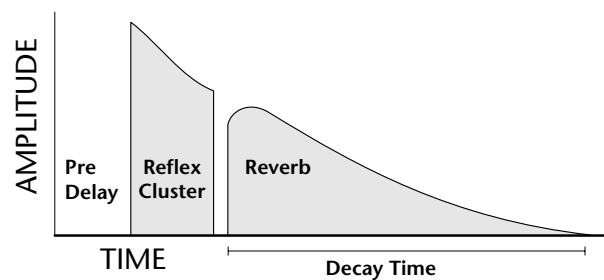

After an initial pre-delay period, the echoes from the closest walls or ceiling are heard. These first echoes, or the early reflection cluster, vary greatly depending on the type of room. Roughly 20 milliseconds after the early reflection cluster, the actual reverberation begins and decays according to the time set by the Decay Time parameter.

High frequency energy tends to fade away first as a sound is dissipated in a room. The High Frequency Damping parameter allows you adjust the amount of high frequency damping and thus change the characteristics of the room. Rooms with smooth, hard surfaces are more reflective and have less high frequency damping. Rooms filled with sound absorbing materials such as curtains or people have more high frequency damping.

#### General Descriptions of the Reverb Types

**Room:** Programs simulate small rooms with high frequency absorption caused by drapes and furniture.

**Plates:** Simulates plate type reverbs with their tight, dense, early reflections and sharp reverb buildup.

**Hall:** Presets recreate the open, spacious ambience of large concert halls.

**Gated Reverbs:** Add ambience only while the original signal is still sounding. As soon as the signal falls below a threshold, reverb is cut off.

**Delay:** Programs can be used to create echo and doubling effects.

**Multi Tap:** Programs consist of the reflection cluster only without the reverb decay.

## Chorus

The function of a chorus device is to thicken the sound or to make one voice sound like many. This effect is usually created by mixing one or more delayed versions of the signal with the original. The delay times used are too short to be perceived as an echo, but long enough so that comb filtering does not occur. In addition, the delay time is varied via a low frequency oscillator to simulate the random differences which occur when multiple instruments are playing together. A slight amount of feedback improves the effect by creating multiple images of the sound as it recirculates again and again.

All the choruses are true stereo using two separate delay lines controlled by a single set of controls. The delay times are slightly different for each channel and the LFO phase is inverted on one channel to help contribute to the overall chorus effect. The LFO Rate and Depth settings are critical to achieving a realistic effect, with faster LFO rates generally requiring less LFO amount and vice-versa.

## Doubling

When a copy of a sound delayed by about 26 milliseconds is added back to the original, two audio images are perceived by your brain. When the delayed image is slightly varied or modulated, the illusion of two voices is created.

## Slapback

Slapback is a single short echo in the range of 50-60 milliseconds. A sound delayed by this length of time is perceived as a discrete and separate image which is useful for a thickening effect or as a pre-delay for reverb simulating a hard, reflective surface such a gymnasium wall.

## Stereo Flanger

A flanger consists of a short audio delay line whose output is mixed together with the original signal. Mixing the delayed and original signals results in multiple frequency cancellations called a comb filter. Since the flanger is a type of filter, it works best with harmonically rich sounds.

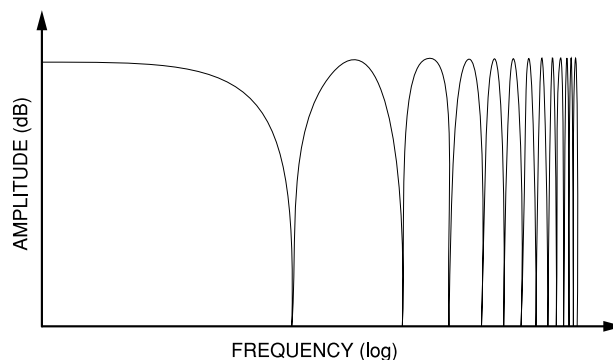

This is the frequency response of a Comb Filter.

Flanging was originally created using two tape recorders playing identical recordings. By exactly synchronizing the two decks and then slowing the speed of one by grasping the tape reel flanges, the flanging effect was born.

The Vintage Pro flanger is a stereo device consisting of two separate delay lines controlled by a single set of controls. A Low Frequency Oscillator (LFO) varies this initial delay setting, changing the frequency of the notches and adding animation to the sound. LFO Rate controls the rate of change and LFO Depth controls how much the LFO changes the delay.

The Feedback control sends some of the delayed signal through the delay line again. When feedback is used the comb filter notches are deepened.

### *Delay*

Delay is an effect which can be used for doubling, reverb pre-delay, or echoes.

Delay Time is variable from 0-635 mS and controls the time between echoes. Feedback and determines how long the echoes continue sounding. "Infinite" delay effects are also possible without the risk of runaway.

### *Stereo Delay*

Similar to delay except that the delay line outputs a stereo signal from the mono input. The two output signals are a few milliseconds apart to create a stereo image. The delay times are variable from 0-635 mS.

### *Panning Delay*

A panning delay is similar to the normal delay lines except that the echoes bounce back and forth between the two stereo speakers.

### *Dual Tap*

These are delay lines where the signal is "tapped off" at two unevenly spaced locations. When feedback is used, multiple complex echoes are produced. The fraction in some of the algorithm names (i.e. 1/3, 1/4) refers to the time ratio between the taps.

### *Vibrato*

Basically, this a delay line modulated by an LFO, but with none of the original signal added in. The LFO modulation creates a Doppler shift and a resultant cyclical pitch shift. The vibrato created in this manner sounds very different than vibrato created by frequency modulating the sample.

### *Distortion*

Distortion uses a technique called "soft-clipping" to create additional harmonics in the signal. As the level increases, the top of the waveform becomes somewhat squared. As the level increases further, it transforms into a true square wave.



Soft clipping gradually squares the edges of the waveform as the amplitude is increased.

# Save/Copy Menu

## Saving a Preset



*Each time you change a preset parameter, the Save/Copy button LED illuminates reminding you to save your work.*

The Save/Copy menu is used to save changes to a preset and to copy data between presets. The menu also contains a tool to create random presets.

The important **Multisetup** parameters are also located here. A Multisetup is a group of parameters that you might associate with a particular sequence or song. It is like a “snapshot” of the current MIDI channel configuration of the module. There are 64 setups numbered 0-63. Multisetups 0-62 are user programmable. Multisetup 63 is the default Factory Multisetup.

When in “Quick Edit” mode, this menu always defaults to the “Save to Preset” page of this menu with the cursor on the second line. You can use the Data Entry Control to navigate to other pages that support copying information.

Any time you make a change to a preset, either using the Edit menu or by changing the Controller Knobs in Quick Edit mode, you must save the preset in order for the change to become permanent. When you save a preset it erases any existing preset information in that location. Make sure that the destination location does not contain preset information you want to keep.

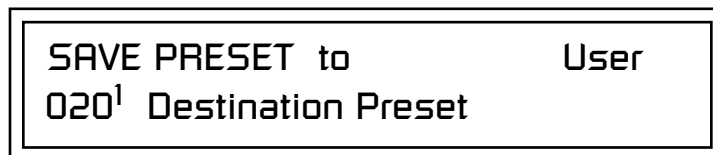

### ► To Save a Preset

1. Press the Save/Copy menu button.
2. Scroll to the Save Preset screen using the data entry control.
3. Move the cursor to the bottom line on the display.
4. Select the new preset location using the Data Entry Control.
5. Press the Enter/Home button.

## Copying Information

The Copy operations let you copy information from any preset or layer to any other preset or layer. To use the copy command, first select the preset or layer to which you want to copy (the destination location). Then, from the copy screen, select the preset or layer you want to copy to the currently selected location (the source location). Using the copy commands you can copy preset, layer, PatchCord and arpeggiator information.

### Copy Preset

The Copy Preset command lets you copy all of the preset information from one location into the preset of the current location. The preset information in the source location (the preset location from which you want to copy) is not deleted from the original location, just copied to the destination location.

```
COPY PRESET from      VROM
0093  pad: Dreamer
```



All the Sound Navigator features work when using the Copy functions.

#### ► To Copy a Preset

1. Select the Preset you want to copy information *into*.
2. Press the Save/Copy menu button.
3. Scroll to the Copy Preset screen using the data entry control.
4. Select "Copy Preset from" using the Data Entry Control.
5. Select the preset you want to copy using the Data Entry Control. The ROM Bank, Preset Number, Bank Number, Category and Preset Name fields are all selectable.
6. Press the Enter/Home button.
7. A warning screen appears asking you to confirm once more. Press the Enter/Home button to copy the selected preset into the current location.

### Copy Layer

The Copy Layer command lets you copy any layer information from one preset into any layer of the current preset location. The layer information in the source location (the layer location from which you want to copy) is not deleted from the original location, just copied to the destination location.

```
COPY LAYER   User      L1 -> L4
0201       : Source Preset
```

*Copy  
PatchCords*

► **To Copy a Layer**

1. Select the Preset and Layer you want to copy information into.
2. Press the Save/Copy menu button.
3. Scroll to the Copy Layer screen using the data entry control.
4. Move the cursor to the bottom line on the display.
5. Select the preset location using the Data Entry Control, of the preset containing the information you want to copy into the current preset.
6. Move the cursor to the top line in the display.
7. Select the layer of the source preset in the first field on the right.
8. Select the destination layer in the second field.
9. Press the Enter/Home button.

The Copy PatchCord command lets you copy the patchcord settings from one layer of the preset location into the current layer of the current preset location. The preset information in the source location (the preset location from which you want to copy) is not deleted from the original location, just copied to the destination location.

```
COPY CORDS   User   L1 -> L4
0201       : Source Preset
```

► **To Copy a PatchCord**

1. Select the Preset and Layer you want to copy information into.
2. Press the Save/Copy menu button.
3. Scroll to the Copy Cords screen using the data entry control.
4. Move the cursor to the bottom line on the display.
5. Select the preset location using the Data Entry Control, of the preset containing the information you want to copy into the current preset.
6. Move the cursor to the top line in the display.
7. Select the layer of the source preset in the first field on the right.
8. Select the destination layer in the second field.
9. Press the Enter/Home button.

## Copy Preset PatchCords

The Copy Preset PatchCord command lets you copy the preset patchcord settings from one preset location into the current preset location. The preset information in the source location (the preset location from which you want to copy) is not deleted from the original location, just copied to the destination location.

```
COPY PRESET CORDS      User
0201      : Source Preset
```

### ► To Copy a Preset PatchCord

1. Select the Preset you want to copy information into.
2. Press the Save/Copy menu button.
3. Scroll to the Copy Preset Cords screen using the data entry control.
4. Move the cursor to the bottom line on the display.
5. Select the preset containing the information you want to copy.
6. Press the Enter/Home button.

## Copy Arpeggiator Settings

This function lets you copy the Arpeggiator settings from any ROM or RAM preset location into the current RAM (User) preset.

```
COPY ARP SET from      VROM
0520 syn: Syn Chaos
```

### ► To Copy the Arpeggiator Settings:

1. From the Main display, **select the User Preset** you want to copy the Arp setting *into*.
2. Press the **Save/Copy** menu button.
3. Move the cursor to any of the fields on the bottom line on the display.
4. Use the data entry control to **select the preset** you want to copy *from*.
5. Press **Enter** when you have made your selection. *The Enter LED is flashing indicating that Vintage Pro is waiting for your response.*
6. The Arp Settings are copied into the current preset.



## Copy Arpeggiator Pattern

This function lets you copy the Arpeggiator pattern from any ROM or RAM preset to any RAM (user) pattern.



COPY ARP PAT from VROM  
96<sup>1</sup> TRANCED

### ► To Copy the Arpeggiator Pattern:

1. Press the **Save/Copy** menu button.
2. Move the cursor to any of the fields on the bottom line on the display.
3. Use the data entry control to **select the preset** you want to copy *from*.
4. Press **Enter** when you have made your selection.



Overwrite pattern:  
00<sup>0</sup> No Control

5. Press **Enter**. The Arp Pattern is copied into the selected User Pattern.

## Copy Preset Bank

The Copy Preset Bank command lets you copy an entire bank from any ROM or RAM bank location to any RAM (user) bank. This function can be especially useful after installing a new sound SIMM.

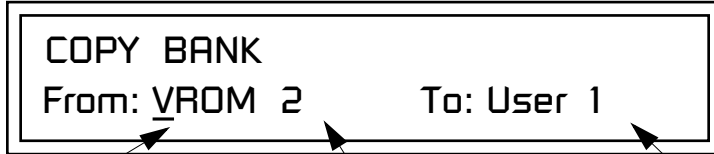

COPY BANK  
From: VROM 2 To: User 1

ROM or RAM  
Preset Location

Bank No.

Destination  
Bank No.

### ► To Copy a Preset Bank

1. Press the **Save/Copy** menu button.
2. Scroll to the Copy Preset bank screen using the data entry control.
3. Move the cursor to the “From” field on the bottom line on the display.
4. Use the Data Entry Control to select the preset bank you want to copy *from*.
5. Move the cursor to the “To” field on the bottom line on the display.
6. Use the Data Entry Control to select the User preset bank you want to copy *into*.
7. Press the **Enter/Home** button to overwrite the bank.

# Multisetups

**A Multisetup includes ALL the following parameters:**

- Preset/Volume/Pan assignments for each of the 32 MIDI channels.
- Multisetup Name
- ALL MASTER MENU PARAMETERS except...
- MIDI Program Change->Preset map
- User Key Tuning Tables



Multisetups can also be restored (selected) via MIDI Bank and Program change commands. Select: cc00 = 80, cc32 = 00, (dec) then send a Program Change command corresponding to the Multisetup you wish to select.

## Restoring Multisetups

Vintage Pro contains 64 Multisetup locations. 63 of these are User locations which you can use to store your own Multisetups.

Multisetups can also be restored using a MIDI Bank Select command. Select: cc00 = 80, cc32 = 00, (dec) then send a Program Change command corresponding to the Multisetup you wish to select.



### ► To Restore (Select) a Multisetup:

1. Press the **Save/Copy** menu button lighting the LED. The Save/Copy menu screen displays the menu page most recently selected since powering up Vintage Pro. The cursor appears below the first character of the screen heading on line one.
2. Go to the "Restore Multisetup" screen (shown above) using the Data Entry Control.
3. Press either cursor button to move the cursor to the bottom line of the screen.
4. Now, use the Data Entry Control to select a Multisetup. The Enter LED will be flashing.
5. Press the Enter button to load the selected Multisetup.

## Multisetup Name

Multisetups can be named to make it easier to remember their purpose.

1. Scroll to the “Setup Name” screen (shown below) using the **data entry control**.

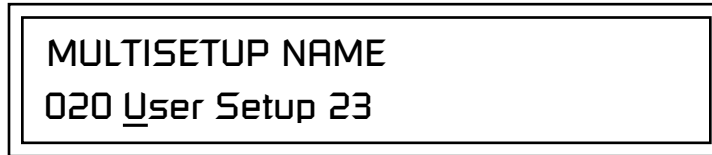

2. Press either **cursor** button to move the cursor to the bottom line of the screen.
3. Change the characters using the **data entry control**. Change the cursor position using the cursor buttons.
4. Press **Enter** or move the cursor to the top line when you're finished naming the multisetup.

## Saving Multisetups

### ► To Save a Multisetup:

1. Set the Preset, Volume, Pan settings the way you want them for all 32 channels. Set the Master menu parameters the way you want them.
2. Press the **Save/Copy** menu button lighting the LED.
3. If you wish to Name your new Multisetup continue on, otherwise skip to step 8.
4. Scroll to the “Setup Name” screen using the Data Entry Control.

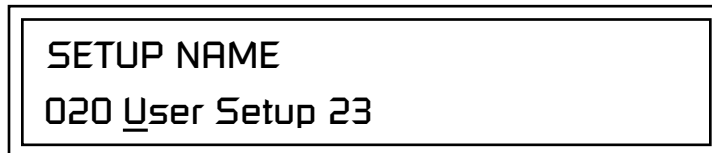

5. Press either cursor button to move the cursor to the bottom line.
6. Scroll to the “Save Multisetup” screen (shown below) using the Data Entry Control.



7. Press either cursor button to move the cursor to the bottom line.
8. Now, use the Data Entry Control to select the destination location. The Enter LED will be flashing.
9. Press the Enter button to save the Multisetup.

## Create Random Preset

This is a great feature which creates a new preset using portions of the ROM presets as source material. By merging random presets, really great sounding presets can be generated with ease. Use this feature to generate wild new sounds, get new programming ideas or just for fun.



*Examine interesting  
presets to learn how they work  
using the Edit menu.*

### ► To Create a Random Preset:

1. Press the **Save/Copy** menu button.
2. Move the cursor to the bottom line on the display and press **Enter**.
3. A new random preset will be created.
4. Don't like the sound? Press **Enter** again to create a new random sound.

## Sound Authoring

### Copy User Bank to Flash



If there is no Flash SIMM in the unit, the error message, "Requires Flash SIMM" will be displayed.

This is a special purpose function to be used with the Flash sound authoring feature. Flash Sound SIMMs created on an EOS Ultra sampler can be used as a custom Vintage Pro bank. Presets are then created in a User bank. When the bank of presets is finished, it can be copied, using this function, to the Flash SIMM. Flash SIMMs contain two separate memory locations. One of these memories contains the sound samples and the other memory can hold four banks of 128 presets.

**For instructions on how to remove and replace ROM SIMMs, please see "Installing Sound SIMMs" on page 216.**

The four sound SIMM sockets in Vintage Pro are marked 0-3. **The destination Flash SIMM must be placed in SIMM socket 1.**

**COPY USER BANK TO FLASH**  
From: User<sup>0</sup>      To: Flash<sup>2</sup>

#### ► To Copy a User Bank to Flash:

1. Make sure a Flash SIMM is inserted into the extra Vintage Pro SIMM socket.
2. Press the **Save/Copy** menu button.
3. Rotate the data entry control to select the "Copy User Bank" function shown above.
4. Move the cursor to the "From" field and select the User bank that you want to copy to the Flash SIMM.
5. Move the cursor to the "To" field and select the Flash bank that you want to contain the User bank.
6. Press **Enter**. The Enter LED will flash and the screen below appears.

**Press ENTER to Overwrite  
Flash SIMM Presets**

7. Press **Enter** again to confirm. The following screen appears:

**COPYING USER BANK TO FLASH  
Done. Please Reboot Now.**

8. The Flash presets cannot be used until Vintage Pro is rebooted (power off then on). **Reboot** the Vintage Pro and verify that the new Flash bank has been properly copied.

## Rename Flash SIMM



The Flash ID is the MSB of the MIDI Bank Select command used to select the Sound Bank.



If there is no Flash SIMM in the unit, the error message, "Requires Flash SIMM" will be displayed.

This utility allows you to rename the Flash SIMM and change its ID number. Flash SIMMs can have any five letter name you choose. Each Flash SIMM in a Vintage Pro unit must have a unique ID number (106-119).

The field in the upper right corner selects between multiple Flash SIMMs. If only one Flash SIMM is installed, the field cannot be modified.

|                   |         |
|-------------------|---------|
| RENAME FLASH SIMM | Flash   |
| New Name: Drums   | ID: 110 |

1. Make sure a Flash SIMM is inserted in a Vintage Pro SIMM socket.
2. Press the **Save/Copy** menu button.
3. Rotate the data entry control to select the "Rename Flash SIMM" function shown above.
4. Move the cursor to the "New Name" field and rename the SIMM using the data entry control to select the letter and the cursor keys to select the position.
5. **Set the Sound ID number** for the SIMM. It doesn't matter which number you choose as long as the same number isn't used in another SIMM.
6. Press **Enter**. The following screen appears and the Enter LED will be flashing.

|  |
|--|
| Press ENTER to Update<br>Flash SIMM data |
|--|

7. Press **Enter** again to confirm or any other button to abort. The following screen appears:

|  |
|--|
| CHANGING SIMM NAME & ID<br>(takes about 2 minutes) |
|--|

8. The Flash presets cannot be used until Vintage Pro is rebooted (power off then on). **Reboot** Vintage Pro and verify that the new Flash bank has been properly renamed.

## Duplicate Flash



*If there are no Flash SIMMs in the unit, or if the SIMMs are in the wrong slots, an error message will be displayed.*

This utility allows you to duplicate Flash SIMMs using Vintage Pro. Both Sound and Preset data is copied when a Flash SIMM is duplicated. A factory sound SIMM cannot be copied using this utility.

The SIMM sockets are marked 0, 1, 2, 3. The Flash SIMM you want to copy **MUST** be placed into SIMM Socket 0. The destination Flash SIMM must be placed in SIMM socket 1. See “Installing Sound SIMMs” on page 216.

DUPLICATE SLOT 0 FLASH  
Start

1. Make sure the two Flash SIMM are located in the required SIMM sockets.
2. Press the **Save/Copy** menu button.
3. Rotate the data entry control to select the “**Duplicate Flash SIMM**” screen shown above.
4. **Move the cursor** to the bottom line and press **Enter**. The following screen appears and the Enter LED will be flashing.

Press ENTER to overwrite  
the Flash SIMM in Slot 1

5. Press **Enter** again to confirm or any other button to abort. The following screen appears and the SIMM is copied.

DUPLICATING SLOT 0 -> SLOT 1  
(Takes about 5 minutes)

6. When Vintage Pro has finished duplicating the SIMM, turn power off, remove the copied SIMM, then **reboot**. That’s it!





# Appendix

## Front Panel Knob Functions

### Basic Preset Knob Functions

This section provides some of the technical information about Vintage Pro. In addition to the preset, instrument and riff listings, you will find information about velocity curves, MIDI commands and PatchCord charts.

The front panel knob functions are standardized for most of the factory presets. The typical functions of the controller knobs are described below.

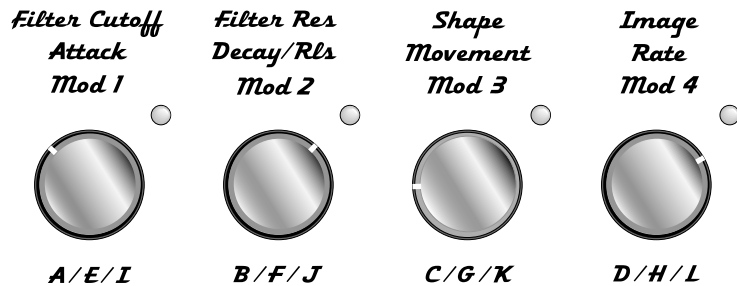

- Filter Cutoff ..... Filter Frequency
- Filter Res ..... Filter Resonance
- Shape ..... Filter Envelope Amount
- Image ..... Typically brings in additional layers
- Attack ..... Volume or Filter Envelope Attack
- Decay/Release ..... Vol/Filt. Envelope Release and/or Decay
- Movement ..... LFO->Dynamic Movement (i.e.panning)
- Rate ..... LFO Rate
- Mod 1 ..... Typically Velocity -> Amplifier Volume
- Mod 2 ..... Typically Velocity -> Filter Frequency
- Mod 3 ..... Typically Effects Processor A Amount
- Mod 4 ..... Typically Effects Processor B Amount

*Beat Preset  
Knob Function*

**Movement**..... Beats Busy  
**Rate** ..... Beats Variation

*Arp Preset  
Knob Function*

**Movement**..... Arp Gate  
**Rate** ..... Arp Rate

## Presets

Vintage Pro comes standard with 512 ROM presets and 512 editable User preset locations. Presets are organized into banks of 128 presets each. User banks 0-3 are duplicates of VROM banks 0-3.

*Preset Categories*

The Vintage Pro presets are organized in categories according to the types of sound. Listed below are the categories and their three letter prefixes:

|   |   |
|---|---|
| <b>arp:</b> Arpeggiator preset            | <b>kit:</b> Drum Kit                        |
| <b>bpm:</b> Tempo-based, LFO/Envs         | <b>led:</b> Leads                           |
| <b>bas:</b> Bass instruments              | <b>org:</b> Organs                          |
| <b>brs:</b> Brass instruments             | <b>pad:</b> Sustained, ethereal sound       |
| <b>bts:</b> BEATs preset                  | <b>prc:</b> Percussion instrument           |
| <b>cmb:</b> Combination of instruments    | <b>sfx:</b> Sound Effect                    |
| <b>epo:</b> Electric Piano                | <b>str:</b> Strings (violins, cellos, etc.) |
| <b>gtr:</b> Guitar                        | <b>syn:</b> Synthesizers                    |
| <b>jam:</b> Play along with Audition Riff | <b>vox:</b> Vocals                          |
| <b>key:</b> Keyboard variations           | <b>wnd:</b> Wind instruments                |

## Preset Listing

### User Bank 0, VROM Bank 0

- |                      |                      |                       |
|----------------------|----------------------|-----------------------|
| 0. syn:Vintage       | 43. epo:String EP    | 86. key:Phase Clav3   |
| 1. epo:Classic EP    | 44. epo:MetalBars    | 87. key:TwoClavs      |
| 2. epo:CP Seventy    | 45. epo:MetalBarsXfd | 88. key:ThinClav      |
| 3. epo:Wurly         | 46. epo:EP Silver    | 89. key:Clavsichord   |
| 4. key:Clavinet      | 47. epo:Canada       | 90. key:Monster Clav  |
| 5. org:B-3 OvrDrive  | 48. epo:Toyo         | 91. key:AnaClav       |
| 6. epo:Mello Tines   | 49. epo:MarshMello   | 92. key:Klav Mav      |
| 7. vox:BigTronChoir  | 50. epo:Mello EP1    | 93. key:WakTclav      |
| 8. led:BeginAgain    | 51. epo:Mello EP2    | 94. key:Clav Freak    |
| 9. bas:TaurusPedals  | 52. epo:Mellow Pop   | 95. key:Kloid's Jam   |
| 10. str:Tron Violins | 53. epo:OB Tine EP   | 96. key:Clav Wah 1    |
| 11. brs:'99 Brass    | 54. epo:OB EP        | 97. key:Clav Wah 2    |
| 12. syn:SEM          | 55. epo:FM Tines     | 98. key:Clavicle      |
| 13. syn:Airscopix    | 56. epo:FM SimpleEP  | 99. key:P5Hrpsichrd   |
| 14. syn:OB Glider    | 57. epo:FM Delicate  | 100. key:Clavitzer    |
| 15. kit:Electra      | 58. epo:FM Phase     | 101. org:All Out      |
| 16. syn:Analogic     | 59. epo:FM Flanger   | 102. org:1st3 2ndPerc |
| 17. epo:Dyno Vox     | 60. epo:Dynamic FM   | 103. org:1st3 3rdPerc |
| 18. epo:CP Pad       | 61. epo:Analog FM    | 104. org:1st4 Vib     |
| 19. org:Jazz Pro     | 62. epo:Wurlilayer   | 105. org:1st4Vib2Perc |
| 20. key:Clav Flanger | 63. epo:Mama'sWurli  | 106. org:1st4Vib3Perc |
| 21. org:Old Red Top  | 64. epo:Real CP      | 107. org:Six Out      |
| 22. pad:Sentinels    | 65. epo:ClassicCP    | 108. org:Jazz'n Jimmy |
| 23. vox:Light Aahs   | 66. epo:CP 70        | 109. org:1st3HiDrBr   |
| 24. syn:Back at U    | 67. epo:CP Layer     | 110. org:1st3FullDist |
| 25. bas:Mini Snap    | 68. epo:Vintage CP   | 111. org:1st4VFullDis |
| 26. cmb:Flute/String | 69. epo:Rock CP      | 112. org:Pipe Organ   |
| 27. brs:Thick Brass  | 70. epo:Stage CP     | 113. org:Far Away     |
| 28. syn:Synth Stack  | 71. epo:CP Light     | 114. org:Clicky       |
| 29. syn:OB-Xa        | 72. epo:CP Tight     | 115. org:Comp         |
| 30. brs:Tron Brass   | 73. epo:CP Uptown    | 116. org:PortaVib     |
| 31. kit:FusionMover  | 74. epo:Lullaby      | 117. org:PortaVibSt   |
| 32. epo:Dyno Piano   | 75. epo:AOR Ballad   | 118. org:Shimmer      |
| 33. epo:Chorus Dyno  | 76. key:Clav 1       | 119. org:OBX Organ    |
| 34. epo:Lite Dyno    | 77. key:Clav 2       | 120. org:PlasticOrg   |
| 35. epo:Heavy Dyno   | 78. key:Clav 3       | 121. org:MelloCombo   |
| 36. epo:StudioDyno1  | 79. key:Clav1&2      | 122. org:BrashCombo   |
| 37. epo:StudioDyno2  | 80. key:StereoClav 2 | 123. org:ComboTrem    |
| 38. epo:DynoStcase   | 81. key:Buzzy Clav   | 124. org:Dr. Please   |
| 39. epo:DynoChorus   | 82. key:FunkMaster   | 125. org:Grindo       |
| 40. epo:Stereo EP    | 83. key:PhaseClav    | 126. org:Smooth       |
| 41. epo:DynoOdd      | 84. key:SynthClav    | 127. org:Perc Three   |
| 42. epo:Dyno Soft    | 85. key:PhaseClav2   |                       |

Preset Listing

User Bank 1, VROM Bank 1

- |                      |                      |                       |
|----------------------|----------------------|-----------------------|
| 0. syn:Wide OB       | 43. syn:Robot ca1960 | 86. syn:Sawphony      |
| 1. syn:P10           | 44. syn:Glass Pipe   | 87. syn:AnalogBell    |
| 2. syn:Juno          | 45. syn:Merlot       | 88. syn:D Fiftease    |
| 3. syn:Rogue         | 46. syn:AirCommand   | 89. syn:VS Ghost      |
| 4. syn:Huge SEM      | 47. syn:Ex-plorer    | 90. syn:Now & Zen     |
| 5. syn:Round Mini    | 48. syn:Sneaker Flap | 91. syn:Metasynth1    |
| 6. syn:Big Mini      | 49. syn:Poly Mono    | 92. syn:Metasynth2    |
| 7. syn:Juno Pulse    | 50. syn:Angel Eyes   | 93. led:Sonic Six     |
| 8. syn:10101         | 51. syn:Little       | 94. led:Muddy Sync    |
| 9. syn:Profit/Loss   | 52. syn:Lush         | 95. led:RhaspyClickr  |
| 10. syn:FuzzBell     | 53. syn:OBeast Sync  | 96. led:BigSoloSqr    |
| 11. syn:Random OB    | 54. syn:ArmyOJunos   | 97. led:Pulse         |
| 12. syn:Phase1Alert  | 55. syn:OB Saw Octs  | 98. led:M12           |
| 13. syn:JX Oct Split | 56. syn:Wall O Saws  | 99. led:OBX SyncMono  |
| 14. syn:JunoOctSplit | 57. syn:TouchRez     | 100. led:PortaLead    |
| 15. syn:Syrupy JP    | 58. syn:X Tron       | 101. led:Power Mini   |
| 16. syn:ProphetPiano | 59. syn:Shade Pad    | 102. led:WickedSquare |
| 17. syn:ArpClarinet  | 60. syn:Total Recall | 103. led:OverDrive101 |
| 18. syn:JupyPad      | 61. syn:Ice Eyes     | 104. led:Frank Stein  |
| 19. syn:MoogShrtPuls | 62. syn:Enchanted    | 105. led:Odd Lead     |
| 20. syn:Poly ARP     | 63. syn:Chimelope    | 106. led:Soft&Round   |
| 21. syn:SEM Bat Fuzz | 64. syn:S&Holding    | 107. led:Glass Rim    |
| 22. syn:Juno & DX    | 65. syn:Runner       | 108. led:Spike        |
| 23. syn:Deep Sky     | 66. syn:Weild 5ths   | 109. led:Oh Boy       |
| 24. syn:80zFuzzPad   | 67. syn:NightTime    | 110. led:JunoOvrDrive |
| 25. syn:P10 SkySweep | 68. syn:Perc Rouge   | 111. led:OB Lead      |
| 26. syn:Nephilim     | 69. syn:MiniSaw Octs | 112. led:Mean Wheel   |
| 27. syn:P5 PolySync  | 70. syn:ProFive Octs | 113. led:PulseFlanger |
| 28. syn:OB Glider2   | 71. syn:Arp Octs     | 114. led:Zawi         |
| 29. syn:Power Juno   | 72. syn:Modular Octs | 115. led:Stinger      |
| 30. syn:OBSEMFuzz1   | 73. syn:Mucho Octs   | 116. led:Raspy        |
| 31. syn:OBSEMFuzz2   | 74. syn:RogueSawOcts | 117. led:Mini Soul    |
| 32. syn:Vin Syn      | 75. syn:SySaPhUs     | 118. led:SawsOfOld    |
| 33. syn:Regbit       | 76. syn:P5 Sync 1    | 119. led:ThinPotent   |
| 34. syn:Stabber      | 77. syn:P5 Sync 2    | 120. led:OB Pulser    |
| 35. syn:Distant      | 78. syn:P5 Sync 3    | 121. led:Full Body    |
| 36. syn:Synth Ringer | 79. syn:Morpheus     | 122. led:Squawky OB   |
| 37. syn:Late 80z     | 80. syn:Synphonix 1  | 123. led:Skware!!     |
| 38. syn:Late 80z 2   | 81. syn:Synphonix 2  | 124. led:GrowlySynth  |
| 39. syn:NoteOffChime | 82. syn:KotoRize     | 125. led:Big ARP      |
| 40. syn:Nunzio       | 83. syn:Arp Axxe     | 126. led:E-MU Modular |
| 41. syn:FiltrBrass1  | 84. syn:Sin Brass    | 127. led:Funky Junk   |
| 42. syn:FiltrBrass2  | 85. syn:Megasync     |                       |

Preset Listing

User Bank 2, VROM Bank 2

|                      |                      |                       |
|----------------------|----------------------|-----------------------|
| 0. pad:ChifferPad    | 43. str:Old Time2    | 86. wnd:Floating      |
| 1. pad:Thin Lad      | 44. str:Old Time3    | 87. wnd:Dark Satyr    |
| 2. pad:Lunar         | 45. str:String Vox   | 88. wnd:Reedy         |
| 3. pad:Believe       | 46. str:String Flute | 89. cmb:Produکشun     |
| 4. pad:Angel Eyes    | 47. str:VeloBows     | 90. cmb:CP/Strings    |
| 5. pad:PreSamplers   | 48. str:String Box   | 91. cmb:FM/Strings    |
| 6. pad:Sentinels2    | 49. str:Elka & Mtron | 92. cmb:EPJunoTron    |
| 7. pad:Ghost Vox     | 50. str:Celli Sect   | 93. cmb:Juno/P5       |
| 8. pad:O.D.          | 51. str:Smooth&Wide  | 94. cmb:TronVoxStrng  |
| 9. pad:Liquid 1      | 52. str:String Fever | 95. cmb:Str & Brass   |
| 10. pad:Liquid 2     | 53. str:Its The Pitz | 96. cmb:Dyno B to B   |
| 11. pad:Liquid 3     | 54. str:ClosetCleanR | 97. cmb:Flute&String  |
| 12. pad:Beauteous    | 55. str:String Cheez | 98. cmb:B3/EP         |
| 13. pad:ProfitMargin | 56. str:Filtron      | 99. cmb:PulseMadness  |
| 14. pad:Tri Res      | 57. vox:Tron Males   | 100. cmb:Rogue Mini   |
| 15. pad:QuietSaws    | 58. vox:Cluttex      | 101. cmb:Taurus&Strng |
| 16. pad:Lunar 2      | 59. vox:SnowBound    | 102. cmb:TarusStngVox |
| 17. pad:Slippery     | 60. vox:Chiffer      | 103. cmb:Gymnosticks  |
| 18. pad:Matches      | 61. vox:BreathBlow 2 | 104. cmb:Wurli & Roti |
| 19. pad:Poly Pad     | 62. vox:TronMalesSt  | 105. cmb:Dyn Logic    |
| 20. pad:iBubble      | 63. vox:TronMixSt    | 106. cmb:TV Stack     |
| 21. pad:M12 Skyline  | 64. vox:VS Ghost     | 107. cmb:Wurly B      |
| 22. pad:Raindance    | 65. vox:ThroatEnergy | 108. cmb:SynStr+SynBs |
| 23. pad:Horizons     | 66. vox:TalkBox Pro  | 109. cmb:Many Junos   |
| 24. pad:Big Pad      | 67. vox:Moon Flute   | 110. cmb:80sStackBass |
| 25. pad:SlitherPad   | 68. brs:FullTrnBrass | 111. cmb:GtrStrings   |
| 26. pad:HarshSwell   | 69. brs:WindyBrass   | 112. cmb:C P R        |
| 27. pad:Grainy       | 70. brs:E2 Brass     | 113. cmb:MachineHeart |
| 28. pad:GrimFemVox   | 71. brs:Big Swell    | 114. jam:DX Style     |
| 29. pad:Pipey        | 72. brs:Big Swell 2  | 115. jam:CP Stage     |
| 30. pad:Organ Synth  | 73. brs:Rich Brass   | 116. jam:Clav         |
| 31. pad:Fem Strings  | 74. brs:ElegantBrass | 117. jam:Lush         |
| 32. str:MemMoogStrng | 75. brs:F-Hrns       | 118. jam:Latin        |
| 33. str:Solina       | 76. brs:Coronation   | 119. jam:Funkersize   |
| 34. str:Elka Combo   | 77. brs:HugeOB Brass | 120. bpm:Beat Row 1   |
| 35. str:SuperElka    | 78. brs:BrassKicker  | 121. bpm:Beat Row 2   |
| 36. str:Lush70'sFade | 79. brs:Brassitude   | 122. bpm:Spinner      |
| 37. str:Big M12      | 80. wnd:StereoMtron  | 123. bpm:El Effo Sr.  |
| 38. str:Ensemble     | 81. wnd:Flute Sect   | 124. bpm:Q Noiz Klock |
| 39. str:Muffled      | 82. wnd:Tron Flute   | 125. bpm:S/H Operator |
| 40. str:Sepiatone    | 83. wnd:Flute Bed    | 126. bpm:Q PulseKlock |
| 41. str:Analog Harp  | 84. wnd:SoftFlutes   | 127. bpm:RoboJive     |
| 42. str:Old Time1    | 85. wnd:LoFi Flute   |                       |

Preset Listing

User Bank 3, VROM Bank 3

|                      |                      |                       |
|----------------------|----------------------|-----------------------|
| 0. bas:Big Taurus    | 43. sfx:GorgeousCrzy | 86. kit:MS20          |
| 1. bas:Big FM Bass   | 44. sfx:Nepatunism   | 87. kit:MS20 #2       |
| 2. bas:Bottom 101    | 45. sfx:The Dead See | 88. kit:SK-1          |
| 3. bas:Warm SEM      | 46. sfx:Hold Up      | 89. kit:SP1200        |
| 4. bas:Arpy Bass     | 47. sfx:The Garden   | 90. kit:Electronic 1  |
| 5. bas:Mini Snap 2   | 48. sfx:Acid Rain    | 91. kit:Electronic 2  |
| 6. bas:Arp Snap      | 49. sfx:NoZ          | 92. kit:Electronic 3  |
| 7. bas:BigSnap       | 50. arp:Loopy Gruv   | 93. kit:Electronic 4  |
| 8. bas:FatFingers    | 51. arp:Drifter      | 94. kit:Electronic 5  |
| 9. bas:Deep End 1    | 52. arp:Classic      | 95. kit:HighBoy       |
| 10. bas:Deep End 2   | 53. arp:Downtown     | 96. kit:Double Kit    |
| 11. bas:Wide & Deep  | 54. arp:Khord        | 97. kit:VintagePhase  |
| 12. bas:ThiklySettld | 55. arp:Tracker      | 98. kit:Flashback     |
| 13. bas:VintSynBass1 | 56. arp:MinorHorns   | 99. kit:Stadium       |
| 14. bas:MurkySweep   | 57. arp:Sparkle      | 100. kit:Soft Fuzz    |
| 15. bas:LayerBass    | 58. arp:DrumPitchy   | 101. kit:NickleMix    |
| 16. bas:Expressive   | 59. arp:SquareThump  | 102. kit:Soul Power   |
| 17. bas:Taurnado     | 60. arp:MinorFinale  | 103. kit:Beef Cake    |
| 18. bas:Picote       | 61. arp:HiPassCmputr | 104. kit:BrightMoment |
| 19. bas:Finger       | 62. arp:EMU 2 Live!  | 105. kit:Lil Popper   |
| 20. bas:Pilot        | 63. arp:BowCircuit   | 106. kit:InTheAir     |
| 21. bas:Hummer       | 64. arp:HardRepeat   | 107. kit:B Boy        |
| 22. bas:Bagg         | 65. arp:Tribal Toms  | 108. prc:All Kicks    |
| 23. bas:TS Mini      | 66. arp:DrumRoller   | 109. prc:All Snares   |
| 24. bas:MonoMe       | 67. arp:ZipTripper   | 110. prc:All Toms     |
| 25. bas:MonoMe2      | 68. arp:Log Funk     | 111. prc:All Hats     |
| 26. bas:Bounce       | 69. bts:FastRock     | 112. prc:All Cymbals  |
| 27. bas:303 Saws     | 70. bts:RockFunk     | 113. prc:Shakers      |
| 28. bas:303 Squares  | 71. bts:Shuffle      | 114. prc:Snaps        |
| 29. bas:Phatt Taurus | 72. bts:Chill Room   | 115. prc:Congas       |
| 30. bas:So Lo Pro    | 73. bts:Teardrop     | 116. prc:Misc         |
| 31. gtr:Hackettism   | 74. bts:Evolution    | 117. prc:Few ChoreMen |
| 32. gtr:Spy vs Spy   | 75. bts:The Pulse    | 118. prc:Steeely 1    |
| 33. gtr:AirGuitar    | 76. bts:Dreamland    | 119. prc:Steeely 2    |
| 34. gtr:Hit It       | 77. bts:Fusion       | 120. prc:Arnold 1     |
| 35. gtr:Wacka 1      | 78. bts:Jazz         | 121. prc:8bit Blocks  |
| 36. gtr:Wacka 2      | 79. bts:DropBeatBglu | 122. prc:Air Strike   |
| 37. gtr:Jazzy        | 80. kit:Acoustic GM  | 123. bts:Reggae       |
| 38. gtr:Clav Guitar  | 81. kit:Acoustic 2   | 124. prc:A Sine       |
| 39. gtr:HarmonicTone | 82. kit:El GM Kit 1  | 125. bts:NeoLatinRock |
| 40. sfx:Evil Saws    | 83. kit:El GM Kit 2  | 126. bts:NuRocker     |
| 41. sfx:DragonBreath | 84. kit:808          | 127. :Default v1.0    |
| 42. sfx:SpaceMuffin  | 85. kit:909          |                       |

## Instrument Listing

This section lists the raw instruments in the Vintage Pro ROM set. The instruments are either multisamples or single samples.

|                      |                      |                        |
|----------------------|----------------------|------------------------|
| 0. :None             | 42. syn:Classic Mini | 84. gtr:Happy Strum    |
| 1. epo:Dyno EP 1     | 43. syn:Mini Saws    | 85. gtr:Wacka 1        |
| 2. epo:Dyno EP 2     | 44. syn:JP8Brass     | 86. gtr:Wacka 2        |
| 3. epo:Dyno EP 3     | 45. syn:SuperJuno    | 87. str:Tron Strings   |
| 4. epo:Dyno EP 4     | 46. syn:Big JX       | 88. str:M12 Strings    |
| 5. epo:Dyno Low      | 47. syn:Angry Juno   | 89. str:Solina         |
| 6. epo:Dyno Med      | 48. syn:P10 Big      | 90. str:Elka Cello     |
| 7. epo:Dyno Hd/Med   | 49. syn:P10 Fat Saw  | 91. str:Elka String    |
| 8. epo:Dyno Lw/Hd    | 50. syn:P5 Sync      | 92. str:Elka Combo     |
| 9. epo:Dyno Hard     | 51. syn:P5 UniSync   | 93. str:Synth String   |
| 10. epo:Mello EP     | 52. syn:P5 Uni Saw   | 94. vox:Tron Males     |
| 11. epo:Mello EP Low | 53. syn:P5 Piper     | 95. vox:Tron Females   |
| 12. epo:Mello EP Hd  | 54. syn:M12 Lead     | 96. vox:Tron Mix       |
| 13. epo:Wurly EP     | 55. syn:ARP SyncMod  | 97. vox:P10 Choir      |
| 14. epo:Wurly Soft   | 56. syn:ArpPlsRsmpl  | 98. vox:Flight Aahs    |
| 15. epo:Wurly Medium | 57. syn:Arp Saw      | 99. brs:Tron Brass     |
| 16. epo:Wurly Hard   | 58. syn:Arp Square   | 100. wnd:Tron Flute    |
| 17. epo:CP70         | 59. syn:Sync Wah     | 101. wav:MiniTriangle  |
| 18. epo:CP70 Medium  | 60. syn:101VariPulse | 102. wav:Mini Saw      |
| 19. epo:CP70 Hard    | 61. syn:E-mu Modular | 103. wav:Mini Square   |
| 20. epo:FM EP        | 62. bas:Fat Taurus   | 104. wav:Mini Pulse 1  |
| 21. org:1st3 Slow    | 63. bas:Taurus Osc.  | 105. wav:Mini Pulse 2  |
| 22. org:1st3 Fast    | 64. bas:SEM QBass 1  | 106. wav:JX Square     |
| 23. org:1st4 Slow vb | 65. bas:SEM QBass 2  | 107. wav:JX Saw        |
| 24. org:AllOutSlwDst | 66. bas:SEM QBass 3  | 108. wav:JX Pulse      |
| 25. org:AllOutFstDst | 67. bas:SEMSyncBs 1  | 109. wav:Juno Square   |
| 26. org:Perc 2nd     | 68. bas:SEMSyncBs 2  | 110. wav:Juno Saw      |
| 27. org:Perc 3rd     | 69. bas:MiniSnapBass | 111. wav:Juno Pulse    |
| 28. org:Farfisa      | 70. bas:M WarmSquare | 112. wav:P10 Saw       |
| 29. org:Vox Jaguar   | 71. bas:PPG Bass     | 113. wav:P10 Triangle  |
| 30. key:Clavinet 1   | 72. bas:PPG DigiBass | 114. wav:P10 Pulse     |
| 31. key:Clavinet 2   | 73. bas:P5 Bass      | 115. wav:P10Inharmonic |
| 32. syn:OB WideBrass | 74. bas:ArpFatBass   | 116. wav:JX            |
| 33. syn:OBX PWM      | 75. bas:DX EP Bass 1 | 117. wav:101 Square    |
| 34. syn:OB Saw PWM   | 76. bas:DX EP Bass 2 | 118. wav:101 Saw       |
| 35. syn:OB PulseSync | 77. bas:FM Bass      | 119. wav:Sine          |
| 36. key:OB Clav      | 78. bas:FM Polybass  | 120. wav:Sine Squared  |
| 37. epo:OB EP        | 79. bas:Synth Hummer | 121. wav:Sine InvSqr   |
| 38. syn:SEM Fuzz     | 80. bas:Pilot        | 122. wav:Sine Cubed    |
| 39. syn:SEM Saws     | 81. bas:Bagg         | 123. wav:SineInvCubed  |
| 40. syn:Rogue Saws   | 82. bas:Finger       | 124. wav:Aluminum      |
| 41. syn:Rogue Sqr    | 83. gtr:Electric     | 125. nse:Spectrum 1    |

*Instrument Listing*

- |      |                  |      |              |      |              |
|------|------------------|------|--------------|------|--------------|
| 127. | nse:Spectrum 2   | 171. | prc:Misc     | 215. | prc:Snare 19 |
| 128. | nse:Spectrum 3   | 172. | prc:Kick 1   | 216. | prc:Snare 20 |
| 129. | nse:Spectrum 4   | 173. | prc:Kick 2   | 217. | prc:Snare 21 |
| 130. | nse:Hi Pass      | 174. | prc:Kick 3   | 218. | prc:Snare 22 |
| 131. | nse:Xcite HiPass | 175. | prc:Kick 4   | 219. | prc:Snare 23 |
| 132. | nse:White Noise  | 176. | prc:Kick 5   | 220. | prc:Snare 24 |
| 133. | nse:Pink Noise   | 177. | prc:Kick 6   | 221. | prc:Snare 25 |
| 134. | nse:101 Noise    | 178. | prc:Kick 7   | 222. | prc:Snare 26 |
| 135. | sfx:Whine        | 179. | prc:Kick 8   | 223. | prc:Snare 27 |
| 136. | sfx:Clav Tick    | 180. | prc:Kick 9   | 224. | prc:Snare 28 |
| 137. | sfx:Tack Attack  | 181. | prc:Kick 10  | 225. | prc:Snare 29 |
| 138. | sfx:Bad Synth    | 182. | prc:Kick 11  | 226. | prc:Snare 30 |
| 139. | sfx:Cluster Vox  | 183. | prc:Kick 12  | 227. | prc:Snare 31 |
| 140. | sfx:Kluster Loop | 184. | prc:Kick 13  | 228. | prc:Snare 32 |
| 141. | kit:Electro GM 1 | 185. | prc:Kick 14  | 229. | prc:Snare 33 |
| 142. | kit:Electro GM 2 | 186. | prc:Kick 15  | 230. | prc:Snare 34 |
| 143. | kit:808          | 187. | prc:Kick 16  | 231. | prc:Snare 35 |
| 144. | kit:909          | 188. | prc:Kick 17  | 232. | prc:Tom 1    |
| 145. | kit:MS20         | 189. | prc:Kick 18  | 233. | prc:Tom 2    |
| 146. | kit:MS20 #2      | 190. | prc:Kick 19  | 234. | prc:Tom 3    |
| 147. | kit:SK-1         | 191. | prc:Kick 20  | 235. | prc:Tom 4    |
| 148. | kit:SP1200       | 192. | prc:Kick 21  | 236. | prc:Tom 5    |
| 149. | kit:Electronic 1 | 193. | prc:Kick 22  | 237. | prc:Tom 6    |
| 150. | kit:Electronic 2 | 194. | prc:Kick 23  | 238. | prc:Tom 7    |
| 151. | kit:Electronic 3 | 195. | prc:Kick 24  | 239. | prc:Tom 8    |
| 152. | kit:Electronic 4 | 196. | prc:Kick 25  | 240. | prc:Tom 9    |
| 153. | kit:Electronic 5 | 197. | prc:Snare 1  | 241. | prc:Tom 10   |
| 154. | kit:Electronic 6 | 198. | prc:Snare 2  | 242. | prc:Tom 11   |
| 155. | kit:Electronic 7 | 199. | prc:Snare 3  | 243. | prc:Tom 12   |
| 156. | kit:Electronic 8 | 200. | prc:Snare 4  | 244. | prc:Tom 13   |
| 157. | kit:Acoustic GM  | 201. | prc:Snare 5  | 245. | prc:Tom 14   |
| 158. | kit:Acoustic 2   | 202. | prc:Snare 6  | 246. | prc:Tom 15   |
| 159. | kit:Acoustic 3   | 203. | prc:Snare 7  | 247. | prc:Tom 16   |
| 160. | kit:Acoustic 4   | 204. | prc:Snare 8  | 248. | prc:Tom 17   |
| 161. | kit:Jazz Brush   | 205. | prc:Snare 9  | 249. | prc:Hat 1    |
| 162. | kit:Hybrid       | 206. | prc:Snare 10 | 250. | prc:Hat 2    |
| 163. | prc:All Kicks    | 207. | prc:Snare 11 | 251. | prc:Hat 3    |
| 164. | prc:All Snares   | 208. | prc:Snare 12 | 252. | prc:Hat 4    |
| 165. | prc:All Toms     | 209. | prc:Snare 13 | 253. | prc:Hat 5    |
| 166. | prc:All Hats     | 210. | prc:Snare 14 | 254. | prc:Hat 6    |
| 167. | prc:All Cymbals  | 211. | prc:Snare 15 | 255. | prc:Hat 7    |
| 168. | prc:Shakers etc  | 212. | prc:Snare 16 | 256. | prc:Hat 8    |
| 169. | prc:Snaps etc    | 213. | prc:Snare 17 | 257. | prc:Hat 9    |
| 170. | prc:Congas etc   | 214. | prc:Snare 18 | 258. | prc:Hat 10   |



## Instrument Listing



*The Percussion  
Instruments on this page are  
single sample instruments  
stretched across the entire  
keyboard.*

|      |                |      |               |      |               |
|------|----------------|------|---------------|------|---------------|
| 259. | prc:Hat 11     | 304. | prc:Whistle   | 349. | prc:Conga 12  |
| 260. | prc:Hat 12     | 305. | prc:Shaker 1  | 350. | prc:Conga 13  |
| 261. | prc:Hat 13     | 306. | prc:Shaker 2  | 351. | prc:Conga 14  |
| 262. | prc:Hat 14     | 307. | prc:Shaker 3  | 352. | prc:Conga 15  |
| 263. | prc:Hat 15     | 308. | prc:Shaker 4  | 353. | prc:Misc 1    |
| 264. | prc:Hat 16     | 309. | prc:Shaker 5  | 354. | prc:Misc 2    |
| 265. | prc:Hat 17     | 310. | prc:Shaker 6  | 355. | prc:Misc 3    |
| 266. | prc:Hat 18     | 311. | prc:Shaker 7  | 356. | prc:Misc 4    |
| 267. | prc:Hat 19     | 312. | prc:Shaker 8  | 357. | prc:Misc 5    |
| 268. | prc:Hat 20     | 313. | prc:Shaker 9  | 358. | prc:Misc 6    |
| 269. | prc:Hat 21     | 314. | prc:Shaker 10 | 359. | prc:Misc 7    |
| 270. | prc:Hat 22     | 315. | prc:Shaker 11 | 360. | prc:Misc 8    |
| 271. | prc:Hat 23     | 316. | prc:Shaker 12 | 361. | prc:Misc 9    |
| 272. | prc:Hat 24     | 317. | prc:Shaker 13 | 362. | prc:Misc 10   |
| 273. | prc:Hat 25     | 318. | prc:Shaker 14 | 363. | prc:Misc 11   |
| 274. | prc:Hat 26     | 319. | prc:Shaker 15 | 364. | prc:Misc 12   |
| 275. | prc:Hat 27     | 320. | prc:Shaker 16 | 365. | prc:Misc 13   |
| 276. | prc:Cymbal 1   | 321. | prc:Shaker 17 | 366. | prc:Misc 14   |
| 277. | prc:Cymbal 2   | 322. | prc:Shaker 18 | 367. | prc:Misc 15   |
| 278. | prc:Cymbal 3   | 323. | prc:Shaker 19 | 368. | prc:Misc 16   |
| 279. | prc:Cymbal 4   | 324. | prc:Shaker 20 | 369. | prc:Misc 17   |
| 280. | prc:Cymbal 5   | 325. | prc:Shaker 21 | 370. | prc:Misc 18   |
| 281. | prc:Cymbal 6   | 326. | prc:Shaker 22 | 371. | prc:Misc 19   |
| 282. | prc:Cymbal 7   | 327. | prc:Shaker 23 | 372. | prc:Misc 20   |
| 283. | prc:Cymbal 8   | 328. | prc:Shaker 24 | 373. | prc:Misc 21   |
| 284. | prc:Cymbal 9   | 329. | prc:Shaker 25 | 374. | prc:Misc 22   |
| 285. | prc:Cymbal 10  | 330. | prc:Clap 1    | 375. | prc:Misc 23   |
| 286. | prc:Cymbal 11  | 331. | prc:Clap 2    | 376. | prc:Big Hit 1 |
| 287. | prc:Cymbal 12  | 332. | prc:Clap 3    | 377. | prc:Big Hit 2 |
| 288. | prc:Cymbal 13  | 333. | prc:Clap 4    | 378. | prc:Scratch 1 |
| 289. | prc:Cymbal 14  | 334. | prc:Clap 5    | 379. | prc:Scratch 2 |
| 290. | prc:Cymbal 15  | 335. | prc:Clap 6    | 380. | sfx:Wakka 1   |
| 291. | prc:Cymbal 16  | 336. | prc:Clap 7    | 381. | sfx:Wakka 2   |
| 292. | prc:Vibraslap  | 337. | prc:Snap      | 382. | sfx:Wakka 3   |
| 293. | prc:Clave 1    | 338. | prc:Conga 1   | 383. | sfx:Wakka 4   |
| 294. | prc:Clave 2    | 339. | prc:Conga 2   | 384. | sfx:Wakka 5   |
| 295. | prc:Clave 3    | 340. | prc:Conga 3   | 385. | sfx:Wakka 6   |
| 296. | prc:Cowbell 1  | 341. | prc:Conga 4   | 386. | sfx:Wakka 7   |
| 297. | prc:Cowbell 2  | 342. | prc:Conga 5   | 387. | sfx:Wakka 8   |
| 298. | prc:Cowbell 3  | 343. | prc:Conga 6   | 388. | sfx:Wakka 9   |
| 299. | prc:Cowbell 4  | 344. | prc:Conga 7   | 389. | sfx:Wakka 10  |
| 300. | prc:Tamb 1     | 345. | prc:Conga 8   | 390. | sfx:Wakka 11  |
| 301. | prc:Tamb 2     | 346. | prc:Conga 9   | 391. | sfx:Wakka 12  |
| 302. | prc:Triangle 1 | 347. | prc:Conga 10  | 392. | sfx:Wakka 13  |
| 303. | prc:Triangle 2 | 348. | prc:Conga 11  | 393. | sfx:Wakka Map |

*Instrument Listing*

- |                        |                         |                              |
|------------------------|-------------------------|------------------------------|
| <b>395.</b> sfx:Tick 1 | <b>401.</b> sfx:Tick 7  | <b>407.</b> sfx:Tick 13      |
| <b>396.</b> sfx:Tick 2 | <b>402.</b> sfx:Tick 8  | <b>408.</b> bas:Bright Saw   |
| <b>397.</b> sfx:Tick 3 | <b>403.</b> sfx:Tick 9  | <b>409.</b> bas:BrightResSaw |
| <b>398.</b> sfx:Tick 4 | <b>404.</b> sfx:Tick 10 | <b>410.</b> bas:BrightSquare |
| <b>399.</b> sfx:Tick 5 | <b>405.</b> sfx:Tick 11 | <b>411.</b> bas:Res Square   |
| <b>400.</b> sfx:Tick 6 | <b>406.</b> sfx:Tick 12 |                              |

## Riff Listing

- |                       |                      |                       |
|-----------------------|----------------------|-----------------------|
| 1. AmUD-C1 (4 bars)   | 45. BRS-FullTrnBrass | 89. EPO-Wurlilayer2   |
| 2. AUD-C3 (1 bar)     | 46. BRS-Thick Brass  | 90. EPO-Wurly         |
| 3. AUD-C3 (2 Bars)    | 47. BRS-ThickBrass   | 91. EPO-Wurly 2       |
| 4. AUD-C3 (4 Bars)    | 48. BRS-Windy Brass  | 92. GTR-Hackettism    |
| 5. AUD-C4             | 49. CMB-B3EP         | 93. GTR-Hackettism2   |
| 6. AUD-C Triad        | 50. CMB-PulseMadness | 94. GTR-Hit It        |
| 7. AUD-Cm7            | 51. CMB-Rogue Mini   | 95. GTR-Jazzy         |
| 8. AUD-Cm9            | 52. CMB-Taurus&Strng | 96. GTR-Spy vs Spy    |
| 9. AUD-Cmaj7          | 53. CMB-Flute&String | 97. GTR-SpyvsSpy2     |
| 10. AUD-Cs Up         | 54. EPO-Analog FM    | 98. GTR-Wacka         |
| 11. AUD-Cs Up-Down    | 55. EPO-ChorusDyn2   | 99. KEY-Buzzy Clav    |
| 12. ARP-Classic       | 56. EPO-ChorusDyno   | 100. KEY-Clav 1       |
| 13. ARP-Downtown      | 57. EPO-Classic CP   | 101. KEY-Clav2        |
| 14. BAS-Arp Snap      | 58. EPO-CP Layer     | 102. KEY-Clav1&2      |
| 15. BAS-Arpy Bass     | 59. EPO-CP Layer2    | 103. KEY-Clav2 Phase  |
| 16. BAS-Arpy Bass2    | 60. EPO-CP70         | 104. KEY-Funk Master  |
| 17. BAS-Bagg          | 61. EPO-CP70 2       | 105. KEY-FunkMaster   |
| 18. BAS-Bagg 2        | 62. EPO-Dyno         | 106. KEY-PhaseClav1   |
| 19. BAS-Big FM Bass   | 63. EPO-Dyno 2       | 107. KEY-StereoClav 1 |
| 20. BAS-Big Taurus    | 64. EPO-DynoChorus   | 108. KEY-Synth Clav   |
| 21. BAS-Big Taurus2   | 65. EPO-DynoOdd      | 109. KEY-TwoClavs     |
| 22. BAS-BigSnap       | 66. EPO-DynoSft1     | 110. LED-BeginAgain   |
| 23. BAS-BigSnap2      | 67. EPO-DynoStcase   | 111. LED-Frank Stein  |
| 24. BAS-Bottom 101    | 68. EPO-Fm Flanger   | 112. LED-JunoOvrDrive |
| 25. BAS-Bottom 101 2  | 69. EPO-FM Phase 1   | 113. LED-M12          |
| 26. BAS-Deep End 1    | 70. EPO-FM Phase 2   | 114. LED-Mean Wheel   |
| 27. BAS-Deep End 2    | 71. EPO-FMDelicate   | 115. LED-OverDrive101 |
| 28. BAS-Expressive    | 72. EPO-Heavy Dyno   | 116. LED-PortaLead    |
| 29. BAS-Finger        | 73. EPO-MarshMello   | 117. LED-Power Mini   |
| 30. BAS-Hummer        | 74. EPO-LiteDyno     | 118. LED-Pulse        |
| 31. BAS-Hummer 2      | 75. EPO-Lullaby      | 119. LED-Pulse 2      |
| 32. BAS-Mini Snap     | 76. EPO-Mama'sWurli  | 120. LED-Soft&Round   |
| 33. BAS-Mini Snap 2   | 77. EPO-Mello EP1    | 121. LED-WickedSquare |
| 34. BAS-MurkySweep    | 78. EPO-Mello EP2    | 122. ORG-1st3 2       |
| 35. BAS-Picote        | 79. EPO-Mellow Pop   | 123. ORG-1st3 2ndPerc |
| 36. BAS-Picote2       | 80. EPO-MetalBars    | 124. ORG-1st3 3rdPerc |
| 37. BAS-Pilot         | 81. EPO-OB EP        | 125. ORG-1st3FullDist |
| 38. BAS-Taurnado      | 82. EPO-OB EP 2      | 126. ORG-1st4 Vibrato |
| 39. BAS-TaurusPedals  | 83. EPO-OB Tine EP   | 127. ORG-All Out      |
| 40. BAS-ThiklySettled | 84. EPO-Real CP      | 128. ORG-B3 Rock1     |
| 41. BAS-TS Mini       | 85. EPO-Studio EP    | 129. ORG-B3 Rock2     |
| 42. BRS-Big Swell 2   | 86. EPO-The CP70     | 130. ORG-Distortion   |
| 43. BRS-E2 Brass      | 87. EPO-Vintage CP   | 131. ORG-Distortion 2 |
| 44. BRS-E2 Brass2     | 88. EPO-Wurlilayer   | 132. ORG-Far Away     |

Riff Listing

- |                       |                       |                        |
|-----------------------|-----------------------|------------------------|
| 133. ORG-MelloCombo   | 177. SYN-Nephilim     | 221. KIT-Kit 03        |
| 134. ORG-PortaVib     | 178. SYN-NoteOffChime | 222. KIT-Kit 04        |
| 135. ORG-PortaVib 2   | 179. SYN-NoteOffChme2 | 223. KIT-Kit 05        |
| 136. PAD-Annunaki     | 180. SYN-Nunzio 1     | 224. KIT-Kit 06        |
| 137. PAD-Believe      | 181. SYN-Nunzio 2     | 225. KIT-Kit 07        |
| 138. PAD-Chiffer      | 182. SYN-Nunzio 3     | 226. KIT-Kit 08        |
| 139. PAD-Lunadef      | 183. SYN-OB Glider    | 227. KIT-Kit 09        |
| 140. PAD-Lunadef 2    | 184. SYN-OBSEMFuzz    | 228. KIT-Kit 10        |
| 141. PAD-Lunadef 3    | 185. SYN-ProphetPiano | 229. KIT-Kit 11        |
| 142. PAD-Lunadef 4    | 186. SYN-P Ten        | 230. KIT-MS20          |
| 143. PAD-Matches      | 187. SYN-P10          | 231. KIT-SK-1          |
| 144. PAD-ProfitMargin | 188. SYN-P10 SkySweep | 232. KIT-SK-1 2        |
| 145. PAD-QuietSaws    | 189. SYN-P5 PolySync  | 233. KIT-Soft Fuzz     |
| 146. PAD-Sentinels    | 190. SYN-Merlot       | 234. KIT-SP1200        |
| 147. PAD-Thin Lad     | 191. SYN-Phase1Alert  | 235. BTS-Acoustic      |
| 148. PRC-Arnold 1     | 192. SYN-PortaLead    | 236. BTS-Acoustic 4    |
| 149. PRC-Few ChoreMen | 193. SYN-Power Juno   | 237. BTS-Brick         |
| 150. PRC-Steely       | 194. SYN-Random OB    | 238. BTS-Chill Room    |
| 151. PRC-Steely 1     | 195. SYN-Regbit       | 239. BTS-Clav          |
| 152. SFX-DragonBreath | 196. SYN-Rogue        | 240. BTS-CPStage       |
| 153. SFX-EvilSaws     | 197. SYN-Round Mini   | 241. BTS-Dreamland     |
| 154. STR-Analog Harp  | 198. SYN-Runner       | 242. BTS-Dropbeat      |
| 155. STR-Big M12      | 199. SYN-SawsofOld    | 243. BTS-DropBeatBglu  |
| 156. STR-Elka Combo   | 200. SYN-Syrupy       | 244. BTS-DX Style      |
| 157. STR-Lush70'sFade | 201. SYN-TouchRez     | 245. BTS-Evolution     |
| 158. STR-Lush70sFade2 | 202. SYN-Wall O Saws  | 246. BTS-Fast Rocker   |
| 159. STR-Sepiatone    | 203. SYN-Wide OB      | 247. BTS-Fast Rocker 2 |
| 160. STR-Sepiatone2   | 204. SYN-Wide OB 2    | 248. BTS-Fusion        |
| 161. STR-Smooth&Wide  | 205. VOX-BigTronChoir | 249. BTS-Jazz          |
| 162. STR-Solina       | 206. VOX-Light Aahs   | 250. BTS-Lush          |
| 163. STR-String Box   | 207. VOX-Light Aahs 2 | 251. BTS-NeoLatinRock  |
| 164. STR-VeloBows     | 208. VOX-Light Aahs 3 | 252. BTS-NuRocker      |
| 165. SYN-10101        | 209. WND-LoFi Flute   | 253. BTS-Reggae        |
| 166. SYN-80zFuzzPad   | 210. WND-StereoMtron  | 254. BTS-Rock          |
| 167. SYN-80zFuzzPad2  | 211. WND-Tron Flute   | 255. BTS-Rock 2        |
| 168. SYN-Big Mini     | 212. WND-Tron Flute2  | 256. BTS-Shuffle       |
| 169. SYN-El Effo Sr   | 213. KIT-Acoustic 2   | 257. BTS-Teardrop      |
| 170. SYN-FuzzBell     | 214. KIT-DoubleKit    | 258. BTS-The Pulse     |
| 171. SYN-Huge SEM     | 215. KIT-El GM Kit 1  | 259. BTS-Latin         |
| 172. SYN-Juno         | 216. KIT-Electronic 3 | 260. BTS-Funkersize    |
| 173. SYN-Juno Pulse   | 217. KIT-Flashback    |                        |
| 174. SYN-Late 80z     | 218. KIT-HighBoy      |                        |
| 175. SYN-Monster Clav | 219. KIT-Kit 01       |                        |
| 176. SYN-Morpheus     | 220. KIT-Kit 02       |                        |

# Velocity Curves

This section provides diagrams and descriptions of the Vintage Pro velocity curves.

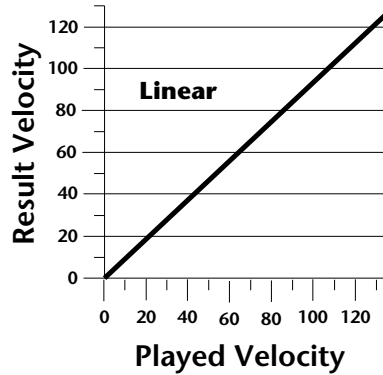

Linear, no change to velocity.

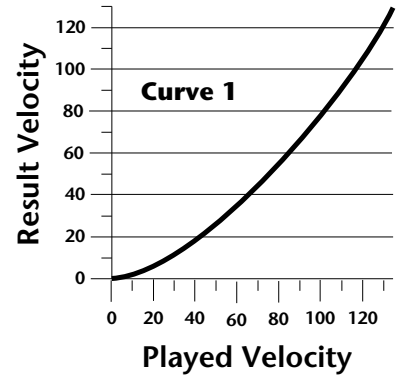

Compresses velocity range.

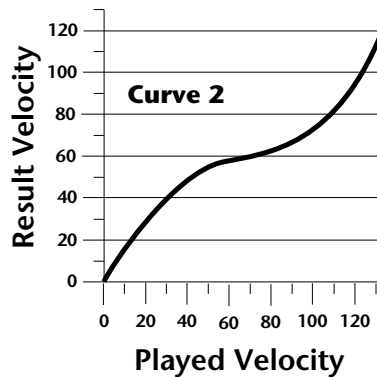

Expands dynamics in low range, emphasizing medium velocity values and compressing high velocity values.

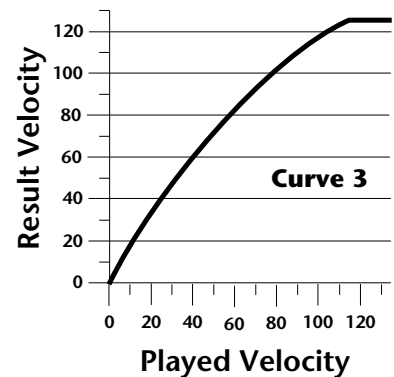

Expands velocity range.  
Soft -> Loud

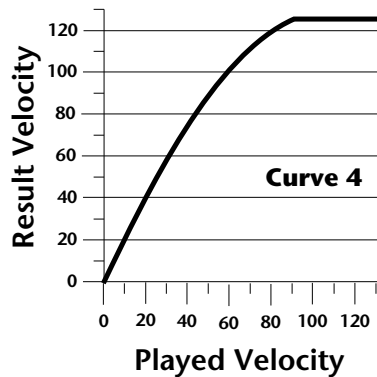

Expands velocity range.  
Outputs high values.

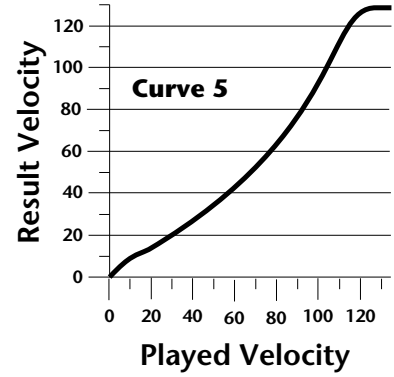

Shifts velocity values upward.  
Good dynamic range.

Velocity Curves

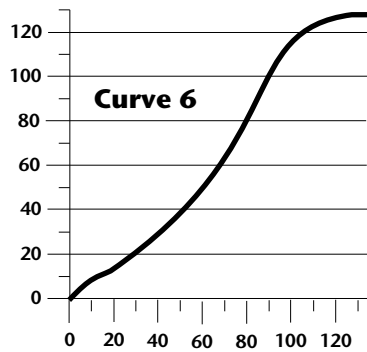

**Played Velocity**

Shifts velocity values up while compressing the middle range.

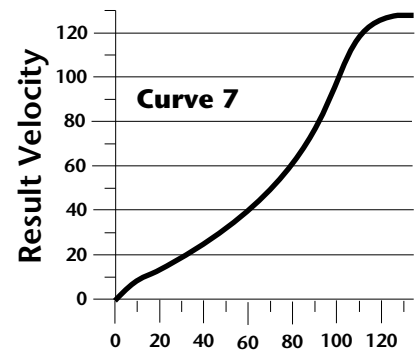

**Played Velocity**

Similar to Curve 6.

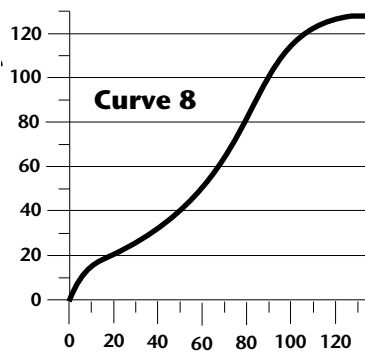

**Played Velocity**

Similar to Curve 6 with more emphasis on the middle range.

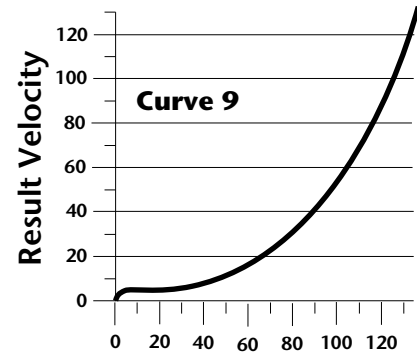

**Played Velocity**

Extreme dynamic range compression.

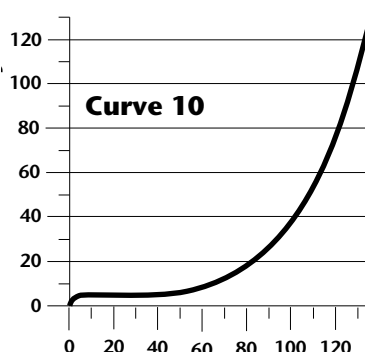

**Played Velocity**

Extreme dynamic range compression. Outputs low values.

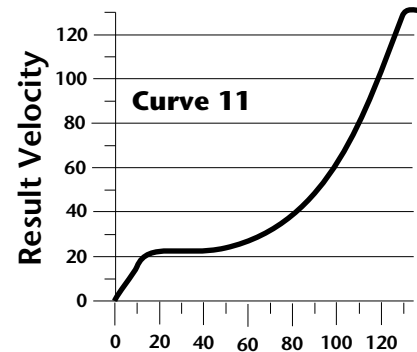

**Played Velocity**

Extreme dynamic range compression but doesn't output low values

## PatchCord Amount Chart

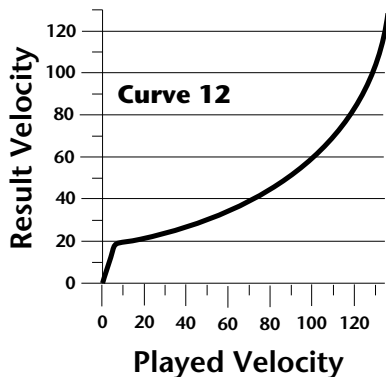

Less severe version of Curve 11.

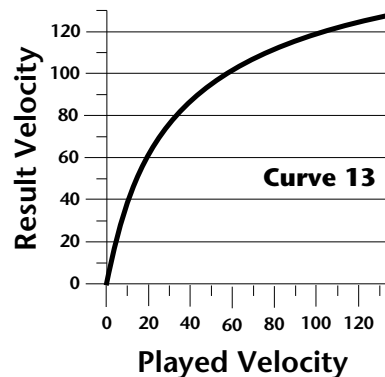

Extreme expansion of velocity range.

The following chart shows the PatchCord “Amount” settings in order to get semitone intervals when modulation sources are connected to pitch.

| Semitone | PatchCord Amount | Semitone | PatchCord Amount |
|----------|------------------|----------|------------------|
| 1        | 3                | 21       | 66               |
| 2        | 6                | 22       | 69               |
| 3        | approx. 9        | 23       | approx. 72.5     |
| 4        | approx. 12       | 24       | approx. 76       |
| 5        | 16               | 25       | 79               |
| 6        | 19               | 26       | 82               |
| 7        | 22               | 27       | 88               |
| 8        | 25               | 28       | 91               |
| 9        | 28               | 29       | approx. 95       |
| 10       | approx. 31       | 30       | 98               |
| 11       | 35               | 31       |                  |
| 12       | 38               | 32       |                  |
| 13       | 41               | 33       |                  |
| 14       | 44               | 34       |                  |
| 15       | 47               | 35       |                  |
| 16       | 50               | 36       |                  |
| 17       | approx. 53       | 37       |                  |
| 18       | 57               | 38       |                  |
| 19       | 60               | 39       |                  |
| 20       | 63               | 40       |                  |

# E-MU Expansion Sound Sets



Eleven different ROM expansions are currently available, with more being developed every day. ROM expansions typically add 32MB of sound data and 512 additional presets. Adding new sounds is like getting a new instrument and a sure way to spark your creativity. ROM Expansions are available from your E-MU dealer. Also check out the official E-MU website: [www.emu.com](http://www.emu.com) for the latest sounds.

## Orchestral Sessions VOLUME 1

The Orchestral Sessions Vol. 1 expansion 32 MB ROM offers you the most realistic and comprehensive collection of section strings available, complete with legato, spiccato, pizzicato and tremolande samples, and includes special presets for 4 speaker applications.

## Orchestral Sessions VOLUME 2

The Orchestral Sessions Vol. 2 expansion 32 MB ROM offers you the most realistic and comprehensive collection of woodwinds, brass, percussion, and solo strings available, complete with velocity switching between p/mf/ff samples, special presets for 4 speaker applications and a percussion battery with over 20 instruments.

## Siedlaczek Orchestra Special Edition

The Peter Siedlaczek Advanced Orchestra Special Edition puts 32 MB of his finest ensembles onto a single expansion ROM for your Vintage Pro. String, brass, woodwind and percussion ensembles are included in a variety of styles (i.e. vibrato, tremolo, pizzicato, sordino, etc.), to give you a diverse collection of samples.

## Protozoa

E-MU presents the 16 MB Protozoa expansion ROM—the ultimate sound compilation containing presets from the ground breaking Proteus sound modules, all optimized for the Vintage Pro's advanced synthesis and filter architecture.

## Sounds of the ZR

The Sounds of the ZR Expansion ROM faithfully reproduces the diverse sounds of ENSONIQ's popular ZR-76 keyboard, including William Coakley's Perfect Piano. You'll find everything from synths and orchestral instruments to one of the finest pianos ever sampled in one sound set.

## Definitive B-3

John Novello and E-MU present the 32 MB Definitive B-3 expansion ROM, a diverse collection of tone wheel organ drawbar settings sampled direct and with rotary speakers (chorale and tremolo) to give you the most versatile and playable B-3 available!





### X-Lead

The X-Lead sound set consists primarily of analog, noise and modern synthesizer waveforms. These sounds are rich in harmonic texture and are a perfect match with the Z-plane filters in your Proteus® family sound module. With the included software upgrade, you now have access to dynamic and rhythmic features not found on any other instrument.



### PURE PHATT

The 32 MB Pure Phatt is E-MU's latest Hip-Hop sound set containing the freshest and newest sounds and grooves from top notch producers from the East, Southeast and West coasts. Pumping leads and basses, silky pads, unique hits, scratches and drones are ready to provide the love and bring your mix to the next level.



### World Expedition

An amazing collection of traditional instruments from the four corners of the globe including exotic stringed instruments, winds, percussion, and chromatic percussion. World Expedition provides you with the most realistic ethnic sound set in the world. Discover a world of sounds to bring to your music.



### Techno Synth

Rob Papen and E-MU introduce the 32 MB Techno Synth Construction Yard Expansion ROM, a compilation of synth, techno, and ambient sounds from one of Europe's finest programmers. From atmospheric pads to punchy sub-basses and crunch drum loops, these sounds will help you tear up the dance floor!



### Beat Garden

Dutch sound designer Rob Papen and E-MU introduce the 32 MB Beat Garden expansion ROM, a diverse palette of all-new Electronica/Dance beats, synths, basses, drum kits, acoustic and electronic percussion. Experience the Beat Garden for yourself and add a unique dimension to your tracks.



### Proteus Pop Collection

The 32 MB Proteus Pop Collection offers you all of the bread and butter sounds of E-MU's Proteus 2500 Module and PK-6 keyboard with 640 diverse presets covering everything from traditional keyboards and orchestral instruments to electric guitars, world percussion and drum kits.



### ENSONIQ Project

The 32 MB ENSONIQ Project Expansion ROM delivers the sounds of ENSONIQ's acclaimed Urban Dance Project and Real World collections with the Hip-Hop and World sounds heard on countless hits, all optimized for E-MU's powerful synthesis and filter architecture.

## Installing Sound SIMMs

Vintage Pro can be easily expanded to contain up to 128 MB of sound data (4 SIMMs).

**Make sure the unit is unplugged from the wall before doing anything!**

Before you begin, find a clean, well lit place in which to work. This procedure requires that you periodically “Ground” yourself, by touching a grounded object such as a water pipe or a grounded piece of equipment. Grounding yourself prevents the static charge in your body from damaging the sensitive memory chips. When you are asked to “Ground” yourself, simply reach over and touch the grounded metal. Do not walk across the room or a rug, as this will defeat the purpose of grounding.

### ► Remove the Top Cover

1. To gain access to the interior of the unit, the top panel must first be removed. The top panel is attached to the main chassis by means of (7) screws. There are three screws along the back of the unit and two on each side.
  - **If you have rack ears installed, these will have to be removed first.**
2. When all the screws are removed, slide the metal top backwards and up off the unit, exposing the main circuit board. Set the top cover aside in a safe place and put the screws into a cup so they will not get lost.
3. Ground yourself before touching anything inside the unit!

### ► Install the ROM SIMM

4. Ground yourself, then remove the ROM SIMM from the antistatic packaging.
5. To install a SIMM, refer to the diagram on the following page. The four Sound ROM SIMM sockets are located on the left side of the unit when viewed from the front.
6. In some cases, you may have to remove a SIMM in order to make room for another. When replacing SIMMs, replace the SIMM near the inner edge of the circuit board first. *See instructions below.*
7. Insert the SIMM module into an empty ROM socket, (*as shown in figure 1*) with the notch toward the rear of the unit. The SIMM should rest naturally in the socket.
8. Tilt the SIMM into a vertical position. Both tabs should lock.

### ► To Remove ROM SIMMs (if necessary):

9. On each end of the SIMM socket there is a silver or plastic tab. Use a screwdriver or a ball point pen to squeeze the tabs toward the outside of the socket while gently pushing the SIMM towards the right side of the unit (*when viewed from the rear*). The old SIMM should “hinge” down and can now be removed.

 ROMs can be placed in any available socket. This has no effect on the order of presets as shown in the display.

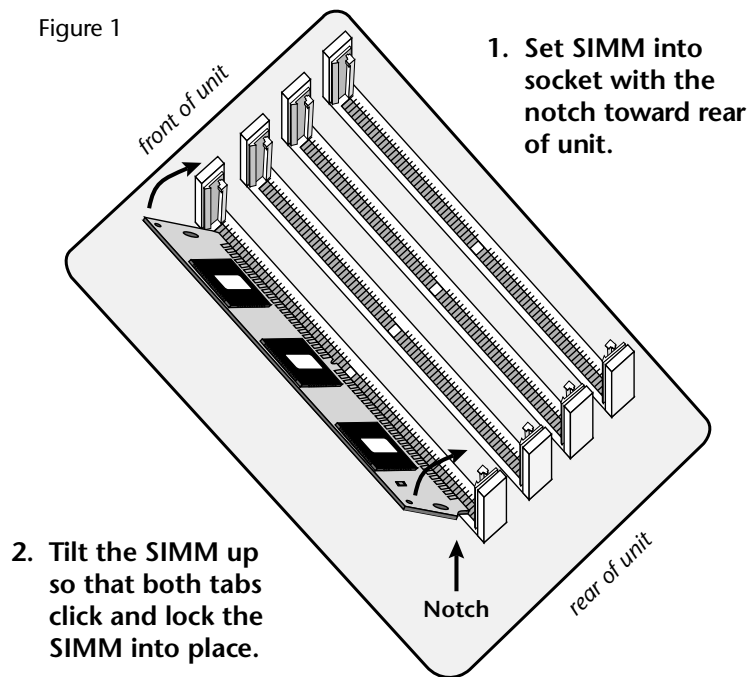

### ► Replace the Top Cover

10. Place the metal top cover on the box with the screw holes toward the rear.
  11. Lift the rear of the top cover and slide it forward UNDER the lip of the front panel bezel, then set the rear down. The screw holes should all be perfectly aligned.
  12. Replace the (7) screws.
  13. At this point, the installation is finished. Apply power and verify that your new ROM presets are listed in the main display.
- If the new ROM presets are NOT available in the display, disconnect power. Start from step 1 and re-seat the ROM in its socket. If it still doesn't work, call us. We're here to help.

### ► Problems?

1. Disconnect power immediately.
2. Open the unit, and try re-seating the ROM SIMMs. Take care that the RAM SIMMs are properly installed in the sockets. If you're still having problems, return the unit to its original configuration and call EMU Systems Customer Service at (831) 438-1921. Telephone support hours are 8:00-5:00 PST, Monday through Friday.

# MIDI

## MIDI Implementation Chart (part 1)

| MIDI Information                    | Transmitted  | Recognized   | Remarks                       |
|-------------------------------------|--------------|--------------|-------------------------------|
| MIDI Channels                       | 1-16 (A & B) | 1-16 (A & B) | 32 channels on two MIDI ports |
| Note Numbers                        | 0-127        | 0-127        |                               |
| Program Change                      | 0-127        | 0-127        |                               |
| Bank Select Response?               | No           | Yes          | MSB + LSB                     |
| Modes: Omni ( <i>Mode 1</i> )       | No           | Yes          |                               |
| Mono ( <i>Mode 2</i> )              | No           | Yes          |                               |
| Poly ( <i>Mode 3</i> )              | No           | Yes          |                               |
| Mode 4                              | No           | No           |                               |
| Multi ( <i>Mode 5</i> )             | No           | Yes          |                               |
| Note On Velocity                    | Yes          | Yes          |                               |
| Note Off Velocity                   | No           | Yes          |                               |
| Channel Aftertouch                  | Yes          | Yes          |                               |
| Poly (Key) Aftertouch               | No           | No           |                               |
| Pitch Bend                          | Yes          | Yes          |                               |
| Active Sensing                      | No           | No           |                               |
| System Reset                        | No           | No           |                               |
| Tune Request                        | No           | No           |                               |
| System Exclusive                    | Yes          | Yes          |                               |
| Sample Dump Standard                | No           | No           |                               |
| File Dump                           | Yes          | Yes          |                               |
| MIDI Tuning                         | Yes          | Yes          |                               |
| Master Volume                       | No           | Yes          |                               |
| Master Balance                      | No           | No           |                               |
| Notation Information                | No           | No           |                               |
| Turn GM1 System On                  | No           | No           |                               |
| Turn GM2 System On                  | No           | No           |                               |
| Turn GM1 System Off                 | No           | No           |                               |
| Other ( <i>See Remarks</i> )        | No           | No           |                               |
| NRPNS                               | No           | No           |                               |
| RPN 00 ( <i>Pitch Bend Sensi.</i> ) | No           | No           |                               |
| RPN 01 ( <i>Chan. Fine Tune</i> )   | No           | No           |                               |
| RPN 02 ( <i>Chan Coar. Tune</i> )   | No           | No           |                               |
| RPN 03 ( <i>Tuning Prog Sel.</i> )  | No           | No           |                               |
| RPN 04 ( <i>Tuning Bank Sel.</i> )  | No           | No           |                               |
| RPN 05 ( <i>Mod Depth Rang</i> )    | No           | No           |                               |
| <b>MIDI Timing &amp; Sync</b>       |              |              |                               |
| MIDI Clock                          | Yes          | Yes          |                               |
| Song Position Pointer               | No           | No           |                               |
| Song Select                         | No           | No           |                               |

MIDI

| MIDI Information            | Transmitted | Recognized | Remarks |
|-----------------------------|-------------|------------|---------|
| Start                       | No          | No         |         |
| Continue                    | No          | No         |         |
| Stop                        | No          | No         |         |
| MIDI Time Code              | No          | No         |         |
| MIDI Machine Control        | No          | No         |         |
| MIDI Show Control           | No          | No         |         |
| <b>Extension Capability</b> |             |            |         |
| General MIDI Compat?        | No          | No         |         |
| Is GM default mode?         | No          | No         |         |
| DLS compatible?             | No          | No         |         |
| Import DLS Files?           | No          | No         |         |
| Export DLS Files?           | No          | No         |         |
| Import Std MIDI files       | No          | No         |         |
| Export Std MIDI files       | No          | No         |         |
|                             |             |            |         |

MIDI

**MIDI Implementation Chart (part 2 - Controllers)**

| Control # | Function           | Transmitted | Recognized | Remarks      |
|-----------|--------------------|-------------|------------|--------------|
| 0         | Bank Select MSB    | Yes         | Yes        |              |
| 1         | Mod Wheel MSB      | Yes         | Yes        | * see note   |
| 2         | Breath Cntrl MSB   | No          | No         | * see note   |
| 3         |                    | No          | No         | *            |
| 4         | Foot Cntrl MSB     | Yes         | No         | *            |
| 5         | Portamento MSB     | No          | No         | *            |
| 6         | Data Entry MSB     | No          | No         | *            |
| 7         | Chan Volume MSB    | Yes         | Yes        | *            |
| 8         | Balance MSB        | No          | No         | *            |
| 9         |                    |             |            | *            |
| 10        | Pan MSB            | Yes         | Yes        | *            |
| 11        | Expression MSB     | No          | Yes        | *            |
| 12        | Effect Cntrl 1 MSB | No          | No         | *            |
| 13        | Effect Cntrl 2 MSB | No          | No         | *            |
| 14        |                    |             |            | *            |
| 15        |                    |             |            | *            |
| 16        | GenPur Ctrl 1 MSB  |             |            | *            |
| 17        | GenPur Ctrl 2 MSB  |             |            | *            |
| 18        | GenPur Ctrl 3 MSB  |             |            | *            |
| 19        | GenPur Ctrl 4 MSB  |             |            | *            |
| 20        |                    |             |            | *            |
| 21        |                    |             |            | *            |
| 22        |                    |             |            | *            |
| 23        |                    |             |            | *            |
| 24        |                    |             |            | *            |
| 25        | ➡                  | Yes         | Yes        | * Filt Attck |
| 26        | ➡                  | Yes         | Yes        | * Filt Decy  |
| 27        |                    |             |            | *            |
| 28        |                    |             |            | *            |
| 29        |                    |             |            | *            |
| 30        |                    |             |            | *            |
| 31        |                    |             |            | *            |
| 32        | Bank Select LSB    | Yes         | Yes        | *            |
| 33        | Mod Wheel LSB      |             |            | *            |
| 34        | Breath Cntrl LSB   |             |            | *            |
| 35        |                    |             |            | *            |
| 36        | Foot Cntrlr LSB    | No          | No         | *            |

MIDI

| Control # | Function           | Transmitted | Recognized | Remarks |
|-----------|--------------------|-------------|------------|---------|
| 37        | Portamento LSB     |             |            | *       |
| 38        | Data Entry LSB     |             |            | *       |
| 39        | Chan Volume LSB    |             |            | *       |
| 40        | Balance LSB        |             |            | *       |
| 41        |                    |             |            | *       |
| 42        | Pan LSB            |             |            | *       |
| 43        | Expression LSB     |             |            | *       |
| 44        | Effect Cntrl 1 LSB |             |            | *       |
| 45        | Effect Cntrl 2 LSB |             |            | *       |
| 46        |                    |             |            | *       |
| 47        |                    |             |            | *       |
| 48        | Gen Pur Ctrl 1 LSB |             |            | *       |
| 49        | Gen Pur Ctrl 2 LSB |             |            | *       |
| 50        | Gen Pur Ctrl 3 LSB |             |            | *       |
| 51        | Gen Pur Ctrl 4 LSB |             |            | *       |
| 52        |                    |             |            | *       |
| 53        |                    |             |            | *       |
| 54        |                    |             |            | *       |
| 55        |                    |             |            | *       |
| 56        |                    |             |            | *       |
| 57        |                    |             |            | *       |
| 58        |                    |             |            | *       |
| 59        |                    |             |            | *       |
| 60        |                    |             |            | *       |
| 61        |                    |             |            | *       |
| 62        |                    |             |            | *       |
| 63        |                    |             |            | *       |
| 64        | Sustain Pedal      | Yes         | Yes        | *       |
| 65        | Portamento on/off  | No          | No         | *       |
| 66        | Sostenuto          | No          | No         | *       |
| 67        | Soft Pedal         |             |            | *       |
| 68        | Legato Footswitch  |             |            | *       |
| 69        | Hold 2             |             |            | *       |
| 70        | Variation          |             |            | *       |
| 71        | Timbre/Har Inten   | Yes         | Yes        | *       |
| 72        | Release Time       | Yes         |            | *       |
| 73        | Attack Time        | Yes         |            | *       |
| 74        | Brightness         | Yes         |            | *       |

MIDI

| Control # | Function           | Transmitted | Recognized | Remarks               |
|-----------|--------------------|-------------|------------|-----------------------|
| 75        | Sound Cntrlr 6 ↔   | Yes         | Yes        | * <i>Decay</i>        |
| 76        | Sound Cntrlr 7     |             |            | *                     |
| 77        | Sound Cntrlr 8 ↔   | Yes         | Yes        | * <i>Vel-&gt;Filt</i> |
| 78        | Sound Cntrlr 9 ↔   | Yes         | Yes        | * <i>Vel-&gt;amp</i>  |
| 79        | Sound Cntrlr 10    | Yes         | Yes        | ↳ <i>See note</i>     |
| 80        | Gen Purp Cntrlr 5  |             |            | *                     |
| 81        | Gen Purp Cntrlr 6  |             |            | *                     |
| 82        | Gen Pur Cntrlr 7 ↔ |             |            | *                     |
| 83        | Gen Pur Cntrlr 8 ↔ | Yes         | Yes        | *                     |
| 84        | Portamento Cntrl   |             |            | *                     |
| 85        | ↔                  | Yes         | Yes        | * <i>Sustain</i>      |
| 86        |                    |             |            | *                     |
| 87        |                    |             |            | *                     |
| 88        |                    |             |            | *                     |
| 89        |                    |             |            | *                     |
| 90        |                    |             |            | *                     |
| 91        | Effects 1 Depth    | Yes         |            | *                     |
| 92        | Effects 2 Depth    |             |            | *                     |
| 93        | Effects 3 Depth    | Yes         |            | *                     |
| 94        | Effects 4 Depth    |             |            | *                     |
| 95        | Effects 5 Depth    |             |            | *                     |
| 96        | Data Increment     |             |            |                       |
| 97        | Data Decrement     |             |            |                       |
| 98        | NRPN (LSB)         |             |            |                       |
| 99        | NRPN (MSB)         |             |            |                       |
| 100       | RPN (LSB)          |             |            |                       |
| 101       | RPN (MSB)          |             |            |                       |
| 102       |                    |             |            |                       |
| 103       |                    |             |            |                       |
| 104       |                    |             |            |                       |
| 105       |                    |             |            |                       |
| 106       |                    |             |            |                       |
| 107       |                    |             |            |                       |
| 108       |                    |             |            |                       |
| 109       |                    |             |            |                       |
| 110       |                    |             |            |                       |
| 111       |                    |             |            |                       |
| 112       |                    |             |            |                       |



MIDI

| Control #   | Function           | Transmitted | Recognized | Remarks      |
|---|--------------------|-------------|------------|--------------|
| 113   |                    |             |            |              |
| 114   |                    |             |            |              |
| 115   |                    |             |            |              |
| 116   |                    |             |            |              |
| 117   |                    |             |            |              |
| 118   |                    |             |            |              |
| 119   |                    |             |            |              |
| 120   | All Sound Off      | No          | Yes        | ↻ See note   |
| 121   | Reset All Contrls  | No          | Yes        |              |
| 122   | Local Cntrl on/off | No          | No         |              |
| 123   | All Notes Off      | No          | Yes        |              |
| 124   | Omni Mode Off      | No          | Yes ★      | ★ if enabled |
| 125   | Omni Mode On       | No          | Yes ★      | ★ if enabled |
| 126   | Poly Mode Off      | No          | Yes ★      | ★ if enabled |
| 127   | Poly Mode On       | No          | Yes ★      | ★ if enabled |
| <p><b>NOTES:</b> * Vintage Pro can transmit and receive ANY continuous controller number from 1 to 95. Because of Vintage Pro's powerful synth engine, many of the standard MIDI controllers can be user programmed to provide the desired function. A "Yes" response in this chart means that a controller is programmed by default in Vintage Pro.</p> <p>↵ Controller 79 is hard-coded to the Mix Output parameter.<br/>0=Use Preset, 1=Send 1, 2=Send 2, 3=Send 3, 4=Send 4</p> <p>↻ Value of 0 = reset all except vol &amp; pan; value of 127 = reset all</p> <p>Other: Pan: -64 = hard left, +63 = hard right</p> |                    |             |            |              |

## MIDI

**Product ID for Vintage Pro = 0F (15)**

**MIDI Device Inquiry Responses****Family**

MSB 0x04 (Musical Instruments)

LSB 0x04 (ROM Players)

**Members**

MSB 0x00 (Proteus 2000 series)

LSB 0x02 Audity 2000

0x03 Proteus 2000

0x04 B-3

0x05 XL-1

0x06 Virtuoso 2000

0x07 Mo'Phatt

0x08 B-3 Turbo

0x09 XL-1 Turbo

0x0A Mo'Phatt Turbo

0x0B Planet Earth

0x0C Planet Earth Turbo

0x0D XL-7

0x0E MP-7

0x0F Proteus 2500

0x10 Orbit 3

0x11 PK-6

0x12 XK-6

0x13 MK-6

0x14 Halo

0x15 Proteus 1000

0x16 Vintage Pro

There is only one edit buffer which is used by the current preset (the preset shown in the display). You can edit only one preset at a time via SysEx commands, although these presets can be edited independently of the current preset edited using the Front Panel. Remote Preset selection is independent of the edit buffer. Changing the current preset erases the edit buffer.

*Received Channel  
Commands*

Channels number (n) = 0-15. Message bytes are represented in hex. All other numbers are decimal. Running Status is supported.

| <b>Command</b>           | <b>Message</b> | <b>Comments</b>                 |
|--------------------------|----------------|---------------------------------|
| Note Off                 | 8n kk vv       |                                 |
| Note On                  | 9n kk vv       | velocity 0 = note off           |
| Program Change           | Cn vv          | 0-127                           |
| Channel Aftertouch       | Dn vv          | 0-127                           |
| Pitch Bend               | En ll mm       | l = lsb, m = msb                |
| Real-time Controller     | Bn cc vv       | cc = 00-31, 64-95               |
| Footswitch               | Bn cc vv       | cc = 64-79, vv ≥ 64 = on        |
| Volume                   | Bn 07 vv       | 0-127                           |
| Pan                      | Bn 0A vv       | 0=left, 127=right, 64=center    |
| All Sound Off            | Bn 78 00       | turns all sound off             |
| Reset All Controllers    | Bn 79 00       | ignored in omni mode            |
| All Notes Off            | Bn 7B 00       | ignored in omni mode            |
| Omni Mode Off*           | Bn 7C 00       | forces all notes & controls off |
| Omni Mode On*            | Bn 7D 00       | forces all notes & controls off |
| Mono Mode On (Poly Off)* | Bn 7E 00       | forces all notes & controls off |
| Poly Mode On (Mono Off)* | Bn 7F 00       | forces all notes & controls off |
| Bank Select MSB          | Bn 00 bb       | bb = bank MSB (see page 110)    |
| Bank Select LSB          | Bn 20 bb       | bb = bank LSB (see page 110)    |

**\* Special Notes:**

- **From Omni Mode** .....Omni Off turns Poly On.
- **From Poly Mode** .....Omni On turns Omni On; Mono On turns Mono On.
- **From Mono Mode** .....Mono Off turns Poly On; Omni On turns Omni On.
- **From Multi Mode** .....Omni On turns Omni On; Omni Off or Mono Off turns Poly On; Mono On turns Mono On.
- All other changes have no effect.

*SysEx Specification*

Vintage Pro contains an extensive set of MIDI SysEx commands. (*Virtually every parameter is controllable via SysEx.*) Because of the size and technical nature of the System Exclusive specification, it is beyond the scope of this manual.

# Technical Specifications

|                              |  |
|------------------------------|--|
| <b>Audio Channels:</b>       | 128  |
| <b>MIDI:</b>                 | 2 MIDI In, 2 MIDI Out, 2 MIDI Thru   |
| <b>MIDI Channels:</b>        | 32 (2 MIDI in ports)   |
| <b>Presets:</b>              | 512 user presets. <i>(The number of ROM presets is determined by the sound SIMMs installed.)</i> |
| <b>Filters:</b>              | 2nd order to 12th order filters<br>(50 different types)  |
| <b>Audio Outputs:</b>        | 6 polyphonic analog outputs  |
| <b>Submix Inputs:</b>        | 4 analog inputs (sum to main outs)   |
| <b>Digital Output:</b>       | S/PDIF stereo (AES-pro compatible)   |
| <b>Max. Output Level:</b>    | +4 dB  |
| <b>Output Impedance:</b>     | 1000 Ohms  |
| <b>Sound Memory:</b>         | 32 MB (expandable to 128 MB)   |
| <b>Data Encoding:</b>        | 16-bit linear data, 24-bit $\Delta\Sigma$ DACs   |
| <b>Effects Engine:</b>       | 24-bit internal processing   |
| <b>Sample Playback Rate:</b> | 44.1 kHz   |
| <b>Signal to Noise:</b>      | >92 dB   |
| <b>Dynamic Range:</b>        | >90 dB   |
| <b>Frequency Response:</b>   | 20 Hz - 20 kHz (+2/-1 dB)  |
| <b>THD + Noise:</b>          | < 0.02% (1kHz sine wave, A-weighting)  |
| <b>IMD</b>                   | < 0.05%  |
| <b>Stereo Phase</b>          | Phase Coherent +/- 1° at 1 kHz   |
| <b>Power Consumption:</b>    | 15 Watts   |
| <b>Voltage Input:</b>        | 90VAC-260VAC at 50Hz-60Hz  |
| <b>Dimensions</b>            | H: 1.75 inches<br>W: 19 inches<br>L: 8.5 inches  |
| <b>Weight</b>                | 6 lb., 14 oz. (3.1 Kg)   |

## Warranty

### **Please read this warranty, as it gives you specific legal rights.**

#### *Limited Warranty*

This product is warranted, to the original consumer purchaser, to be free of all defects in workmanship and materials for a period of one (1) year (warranty period is two (2) years in the European Union, effective Jan-1-2002), from the date of such purchase from an authorized E-MU Systems dealer, provided that: (a) the Warranty Registration Card is filled out and returned to E-MU Systems within 14 days of the purchase date; (b) the E-MU Systems service center is provided a copy of the consumer purchaser's sales receipt; and (c) E-MU Systems has confirmed the validity of the subject unit's serial number.

#### *Warranty Restrictions*

Specifically, but without limitation, E-MU Systems does not provide warranty service for:

- Damages due to improper or inadequate maintenance, accident, abuse, misuse, alteration, unauthorized repairs, tampering, or failure to follow normal operating procedures as outlined in the owner's manual;
- Deterioration or damage of the cabinet;
- Damages occurring during any shipment of the unit;
- Any unit which has been modified by anyone other than E-MU Systems.
- Any unit with an invalid or wholly or partially obliterated serial number.

NO OTHER EXPRESS OR IMPLIED WARRANTY IS MADE, AND E-MU SYSTEMS SPECIFICALLY DISCLAIMS ANY IMPLIED WARRANTY OF MERCHANTABILITY, SATISFACTORY QUALITY, AND FITNESS FOR A PARTICULAR PURPOSE. E-MU SYSTEMS'S LIABILITY UNDER WARRANTY IS LIMITED TO REPAIR OR REPLACEMENT OF THE UNIT, OR REFUND, AT EMU'S OPTION. IN NO EVENT WILL E-MU SYSTEMS BE LIABLE FOR LOSS OF REVENUE OR SAVINGS, LOSS OF TIME, INTERRUPTION OF USE, OR ANY OTHER CONSEQUENTIAL, INDIRECT, INCIDENTAL, SPECIAL OR EXEMPLARY DAMAGES.

The foregoing will apply notwithstanding the failure of essential purpose of any remedy provided herein. Some jurisdictions do not allow the exclusion of implied warranties or conditions, or limitations on how long an implied warranty or condition may last, so the above limitations may not apply. This warranty gives you specific legal rights. You may have other rights which vary from jurisdiction to jurisdiction.

## *How To Obtain Warranty Service*

All E-MU Systems products are manufactured with the highest standards of quality. If you find that your unit does require service, it may be done by any authorized E-MU Systems service center. If you are unable to locate a service center in your area, please contact EMU's Service Department at (831) 438-1921. They will either refer you to an authorized service center in your area or ask that you return your unit to the E-MU Systems factory.

When returning your unit to the E-MU Systems factory, you will be issued a Return Merchandise Authorization (RMA) number. Please label all cartons, shipping documents and correspondence with this number. E-MU Systems suggests you carefully and securely pack your unit for return to the factory. (Do not send the power cord or operation manual.) Send the unit to E-MU Systems, Inc., 1600 Green Hills Road, Scotts Valley, CA 95066. You must pre-pay shipping charges to E-MU Systems. E-MU Systems will pay return shipping charges. You will be responsible for any damage or loss sustained during shipment in any direction.

3/99

# Index

## Symbols

- “+” modulation polarity 144
- “±” modulation polarity 144

## Numerics

- 19-tone tuning 154
- 1-bar trigger 40
- 2-pole filters 104
- 4-pole filters 104
- 6-pole filters 104

## A

- A effect types 175, 176
- absolute value processor 93
- AES pro output format 82
- aftertouch, mono 85
- algorithm
  - FXA 177, 178
  - FXB 177, 179
  - master FXA 70
  - master FXB 71
- all layers 113, 115
- alternate tuning 154
- amount
  - patchcord 108, 143
- amplifier 126
- amplitude 132, 162
- amplitude envelope 127
- amplitude modulation 84
- arpeggiate multiple channels 61
- arpeggiator 28
  - controllers 48
  - copy pattern 191
  - copy settings 190
  - copying settings 191
  - delay 53, 54
  - extension 48
  - extension count 52
  - extension interval 52
  - factory patterns 50
  - gate 48
    - time 51
  - interval 48
  - key offset 58
  - key range 56
  - keyboard thru 55

- latch mode 55
- master parameters 48
- MIDI out 46
- MIDI song start 46
- modes 31, 47, 49
- note value 50, 54
- patchcord destinations 152
- pattern 47, 50
  - speed 50
- resolution 48
- status 49
- user patterns 57
- velocity 48, 51
- assign group 131
- attack, envelope 128, 138, 145, 166
- audition
  - beats 36
  - button 18, 22
  - preset 18
  - riff 157
- auxiliary envelope 87, 138

## B

- B effect types 175, 176
- balance 107
- band-pass filter 103, 133
- bandwidth 105
- bank number 20, 26
- bank organization 20
- bank select display 22
- banks, selecting 26
- base tempo 33
- basic channel 36
- basic setup 14
- basics, programming 83
- beats 36
  - busy 39
  - channel 36
  - keys layout 40
  - keys offset 41
  - part group 44
  - part transpose 43
  - part velocity 42
  - patchcord destinations 152
  - riffs 31, 34
  - variation 40
  - velocity group 1-4 38
  - xpose group 1-4 38
- bend range 64
- breath controller 76
- bts busy 39
- button
  - control 21
  - cursor 22
  - edit menu 21
  - home/enter 63
  - master menu 21
  - mix screen 68

- save/copy 22
- bypass effects 180
- bypassed, effects mode 180

**C**

- calibration 79
- category
  - preset 200
- center frequency 105
- changing
  - filter type 166
  - MIDI preset 75
  - preset 20
  - the voice 159
- channel
  - MIDI enable 74
  - MIDI select 26
  - pan 27
  - selection, MIDI 26
  - volume 27
- chorus 175, 185
  - width 161
- chorusing 129, 161
- clear beats part 34, 35
- clock
  - divisor 85
  - MIDI 33
  - modulation 91
  - using external MIDI 33
- coarse tuning 126, 160
- comb filter 134, 176
- comb filter, effect 185
- connection instructions 14
- continuous controllers 108
- contour, envelope 85, 128
- control
  - button 21
  - data entry 23
  - effects multi mode 69
  - keys 35
  - mode 21
  - rows 21
  - volume 21
- controller
  - assigning real-time 75
  - footswitch 76
  - knobs 23, 25, 75, 109
  - MIDI 75, 108
  - MIDI #10 27
  - MIDI #7 27, 108
  - MIDI real-time 108
  - modes 23
  - quick edit and real-time mode 24
  - real-time 21, 23
    - knobs 23
    - only mode 23

- standardized MIDI numbers 76

copying

- layers 188
- patchcords 189
- preset banks 191
- preset patchcords 190
- presets 188

create random preset 195

crossfade

- between effects 151
- random 86
- ranges 122

current tempo

- offset 157

cursor buttons 22

curve

- glide 132
- velocity 65
- volume 161

cutoff frequency 103, 163

**D**

- damping, high frequency 176, 184
- data entry control 23
- DC offset, example 100
- DCA 107, 168
- decay
  - effect A 70, 176
  - effects 176
  - envelope 161
- deep edit mode 78
- default assignment, beats 35
- delay 129
  - arpeggiator 53, 54
  - effect B 72
  - effect processor 186
  - effects 175, 176
  - LFO 141
  - master FXB 72
  - preset link 156
- demo sequences 18
- descending arpeggiator 47
- destinations, modulation 92, 145
- device ID 73
- device, external MIDI 90
- digital output format 82
- dimensions 226
- diode processor 94
- display, viewing angle 82
- distortion, effect processor 186
- double & detune 129, 161
- doubling 185
- dual channel beats 36
- dual tap, delay 186
- duration, arp pattern 59
- dynamic filters 101
- dynamic range 226



**E**

- edit menu button 21
- editing
  - arp user patterns 57
- editing, presets 159
- effects
  - A type 175
  - B into effect A 182
  - B submix routing 72
  - B type 175
- busses 173
- by channel number 182
- bypass 180
- channel number setup 182
- chorus 185
- decay 176
- delay 176, 186
- description 184
- diagram 147, 148, 150
- distortion 186
- doubling 185
- dual tap delay 186
- feedback 176, 186
- flanger 185
- FXA decay 70
- FXA HF Damping 70
- FXB feedback 72
- FXB->FXA 70, 177
- global 181
- HF damping 176
- LFO rate 72, 176
- master 173, 178, 181
  - A algorithm 70
  - B algorithm 71
  - FxB>FxA 178
  - LFO rate 72
- mode 68, 180
- multi mode control 69, 180
- panning delay 186
- patchcords 151
- preset 147, 177
- processor 173
- programmed in the preset 147, 177
- returns 17
- reverb 184
- routing diagram 67
- send amounts 173
- sends 66, 173
- slapback 185
- stereo delay 186
- submix routing, A 71, 150, 151
- type A 70, 149, 175, 176
- type B 71, 150, 175, 176
- vibrato 186

- enabling MIDI channels 74
- enter button 23
- envelope
  - attack 128, 138, 145
  - auxiliary 138

- decay 161
- filter 136, 164, 165, 167
- generator 85, 87
  - example 104
- mode, factory 162
- mode, filter 165
- release 161
- repeating 88
- reverberation 184
- volume 127, 128, 161, 162

- equal temperament tuning 154
- errors, data transmission 80
- extension
  - count, arpeggiator 52
  - interval, arpeggiator 52
- external clock, MIDI 33
- external processing 170

**F**

- factory
  - envelope mode 162
  - patterns, arpeggiator 50
- Fc 136, 163
- feedback 176
  - effect 186
  - FXB 72
- fills, beats 34
- filter
  - 2-pole 104
  - 4-pole 104
  - 6-pole 104
  - bandpass 103, 133
  - changing type 166
  - comb 134, 176
  - definition 102
  - dynamic 101
  - envelope 87, 136, 164, 165
  - envelope attack 166
  - envelope generator 136, 167
  - envelope mode 165
  - frequency 136, 145, 163
  - high-pass 102, 163
  - low-pass 102
  - mode 165
  - morph 106
  - notch 103
  - overview 163
  - parametric 105
  - pole 104
  - Q 136, 163, 164
  - swept EQ 105
  - troubleshooting 168
  - tutorial 101
  - type 163, 166
  - type, changing 166
  - Z-plane 106, 107, 132
- fine tuning 126, 160
- fingered glide solo mode 131

first key 96  
 flange effects 175  
 flanger, effect processor 185  
 flip-flop processor 94  
 footswitch 76, 85  
 format, output 82  
 free running, LFO 140  
 frequency  
   center 105  
   cutoff 103  
   filter 136, 145  
 frequency modulation 84  
 front panel knobs 199  
 FX cords 151  
 FX mode 68, 180  
 FXA algorithm 177, 178  
 FXA parameters 150  
 FXB -> FXA 177, 178, 182  
 FXB algorithm 71, 150, 177, 179  
 FXB parameters 151  
 FXB submix routing 72

**G**

gain processor 94  
 gamelan tuning 154  
 gate 85  
   time 51  
 generator  
   envelope 85  
   filter envelope 136, 167  
   noise and random 85  
   volume envelope 127  
 glide 132  
   curve 132  
   key 85  
   rate 85, 132  
 global effects 178, 181  
 grooves, beat 34  
 group, assigning channels to a 131  
 group, beats 34

**H**

headphones 14  
 HF damping 70  
 high frequency damping 176, 184  
 high-pass filter 102, 163  
 home 23  
 home position 20  
 home/enter button 63

**I**

ID number  
   sysex 73  
 implementation chart, MIDI 218, 220  
 initial pan position 126

initial volume 126  
 instrument 107, 159  
   category 29  
   listing 205  
   selecting 116  
 inverting LFO waves 90

**J**

just C tuning 154  
   description 155  
 just intonation 154

**K**

key  
   glide 85  
   layout, beats 40  
   offset, arpeggiator 58  
   range 118  
     arpeggiator 56  
     preset link 156  
   sync, arpeggiator 53  
   transpose 125  
   trigger 40  
   tuning 81  
   velocity 85  
 keyboard  
   beats trigger layouts 34  
   character assignments 114  
   key 85  
   layering & splitting 169  
   pressure 85  
   range 117, 118  
   splitting 169  
   thru, arpeggiator 55  
   transpose 125  
   transpose on/off 130  
   tuning 154  
     19-tone 154  
     equal temperament 154  
     gamelan 154  
     just C 154  
     Kirnberger 154  
     repeating octave 154  
     Scarlatti 154  
     Vallotti 154  
     Werkmeister III 154  
 Kirnberger tuning 154  
 knob  
   calibration 79  
   controller 25, 109  
   MIDI out 78  
   preset quick edit 77  
   transmit MIDI 24  
   typical functions 199  
 knobs MIDI out 78

**L**

- lag amount 95
- lag processor 93
- latch
  - beats part 40
  - keys in beats 34
  - mode, arpeggiator 55
- layer
  - copying a 188
  - definition 115
  - instrument 83
  - selecting 115
- layering presets 169
- legato 130
- LFO 138
  - effect B 72
  - flanger 186
  - key sync 140
  - master FXB rate 72
  - rate 176
  - rate, effect 72
  - tricks & tips 139
  - trigger 90
  - variation 142
  - waveforms 89, 139
- linking presets 156, 157, 169
- looping envelopes 88
- low frequency oscillator 85, 89, 138
  - delay 141
  - free running 140
  - sync 138, 140
  - variation 142
- low-pass filter 102
  - example 104

**M**

- main screen 26, 63
- master
  - arpeggiator
    - parameters 48
  - bend range 64
  - clock
    - current tempo 33
    - modulation 90
  - effects 173, 178, 181
  - FXA algorithm 70
  - FXB algorithm 71
  - menu 63
  - menu button 21
  - riff 36, 44
  - tempo 77
    - offset 157
  - tuning 64
- melody solo mode
  - (high) 130
  - (last) 130
  - (low) 130

## menu

- arp/beats/multi 31
- edit 113
- effects 173
- master 63
- save/copy 187

MIDI 76

- A-L messages 24
- bank select display 18, 22
- channel selection 26
- clock 33
- continuous controllers 75, 85, 108
- controller #7 27
- device ID 73
- enable 74
- external clock 33, 90
- footswitches 76
- implementation chart 218, 220
- in 14
- inputs A & B 15, 16
- knobs transmit 24, 78
- mode 30, 73, 173
- multi mode 73
- omni mode 73
- out 15
- out, arp/beats 46
- pan control #10 27
- poly mode 73
- port A & B 30
- real-time controllers 108
- receive program change 75
- received channel commands 225
- receiving sysex data 81
- recording sysex data 81
- send sysex data 81
- song start 46
- standardized controller numbers 76
- sysex data, sending 80
- sysex packet delay 80
- thru 16
- transmit, knob 78

minimoog, solo mode 131

- mix output 66, 146, 174
- mix view screen 68
- mod wheel 85

mode

- arpeggiator 49
  - latch 55
- control 21
- controller 23
- deep edit 78
- effect bypass 180
- effects 68, 180
- factory 162
- filter envelope 165
- MIDI 73, 173
- mono 225
- multi 73, 173, 225
- non-transpose 130
- omni 73, 180, 225

## Index

### N

- poly 73, 180, 225
- quick edit & real-time controller 24
- real-time controllers only 23
- solo 130
- time-based 165
- modulation
  - amplitude 84
  - clock 91
  - definition 84
  - destinations 92
  - note-on 92
  - polarity 144
  - processors 93, 97
  - random 86
  - routing 143
  - sources 85, 86
  - sources & destinations 145
  - wheel 76
- mono
  - aftertouch 85
  - A-I, assign group 131
  - mode 225
- morph filter 106
- multi mode 73, 173, 225
  - control, effects 180
  - effects control 69
- multichannel volume/pan control 68
- multimode map
  - send/receive 80
- multiple arpeggiators 61
- multiple trigger solo mode 130
- multisetup 22, 34
  - restore 192
  - saving 193
  - send/receive 80
- multitimbral 30
  - sequencing 171
- mute beats 34, 35

### N

- Name
  - multisetup 193
- naming
  - preset 114
  - user arp pattern 60
- noise & random generators 85
- non-transpose mode 130
- notch filter 103
- note value
  - arpeggiator 50, 54
- note-on modulation 92

### O

- offset, arpeggiator key 58
- omni mode 73, 180, 225
- output
  - format 82

- headphones 14
- jack 14, 15, 16, 17
- mix 66, 146, 174
- mono 14
- routing 146
- stereo 111
- overall tuning, adjusting 64

### P

- packet delay, MIDI sysex 80
- pan 107
  - channel 27
  - control 27
  - initial 126
  - preset link 156
  - view screen 68
- panning delay, effect 186
- panning L/R 27
- parameters
  - effects 175
- parametric filters 105
- part
  - beat 22
- part, beat 34
- patchcord 86, 143
  - amount 108, 143
  - copying a 189
  - example 97
  - routing 92
- pattern
  - arpeggiator 47, 50
    - naming 60
    - speed 50
    - user 57
- pedal 85
- performance controllers 85
- performance setup 16
- pink noise, example 99
- pitch wheel 85, 167
  - master bend range 64
  - pitch bend range 146
- pitch, shifting 160
- play solo layers 157
- polarity
  - modulation & LFO 144
  - ramp rate 96
- pole filters 104
- poly all, assign group 131
- poly mode 73, 180, 225
- poly, assign group 131
- portamento 132
- power 17
- power consumption 226
- preset
  - architecture 115
  - audition 18, 22
  - category 20, 29
  - changing 20

- copying 188
- editing 159
- effects 147, 177
- links 156, 157, 169
- listing 201
- MIDI changes 75
- naming 114
- patchcords 151
- quick edit 77
- random 194
- selecting 19, 26
- user 81
- preset lag 95
- preset ramp 95
- processor
  - 4x gain 94
  - absolute value 93
  - diode 94
  - effect 173
  - flip-flop 94
  - modulation 97
  - quantizer 94
  - summing amp 93
  - switch 93
- product description 1
- program change, receive 75
- program/preset map
  - send/receive 80
- program->preset map 74
- programming basics 83

## Q

- Q 103, 134, 135, 136, 163, 164, 166
- quantized, arp sync 53
- quantizer 94, 100
  - example 99
- quick edit
  - and real-time controllers mode 24
  - preset 77

## R

- ramp rate 96
- random
  - creating presets 194
  - crossfade 86
  - crossswitch 123
  - generator, noise and 85
  - modulation sources 86
- range
  - arp extension count 52
  - key 117, 118
  - keyboard 117
  - pitchbend 146
  - velocity 120
- rate
  - effect LFO 72, 176
  - glide 132

- LFO 140
  - master FXB LFO 72
- rate/level envelopes 87
- realtime control of arps 48
- real-time controller 21, 23, 108
  - assignment 75
  - crossfading 122
  - knobs 23
  - mode, quick edit and 24
- real-time crossfade 122
- receive program change 75
- receiving MIDI SysEx data 81
- recording MIDI SysEx data 81
- rectifier 93
- release velocity 85
- release, envelope 161
- rename, arpeggiator pattern 60
- repeat
  - arpeggiator pattern 59
- resonance 103, 134, 135, 136, 164, 166
- restore
  - multisetup 192
  - multisetup via MIDI 192
- reverb 175, 184
  - generalized envelope 184
- riff
  - assignment 157
  - controllers 45
  - listing 209, 210, 211
  - MIDI out 78
  - playing 18, 22
  - tempo 45
- ROM card identifier 19
- routing
  - FXA submix 71, 150, 151
  - FXB submix 72
  - modulation 143
  - output 146

## S

- S/PDIF 14
  - output format 82
- safety instructions 4
- Save
  - multisetup 193
- save
  - arp parameters 32
  - preset 187
- save/copy button 22
- save/copy menu 187
- Scarlatti tuning 154
- screen
  - main 26, 63
  - preset select 26
  - viewing angle 82
- selecting a MIDI channel 26
- selecting presets 19, 26

- send
    - amount 173
      - FXA 71, 150
      - FXB 72, 151
    - effect 66
    - preset effect 146
  - sequence
    - using multisetups in a 187
  - sequencing 171
  - setup
    - basic 14
    - performance 16
    - studio 15
  - sicherheitsvorschriften 7
  - signal path 107, 173
  - slapback, effect 185
  - solo
    - layer 157
    - mode 130
  - sound navigator 29
    - selecting instruments 116
  - sound start 129
  - sources, modulation 145
  - specifications, technical 226
  - split keyboard 156, 169
    - using links 169
  - stack
    - layers 119
    - presets 156
  - standard MIDI controller numbers 76, 220
  - standard MIDI switch number 76
  - start/stop beats 34, 35
  - step-by-step instructions 159
  - stereo delay, effect 186
  - stereo outputs 111
  - stolen voices 131
  - studio setup 15
  - sub output jacks 17
  - submix in/out 170
  - submix jack routing 146
  - summing amp 93, 94
  - summing nodes 84
  - swept EQ filter 105
  - switch processor 93, 97
  - sync
    - arp key 53
    - LFO 138, 140
    - MIDI song start 46
  - synth solo mode
    - (high) 131
    - (last) 130
    - (low) 131
  - system exclusive
    - device ID 73
    - ID 73
    - packet delay 80
    - send arp data 56
    - send data 81
- T**
- technical specifications 226
  - tempo offset 157
  - tempo-based 127, 162
  - tempo-based envelope 88, 136
  - time
    - arpeggiator gate 51
  - time, master FXB delay 72
  - time-based 127, 162, 165
    - envelope 87, 136
  - transmission errors 80
  - transmit MIDI, knob 78
  - transpose 64, 125, 126
    - arpeggiator 52
    - beat part 43
    - preset link 156
  - trig hold, beats 35
  - trigger channel 36
  - trigger key 22, 34
  - troubleshooting, filter 168
  - tune 64
  - tuning 126, 160
    - 19-tone 154
    - coarse 160
    - equal temperment 154
    - fine 160
    - gamelan 154
    - just C 154
    - key 81
    - keyboard 154
    - Kirnberger 154
    - repeating octave 154
    - Scarlatti 154
    - Vallotti 154
    - Werkmeister III 154
  - tuning tables
    - send/receive 80
  - tutorial, filter 101
  - tutorial, programming 159
- U**
- unlatch beats part 40
  - user key tuning 81
  - user pattern, arpeggiator 57
    - repeat 59
    - velocity 59
  - user presets 81
- V**
- Vallotti tuning 154
  - variation
    - beats 40
    - LFO 142
  - velocity
    - arpeggiator 51
    - crossfade 120
    - curve 65, 211

- key 85
- preset link 156
- release 85
- user pattern 59
- vibrato, effect processor 186
- viewing angle, screen 82
- voices
  - changing 159
  - stolen 131
- voltage setting 17
- volume
  - channel 27
  - control 21
  - control #7 27
  - curve 161
  - envelope 87, 107, 127, 128, 161, 162
  - initial 126
  - preset link 156

**W**

- waveforms
  - instruments 205
  - inverting 90
  - LFO 89
- weight 226
- Werkmeister tuning 154
- wheel
  - modulation 76, 85
  - pitch 85, 167
- width, chorus 161

**Z**

- Z-plane filter 106, 107, 132

***Notes***

---